

**C2, ARMY FM 10-500-71
AIR FORCE TO 13C7-6-141**

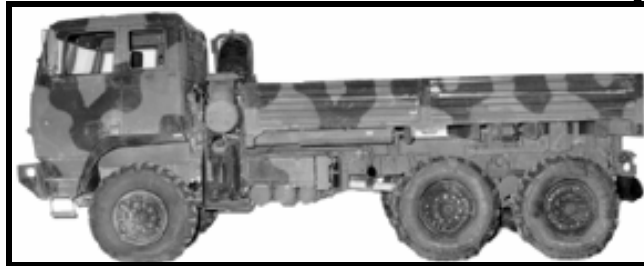

AIRDROP OF SUPPLIES AND EQUIPMENT:

**RIGGING THE
FAMILY OF MEDIUM
TACTICAL VEHICLES (FMTV)**



DECEMBER 2003

DISTRIBUTION RESTRICTION: Approved for public release; distribution is unlimited.

**HEADQUARTERS
DEPARTMENT OF THE ARMY
DEPARTMENT OF THE AIR FORCE**

**This publication is available at Army
Knowledge Online (www.us.army.mil)
and the General Dennis J. Reimer
Training and Doctrine Digital Library at
(www.adtdl.army.mil)**

CHANGE
NO. 2

HEADQUARTERS
DEPARTMENT OF THE ARMY AND
DEPARTMENT OF THE AIR FORCE
Washington, DC, 9 December 2003

AIRDROP OF SUPPLIES AND EQUIPMENT:
RIGGING THE FAMILY OF MEDIUM TACTICAL VEHICLES (FMTV)

This change adds the procedures to the basic manual for rigging the M1094, 5-ton dump truck and adds the procedures for rigging the M1095, 5-ton trailer on a type V platform for low-velocity airdrop.

FM 10-500-71/TO 13C7-6-141, 1 December 1999, is changed as follows:

1. New or changed material is identified by a vertical bar (█) in the margin opposite the changed material.
2. File this transmittal sheet in front of the publication for reference purpose.
3. Remove old page and insert new page as indicated below:

Remove old pages:

Cover

i through iii

1-1

4-1 through 4-79

Glossary

Reference

Insert new pages:

Cover

i through iv

1-1

4-1 through 4-76

5-1 through 5-101

Appendix-1 and Appendix-2

Glossary-1 and Glossary-2

Reference-1 through Reference-3

DISTRIBUTION RESTRICTION: Approved for public release; distribution is unlimited.

**C2, FM 10-500-71
/TO 13C7-6-141
9 December 2003**

By Order of the Secretary of the Army and the Air Force:

PETER J. SCHOOMAKER
*General, United States Army
Chief of Staff*

Official:

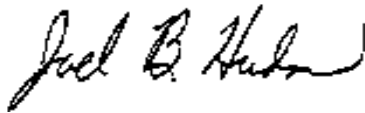

JOEL B. HUDSON
*Administrative Assistant to the
Secretary of the Army*
0334201

LESTER L. LYLES
General, USAF
Commander, AFMC

JOHN P. JUMPER
General, USAF
Chief of Staff

DISTRIBUTION:

Active Army, Army National Guard, and U.S. Army Reserve: To be distributed in accordance with the initial distribution number 115485, requirements for FM 10-500-71.

CHANGE NO. 1

**HEADQUARTERS
DEPARTMENT OF THE ARMY
DEPARTMENT OF THE AIRFORCE
WASHINGTON, DC, 1 July 2001**

**AIRDROP OF SUPPLIES AND EQUIPMENT:
RIGGING THE FAMILY OF MEDIUM TACTICAL VEHICLES (FMTV)**

This change adds the procedures for rigging the M1094, 5-ton dump truck on a type V platform for low-velocity airdrop. It also changes honeycomb stack four, used with the M1093, 5-ton cargo truck.

FM 10-500-71/TO 13C7-6-141, 1 December 1999, is changed as follows:

1. New or changed material is identified by a vertical bar (■) in the margin opposite the changed material.
2. File this transmittal sheet in front of the publication for reference purpose.
3. Remove old page and insert new page as indicated below:

Remove old pages:

i and ii

1-1

3-19 and 3-20

Insert new pages:

i through iii

1-1

3-19 and 3-20

4-1 through 4-81

DISTRIBUTION RESTRICTION: Approved for public release; distribution is unlimited.

C1, FM 10-500-71/TO 13C7-6-141
1 July 2001

By Order of the Secretary of the Army and the Air Force:

ERIC K. SHINSEKI
General, United States Army
Chief of Staff

Official:

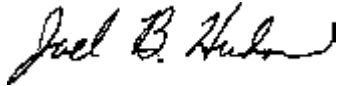

JOEL B. HUDSON
Administrative Assistant to the
Secretary of the Army
0112701

GEORGE T. BABBITT
General, USAF
Commander, AFMC

MICHAEL E. RYAN
General, USAF
Chief of Staff

DISTRIBUTION:

Active Army, Army National Guard, and U.S. Army Reserve: To be distributed in accordance with the initial distribution number 115485, requirements for FM 10-500-71.

This Publication is available on the
General Dennis J. Reimer Training
And Doctrine Digital Library at
www.adtdl.army.mil

**FIELD MANUAL
NO. 10-500-71
TECHNICAL ORDER
NO. 13C7-6-141**

**HEADQUARTERS
DEPARTMENT OF THE ARMY
DEPARTMENT OF THE AIR FORCE
Washington, DC, 9 December 2003**

**AIRDROP OF SUPPLIES AND EQUIPMENT:
RIGGING THE FAMILY OF MEDIUM TACTICAL VEHICLES (FMTV)**

TABLE OF CONTENTS

CHAPTER 1 INTRODUCTION

	Paragraph	Page
Scope.....	1-1	1-1
Special Considerations.....	1-2	1-1
Recommended Changes.....	1-3	1-1

**CHAPTER 2 RIGGING M1081, 2 1/2-TON CARGO TRUCK ON A 24-FOOT
TYPE V PLATFORM FOR LOW-VELOCITY AIRDROP**

Section I. RIGGING M1081, 2 1/2-TON CARGO TRUCK WITH BASIC LOAD

Description of Load.....	2-1	2-1
Preparing Platform.....	2-2	2-2
Preparing Honeycomb Stacks.....	2-3	2-3
Positioning Honeycomb Stacks.....	2-4	2-15
Preparing Truck.....	2-5	2-17
Stowing Basic Load.....	2-6	2-39
Lifting and Positioning Truck.....	2-7	2-49
Installing Lashings.....	2-8	2-50
Installing and Safetying Suspension Slings.....	2-9	2-54
Building and Positioning the Parachute Stowage Platform.....	2-10	2-55
Stowing Cargo Parachutes.....	2-11	2-57
Installing Extraction System.....	2-12	2-58
Installing Release System.....	2-13	2-60
Installing Provisions for Emergency Restraints.....	2-14	2-61
Placing Extraction Parachute.....	2-15	2-61
Marking the Rigged Load.....	2-16	2-61
Equipment Required.....	2-17	2-61

Section II. RIGGING M1081, 2 1/2-TON CARGO TRUCK WITH ACCOMPANYING LOAD

	Paragraph	Page
Description of Load.....	2-18	2-69
Preparing Platform.....	2-19	2-70
Preparing Honeycomb Stacks.....	2-20	2-71
Positioning Honeycomb Stacks.....	2-21	2-83
Preparing Truck.....	2-22	2-85
Stowing Accompanying Load.....	2-23	2-86
Lifting and Positioning Truck.....	2-24	2-94
Installing Lashings.....	2-25	2-95
Installing and Safetying Suspension Slings.....	2-26	2-99
Building and Positioning the Parachute Stowage Platform.....	2-27	2-100
Stowing Cargo Parachutes.....	2-28	2-102
Installing Extraction System.....	2-29	2-103
Installing Release System.....	2-30	2-105
Installing Provisions for Emergency Restraints.....	2-31	2-106
Placing Extraction Parachute.....	2-32	2-106
Marking the Rigged Load.....	2-33	2-106
Equipment Required.....	2-34	2-106

CHAPTER 3 RIGGING M1093, 5-TON 6 x 6 STANDARD CARGO TRUCK ON A 28-FOOT TYPE V PLATFORM FOR LOW-VELOCITY AIRDROP

Description of Load.....	3-1	3-1
Preparing Platform.....	3-2	3-2
Preparing Honeycomb Stacks.....	3-3	3-3
Positioning Honeycomb Stacks.....	3-4	3-19
Preparing Truck.....	3-5	3-21
Stowing Basic Load.....	3-6	3-43
Lifting and Positioning Truck.....	3-7	3-53
Installing Lashings.....	3-8	3-54
Installing and Safetying Suspension Slings.....	3-9	3-58
Stowing Cargo Parachutes.....	3-10	3-59
Installing Extraction System.....	3-11	3-61
Installing Release System.....	3-12	3-62
Installing Provisions for Emergency Restraints.....	3-13	3-63
Placing Extraction Parachute.....	3-14	3-63
Marking the Rigged Load.....	3-15	3-63
Equipment Required.....	3-16	3-63

CHAPTER 4 RIGGING M1094, 5-TON DUMP TRUCK ON A 28-FOOT TYPE V PLATFORM FOR LOW-VELOCITY AIRDROP

	Paragraph	Page
Description of Load.....	4-1	4-1
Preparing Platform.....	4-2	4-2
Preparing Honeycomb Stacks.....	4-3	4-3
Positioning Honeycomb Stacks.....	4-4	4-23
Preparing Truck.....	4-5	4-25
Stowing Accompanying Load.....	4-6	4-48
Lifting and Positioning Truck.....	4-7	4-55
Installing Lashings.....	4-8	4-57
Installing and Safetying Suspension Slings.....	4-9	4-63
Building and Positioning the Parachute Stowage Platform.....	4-10	4-64
Stowing Cargo Parachutes.....	4-11	4-66
Installing Extraction System.....	4-12	4-67
Installing Release System.....	4-13	4-69
Installing Provisions for Emergency Restraints.....	4-14	4-72
Placing Extraction Parachute.....	4-15	4-72
Marking the Rigged Load.....	4-16	4-72
Equipment Required.....	4-17	4-72

CHAPTER 5 RIGGING THE M1095, 5-TON TRAILER ON A 24-FOOT TYPE V PLATFORM

Description of Load.....	5-1	5-1
Preparing Platform.....	5-2	5-2
Stowing Accompanying Load on Platform.....	5-3	5-3
Preparing Honeycomb Stacks.....	5-4	5-28
Positioning Honeycomb Stacks.....	5-5	5-41
Preparing Trailer.....	5-6	5-43
Stowing Trailer Accompanying Load.....	5-7	5-48
Lifting and Positioning Trailer.....	5-8	5-74
Installing Lashings.....	5-9	5-76
Building Sling Spreader and Installing Suspension Slings.....	5-10	5-85
Safety Tying Suspension Slings.....	5-11	5-90
Building and Positioning the Parachute Stowage Platform.....	5-12	5-91
Stowing Cargo Parachutes.....	5-13	5-93
Installing Extraction System.....	5-14	5-94
Installing Release System.....	5-15	5-96
Installing Provisions for Emergency Restraints.....	5-16	5-97
Placing Extraction Parachute.....	5-17	5-97
Marking the Rigged Load.....	5-18	5-97
Equipment Required.....	5-19	5-97

APPENDIX.....Appendix-1

GLOSSARY.....Glossary-1

REFERENCES.....References-1

CHAPTER 1

INTRODUCTION

1-1. Scope

This manual tells and shows how to prepare and rig the following series of light and medium tactical vehicles for low-velocity airdrop from a C-130, C-141, C-17, and C-5 aircraft:

- a. M1081, 2 1/2-ton cargo truck.
- b. M1093, 5-ton cargo truck.
- c. M1094, 5-ton dump truck.
- d. M1095, 5-ton trailer

1-2. Special Considerations

CAUTION:

Only ammunition authorized by FM 10-500-53/MCRP 4-3.8/TO 13C7-18-41 may be airdropped.

NOTICE of EXCEPTION:

The procedures in this manual for installing the Suspension Sling Safety Ties may differ from those in FM 4-20.102/NAVSEASS400-AB-MMO-010/TO 13C7-1-5 an exception to FM 4-20.102 is granted. The procedures in this manual **MUST** be followed.

a. The loads covered in this manual may include hazardous material as defined in AFMAN(I) 24-204/TM 38-250. If included, the hazardous materials must be packaged, marked, and labeled as required by AFMAN(I) 24-204/TM 38-250.

b. Cover all wet cell batteries in service with plastic or nonflammable material.

c. Check fuel tanks to ensure that they do not exceed the fuel level.

d. A copy of this manual must be available to the joint airdrop inspectors during the before- and after-loading inspections.

1-3. Recommended Changes

The proponent of this publication is HQ TRADOC. You are encouraged to report any errors or omissions, and suggest ways for improving this manual.

Army personnel, send your comments on DA Form 2028 directly to:

AERIAL DELIVERY AND FIELD SERVICES
DEPARTMENT
US ARMY QUARTERMASTER CENTER AND
SCHOOL
1010 SHOP ROAD
FORT LEE VA 23801-1502

Air Force personnel, send your reports on AFTO Form 22 through:

HEADQUARTERS
AIR MOBILITY COMMAND (AMC/DOTX)
402 SCOTT DR, UNIT 3A1
SCOTT AFB IL 62225-5302

to:

AERIAL DELIVERY AND FIELD SERVICES
DEPARTMENT
US ARMY QUARTERMASTER CENTER AND
SCHOOL
1010 SHOP ROAD
FORT LEE VA 23801-1502

Also send information copies of AFTO Form 22 to:

WR-ALC/LKCB
460 RICHARD RAY BLVD SUITE 221
ROBINS AFB GA 31098-1640

Unless this publication states otherwise, masculine nouns and pronouns do not refer exclusively to men.

CHAPTER 2

RIGGING M1081, 2 1/2-TON CARGO TRUCK ON A 24-FOOT TYPE V PLATFORM FOR LOW-VELOCITY AIRDROP

Section I

RIGGING M1081, 2 1/2-TON CARGO TRUCK WITH BASIC LOAD

2-1. Description of Load

The M1081, 2 1/2-ton cargo truck (*Figure 2-1*) is rigged on a 24-foot, type V airdrop platform with five G-11 cargo parachutes.

The load consists of the M1081, 2 1/2-ton cargo truck and basic load. This load is 93 inches in height, 108 inches in width, 315 inches in length and has a rigged weight of 23,181 pounds.

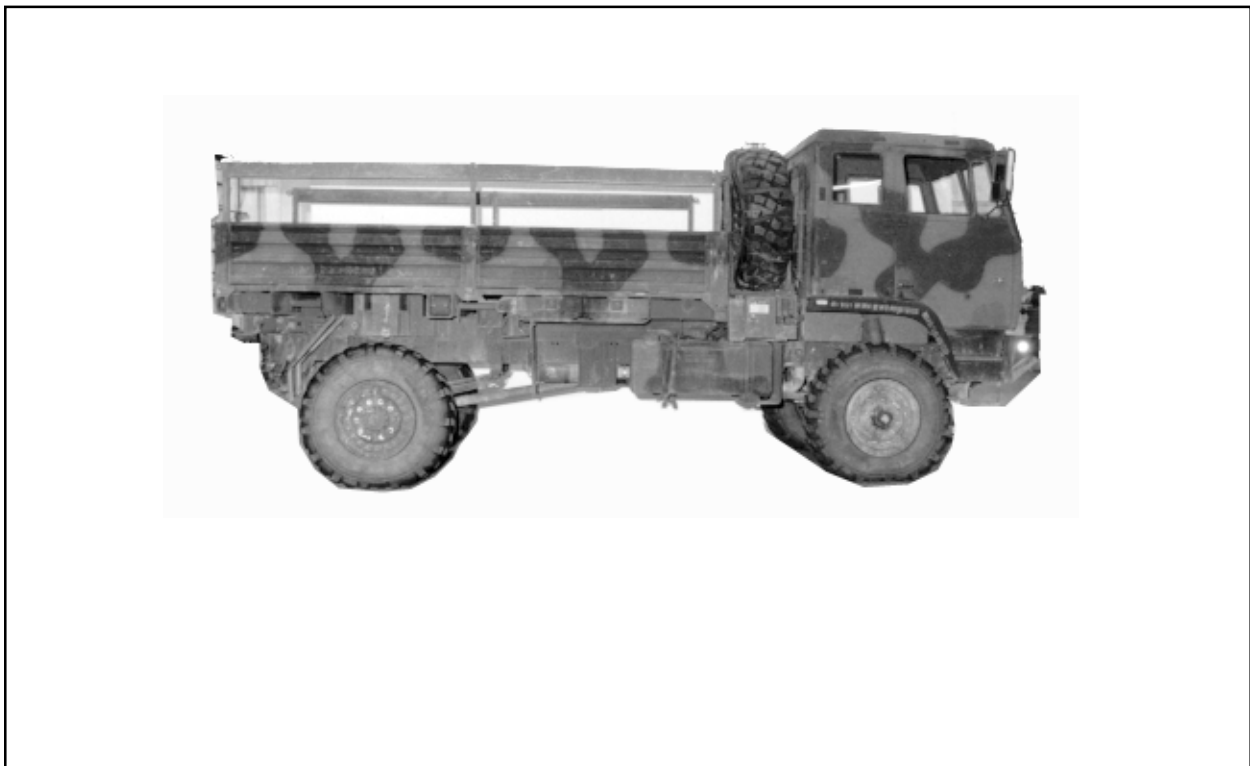
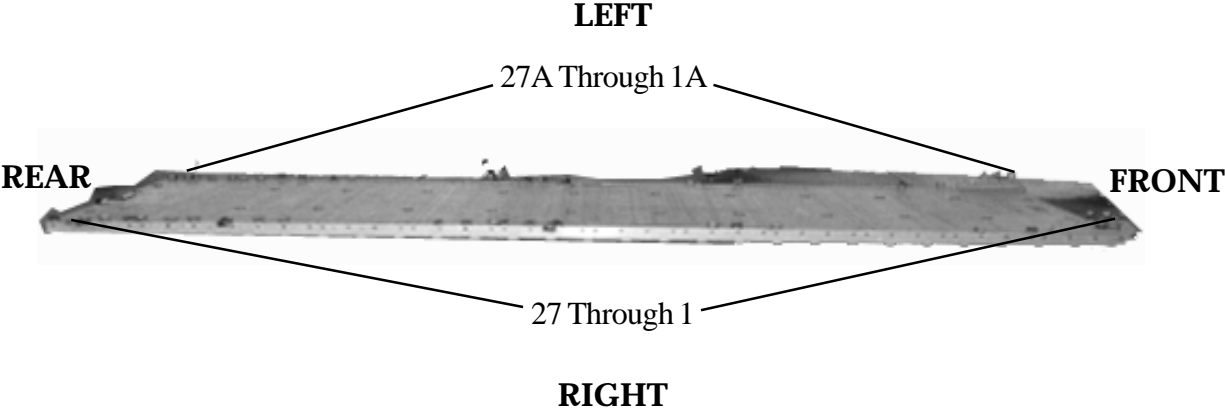

Figure 2-1. M1081, 2 1/2-ton cargo truck

2-2. Preparing Platform

Prepare a 24-foot, type V platform as shown in *Figure 2-2*.

NOTES: 1. The nose bumper may or may not be installed.
2. Measurements given in this section are from the front edge of the platform NOT from the front edge of the nose bumper.



LEFT
27A Through 1A
REAR **FRONT**
27 Through 1
RIGHT

Step:

1. Inspect, or assemble and inspect, a 24-foot, type V airdrop platform as outlined in TM 10-1670-268-20&P/TO 13C7-52-22.
2. Install a tandem multi-purpose link to each platform side rail using holes 1, 2, and 3.
3. Attach clevises to each tandem link using bushings 1, 2, (tripled), and 3.
4. Starting at the front of each platform side rail, install clevises using bushings bolted to holes 5, 7, 16, 18, 19, 26 (doubled), 27, 28, 29, 30, 31, 39, 41 (doubled), 42, 43, 44, 45, 46, 47, (tripled), and 48.
5. Starting at the front of the platform, number the clevises 1 through 27 on the right side and 1A through 27A on the left side.

Figure 2-2. Platform prepared

2-3. Preparing Honeycomb Stacks

Use the material in *Table 2-1* to prepare 10 honeycomb stacks as shown in *Figures 2-3 through 2-10*.

Table 2-1. Material needed to build honeycomb stacks.

Stack Number	Pieces	Width (Inches)	Length (Inches)	Material	Instructions
1	8	43	24	Honeycomb	See <i>Figure 2-3</i> .
	3	43	24	3/4-inch Plywood	
	3	2- by 8	43	Lumber	
	4	2- by 8	12	Lumber	
	4	12	7 1/2	3/4-inch Plywood	
	4	14	7	3/4-inch Plywood	
2	5	48	18	Honeycomb	See <i>Figure 2-4</i> .
	2	48	18	3/4-inch Plywood	
	2	2- by 6	18	Lumber	
	6	18	5 1/2	3/4-inch Plywood	
3	2	36	46	Honeycomb	See <i>Figure 2-5</i> .
	2	12	46	Honeycomb	
	12	18	46	Honeycomb	
	6	12	36	Honeycomb	
	4	48	46	3/4-inch Plywood	
	2	2- by 8	26 1/2	Lumber	
	1	7 1/2	26 1/2	1/2-inch Plywood	
	2	7 1/2	8	3/4-inch Plywood	
	1	8	16	3/4-inch Plywood	
	1	8	6	3/4-inch Plywood	
	1	10	10	3/4-inch Plywood	
	4	12	14	3/4-inch Plywood	
4	2	36	44	Honeycomb	See <i>Figure 2-6</i> .
	2	12	44	Honeycomb	
	12	18	44	Honeycomb	
	6	12	36	Honeycomb	
	3	48	44	3/4-inch Plywood	
	1	2- by 6	48	Lumber	
	2	2- by 12	34	Lumber	
	6	2- by 6	21	Lumber	
	6	2- by 12	12	Lumber	

Table 2-1. Material needed to build honeycomb stacks (continued).

Stack Number	Pieces	Width (Inches)	Length (Inches)	Material	Instructions
5	5	60	18	Honeycomb	See Figure 2-7.
	2	60	18	3/4-inch Plywood	
	2	2- by 6	18	Lumber	
	6	5 1/2	18	3/4-inch Plywood	
6	8	48	18	Honeycomb	See Figure 2-8.
	3	48	18	3/4-inch Plywood	
	4	2- by 6	45	Lumber	
	6	2- by 6	8	Lumber	
	3	2- by 6	33	Lumber	
7	1	18	96	Honeycomb	See Figure 2-9.
8	1	18	96	Honeycomb	See Figure 2-9.
9	1	18	74	Honeycomb	See Figure 2-10.
10	1	18	74	Honeycomb	See Figure 2-10.

NOTE: On all stacks the plywood must be cut to fit lumber. **EXAMPLE:** An 11 1/2- by 24 inch piece of plywood sits on a 2- by 12- by 24-inch piece of lumber but hangs over a 1/2 inch on the 11 1/2 inch side. Cut it to 11 by 24 inches to insure it fits. This is not due to improper measurements but to the fact that lumber varies in true sizes.

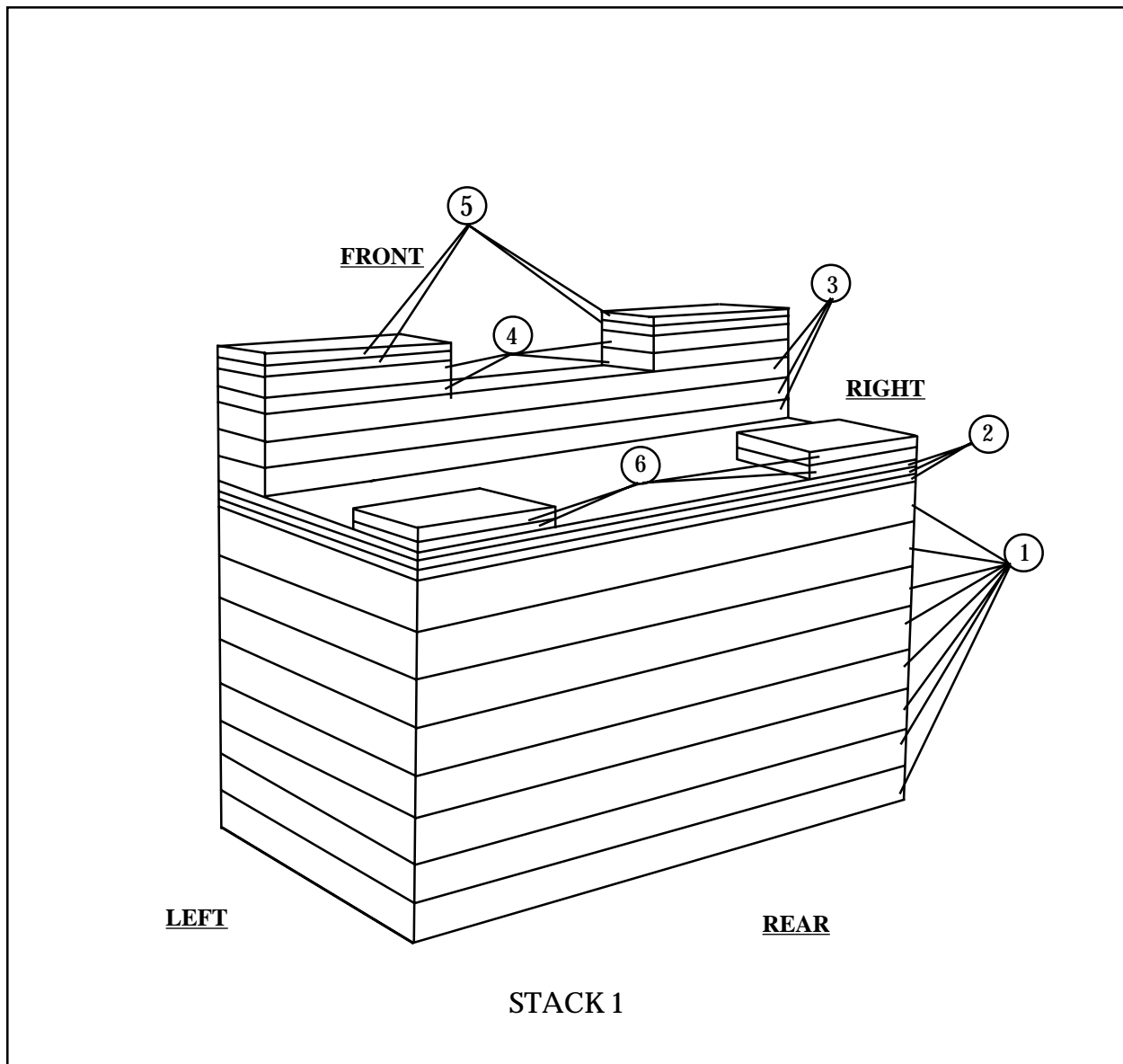

- ① Glue eight 43- by 24-inch pieces of honeycomb together to form a base.
- ② Glue and nail three 43- by 24-inch pieces of 3/4-inch plywood together. Glue the plywood to the top of the base.
- ③ Glue and nail three 2- by 8- by 43-inch pieces of lumber together. Center and glue the lumber flush with the front of base.
- ④ Glue and nail two 2- by 8- by 12-inch pieces of lumber together. Repeat with remaining two pieces, forming two stacks. Glue and nail one stack to the right side, and the other stack to the left side of previous 2- by 8- by 43-inch piece of lumber.
- ⑤ Glue and nail two 12- by 7 1/2- by 3/4-inch pieces of plywood together. Repeat with remaining two pieces, forming two stacks. Glue and nail one stack to the right side, and the other stack to the left side of previous 2- by 8- by 12-inch piece of lumber.
- ⑥ Glue and nail two 14- by 7- by 3/4-inch pieces of plywood together. Repeat with remaining two pieces, forming two stacks. Glue one stack to the rear right side, and the other stack to the rear left side of base.

Figure 2-3. Stack 1 prepared

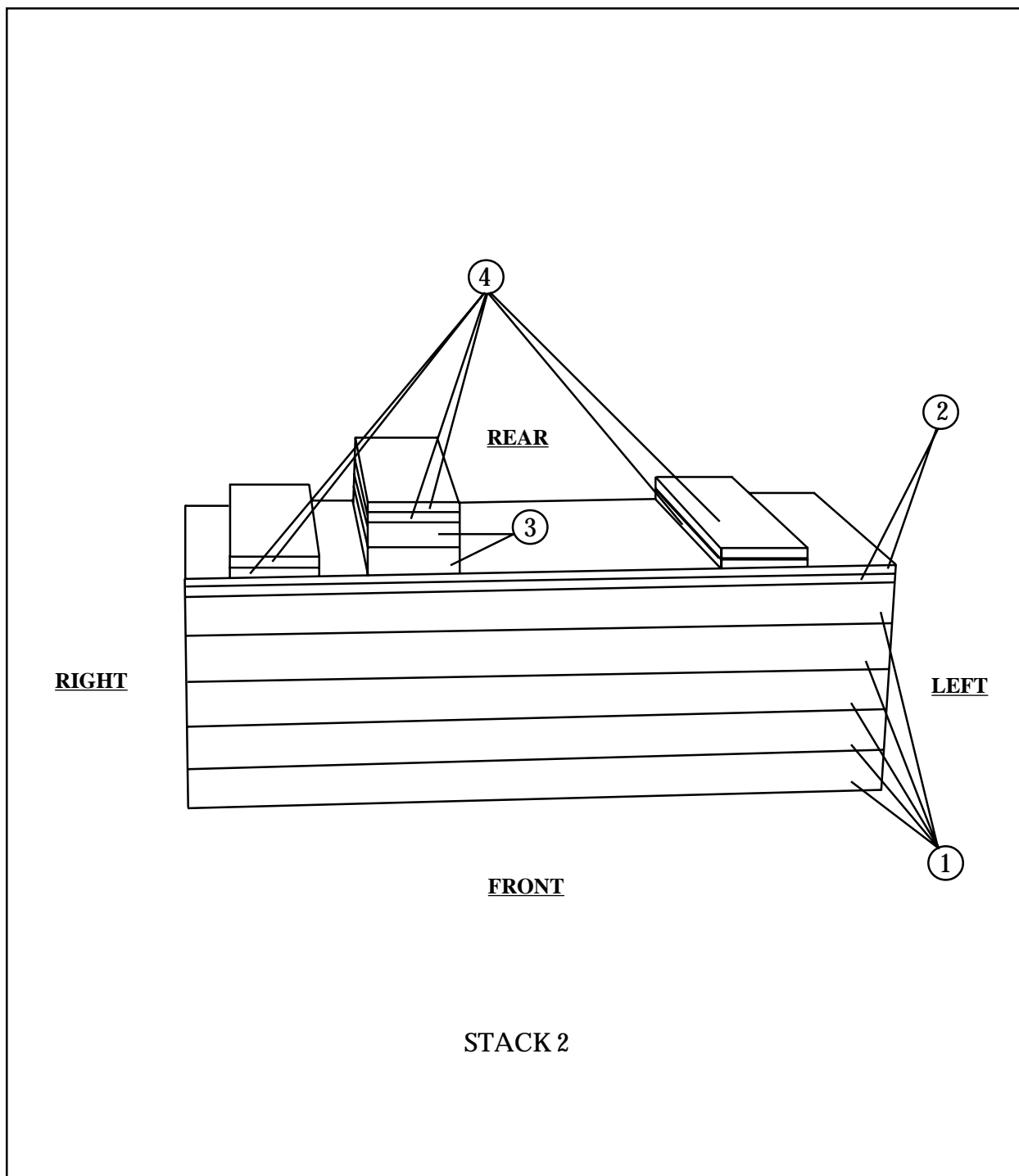

- ① Glue five 18- by 48-inch pieces of honeycomb together to form base.
- ② Glue and nail two 18- by 48-inch pieces of 3/4-inch plywood together. Glue to top of base.
- ③ Glue and nail two 2- by 18- by 48-inch pieces of lumber together. Glue and nail 13 inches from the right edge of the 18- by 48-inch pieces of plywood.
- ④ Glue and nail two 18- by 5 1/2-inch pieces of 3/4-inch plywood together. Repeat two more times with remaining four pieces, forming three stacks. Glue and nail one stack 3 inches from right edge of base. Glue and nail one stack on top of the 2- by 6- by 18-inch piece of lumber. Glue remaining stack 7 inches from the left side of base.

Figure 2-4. Stack 2 prepared

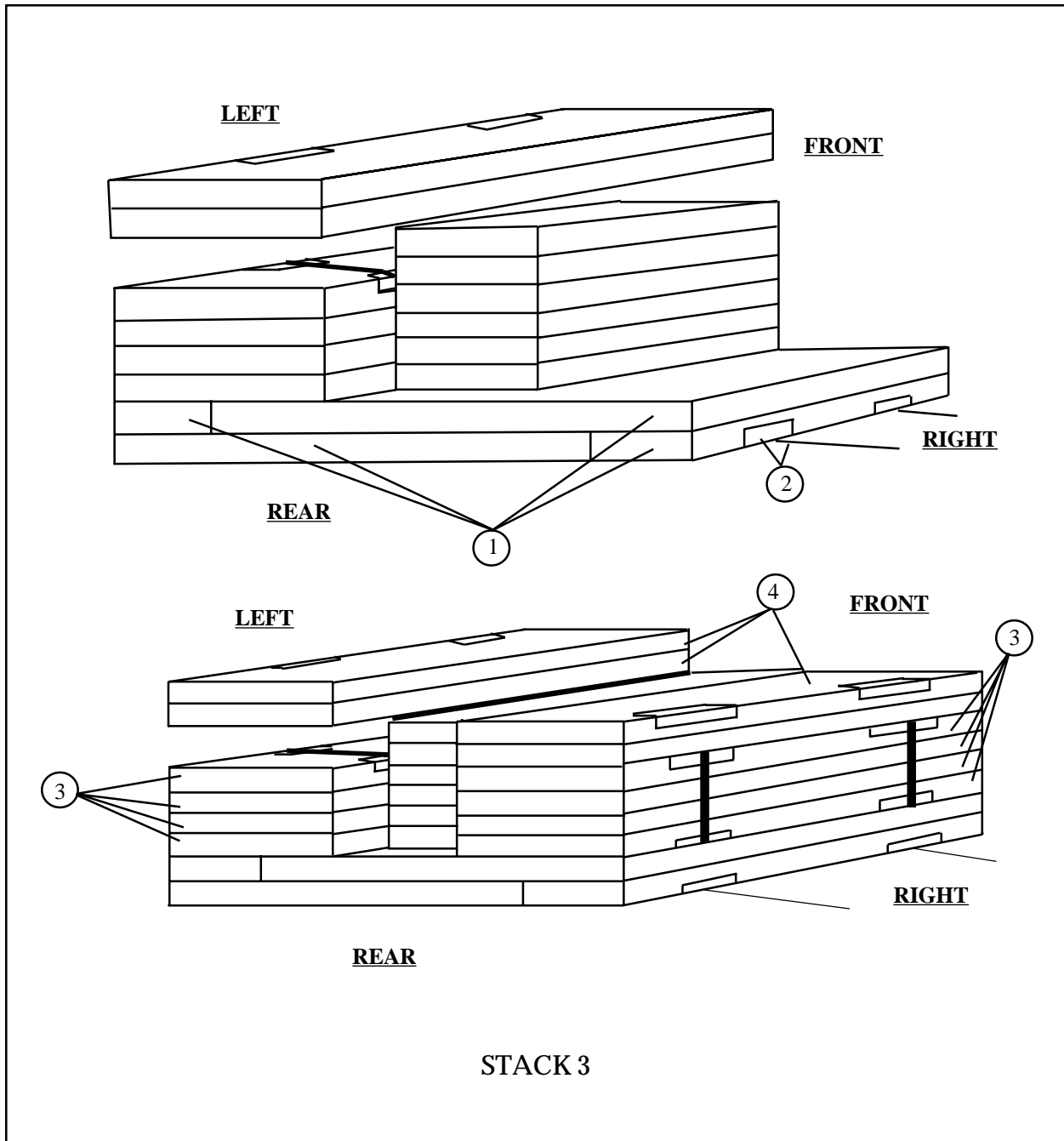

STACK 3

- ① Position a 36- by 46-inch piece of honeycomb beside a 12- by 46-inch piece of honeycomb. Alternate and glue a 36- by 46-inch piece of honeycomb and a 12- by 46-inch piece of honeycomb on top of the pieces of honeycomb to form the base.
- ② Place length of cloth backed tape on the bottom outer edges of the base. Position two 13-foot lengths of type III nylon cord under the base aligned with the strips of tape.
- ③ Form two stacks by gluing four 12- by 46-inch pieces of honeycomb together. Place length of tape on all edges. Run two lengths of 1/2-inch tubular nylon webbing over the strips of tape and around the stack. Secure and tie with a square knot on the outside of the stack. Place on the left and right sides of base (**Do NOT glue to base**).
- ④ Form two stacks by gluing two 12- by 46-inch pieces of honeycomb together. Place length of cloth backed tape on the outer edges (**Do NOT glue to stacks**). Position one stack on each of the previous stacks.

Figure 2-5. Stack 3 prepared

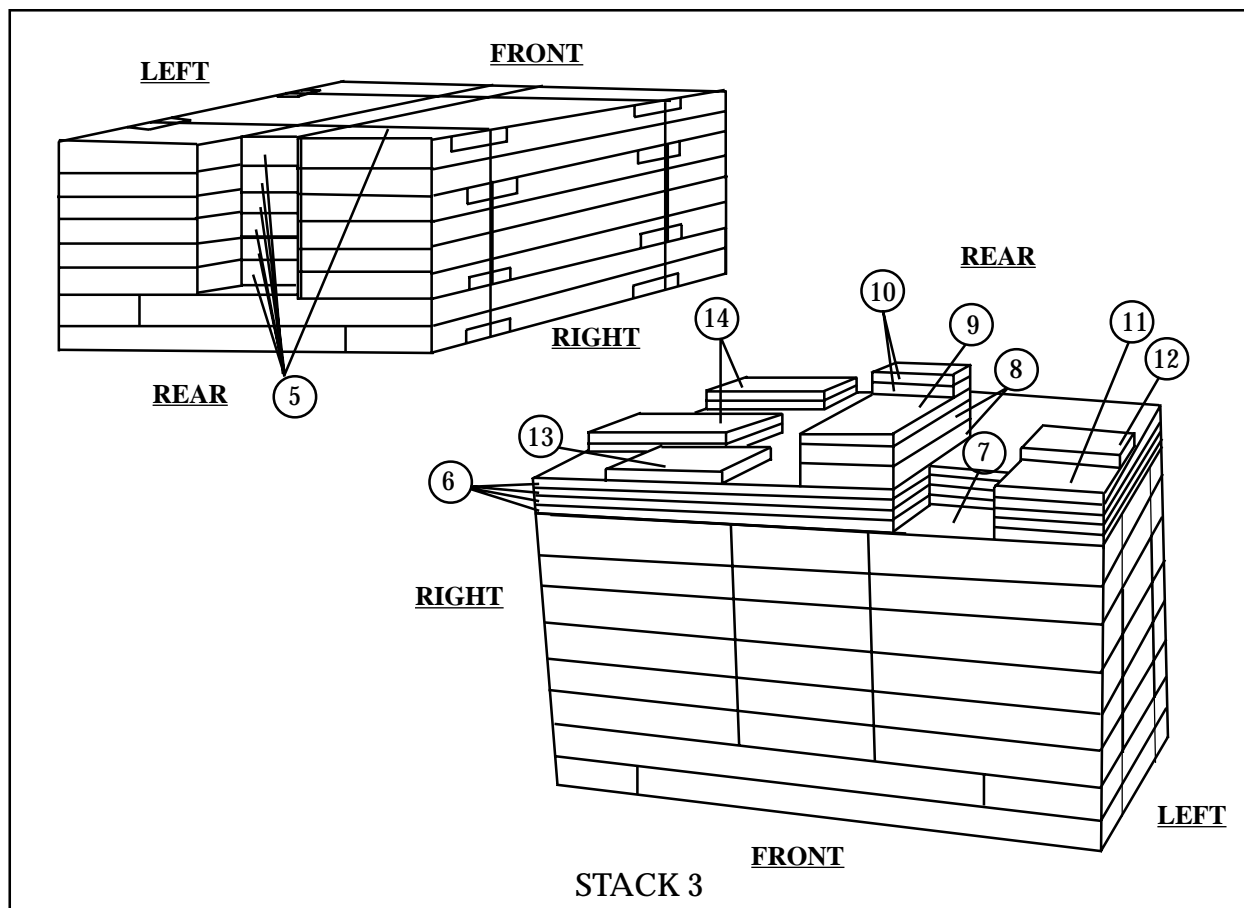

- 5 Glue six 12- by 36-inch pieces of honeycomb together to form a stack. Position between 18- by 46-inch stacks and flush with the front of base (**Do NOT glue to base**). Secure and tie the type III nylon cord around the completed honeycomb stack.
- 6 Glue and nail four 48- by 46-inch pieces of 3/4-inch plywood together. (**Do not build lumber stack on honeycomb stack. The lumber will be placed on the stack later.**)
- 7 Cut an 8-inch long, 12-inch deep cutout in the front of each of the 48-inch sides of plywood and 8 inches from the left 46 inch side of the plywood.
- 8 Glue and nail two 2- by 8- by 26 1/2-inch pieces of lumber flush with front edge and right edge of cutout. Glue and nail each piece separately.
- 9 Glue and nail a 7 1/2- by 26 1/2-inch piece of 1/2-inch plywood on top of the 2- by 8- by 26 1/2-inch piece of lumber.
- 10 Glue and nail two 7 1/2- by 8-inch pieces of 3/4-inch plywood. Glue the plywood flush and to the rear of the 7 1/2- by 26 1/2-inch pieces of 1/2-inch plywood.
- 11 Glue and nail a 8- by 16-inch piece of 3/4-inch plywood flush with front left edge of the 48- by 46-inch piece of 3/4-inch plywood.
- 12 Glue and nail a 8- by 6-inch piece of 3/4-inch plywood flush with rear left edge of the 8- by 16-inch piece of 3/4-inch plywood.
- 13 Glue and nail a 10- by 10-inch piece of 3/4-inch plywood flush with front edge, 8 inches from right side.
- 14 Form two stacks by gluing and nailing two 12- by 14-inch pieces of 3/4-inch plywood together. Position one stack against the rear edge of the 10- by 10-inch piece of 3/4-inch plywood. Ensure the 12 inch side is flush with right edge of the 48- by 46-inch piece of 3/4-inch plywood. Glue and nail the other stack flush with right rear edge of the 48- by 46-inch piece of 3/4-inch plywood. Ensure the 12 inch side is flush with right edge of the 48- by 46-inch piece of 3/4-inch plywood. Glue all lumber to honeycomb base.

Figure 2-5. Stack 3 prepared (continued)

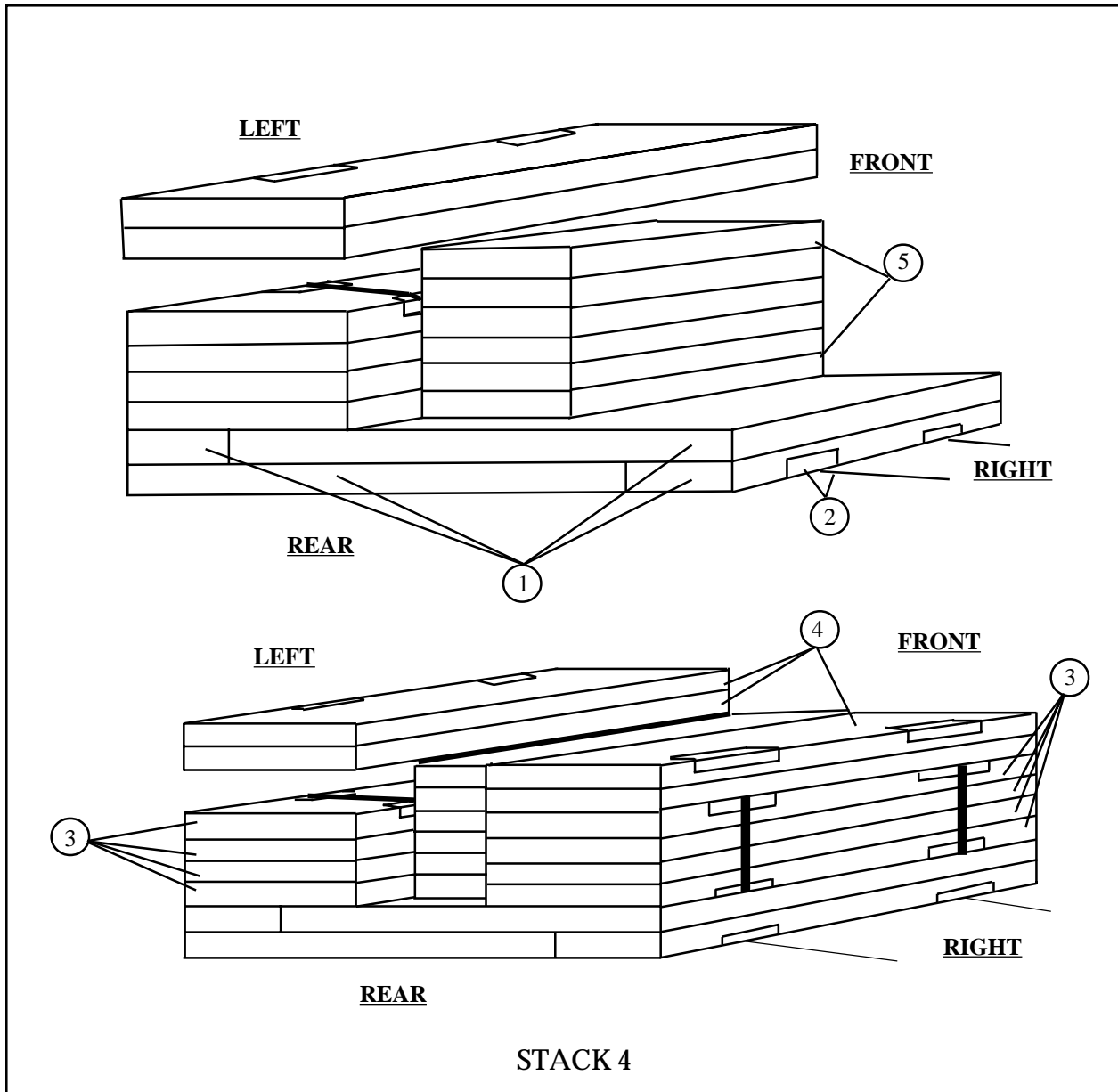

STACK 4

- ① Position a 36- by 44-inch piece of honeycomb beside a 12- by 44-inch piece of honeycomb. Alternate and glue a 36- by 44-inch piece of honeycomb and a 12- by 44-inch piece of honeycomb on top of the pieces of honeycomb to form the base.
- ② Place length of cloth backed tape on the bottom outer edges of the base. Position two 13-foot lengths of type III nylon cord under the base aligned with the strips of tape.
- ③ Form two stacks by gluing four 18- by 44-inch pieces of honeycomb together. Place length of tape on all edges. Run two lengths of 1/2-inch tubular nylon webbing over the strips of tape and around the stack. Secure and tie with a square knot on the outside of the stack. Place on the left and right sides of base (**Do NOT glue to base**).
- ④ Form two stacks by gluing two 12- by 44-inch pieces of honeycomb together. Place length of cloth backed tape on the outer edges (**Do NOT glue to stacks**). Position one stack on each of the previous stacks.
- ⑤ Glue six 12- by 36-inch pieces of honeycomb together to form a stack. Position between 18- by 44-inch stacks and flush with the front of base (**Do NOT glue to base**). Secure and tie the type III nylon cord around the completed honeycomb stack.

Figure 2-6. Stack 4 prepared

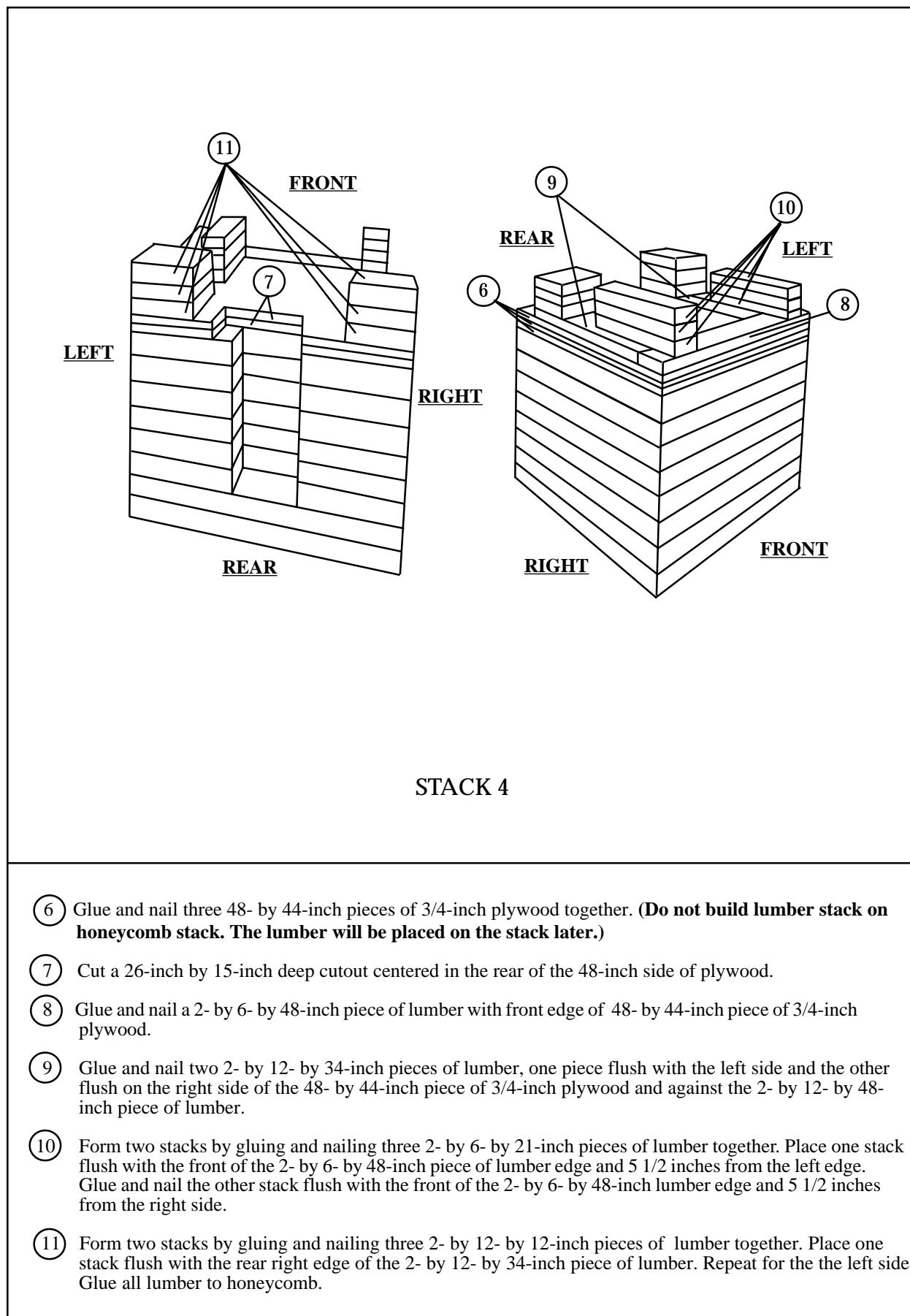
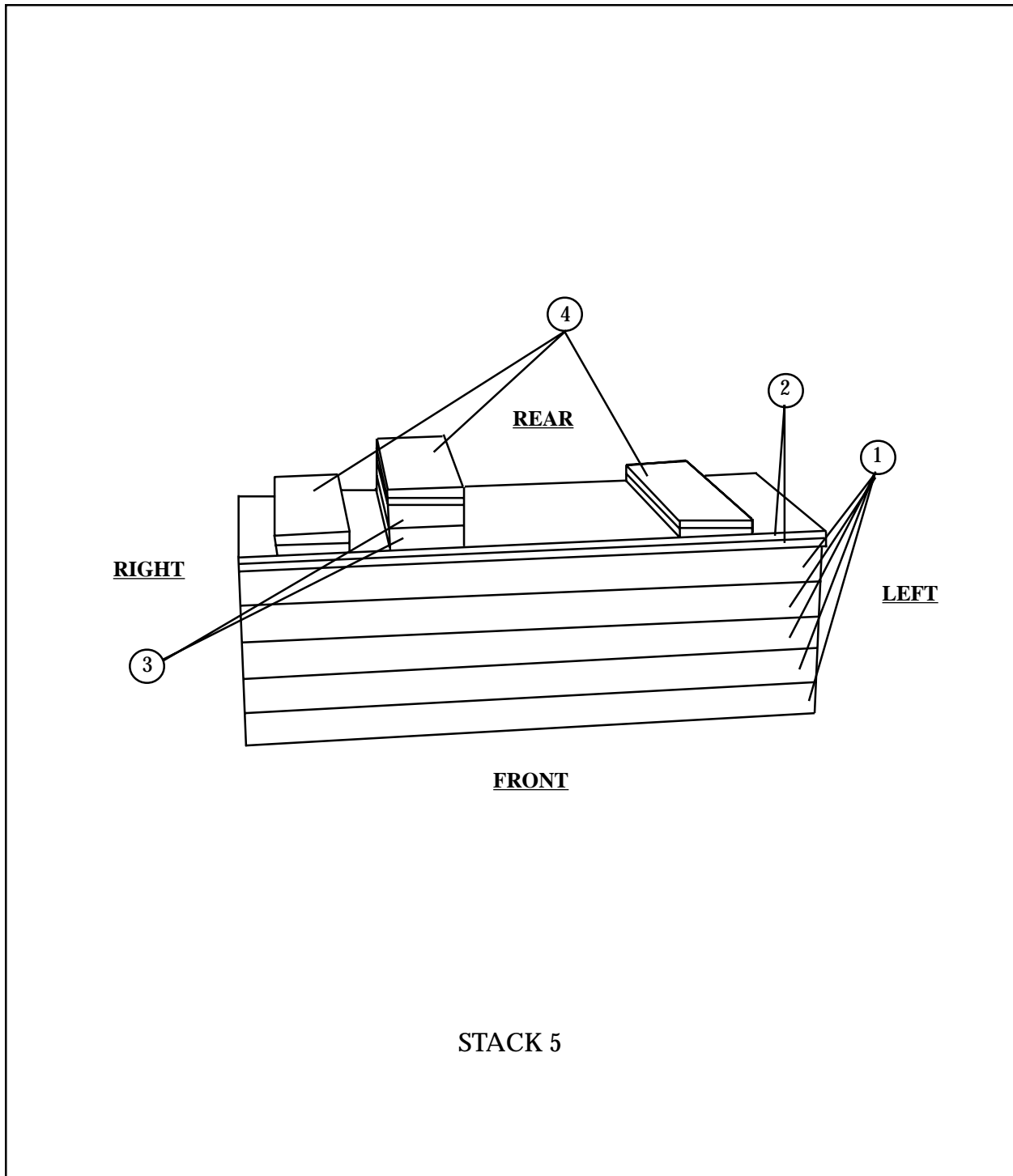

Figure 2-6. Stack 4 prepared (continued)



STACK 5

- ① Glue five 18- by 60-inch pieces of honeycomb together to form base.
- ② Glue and nail two 18- by 60-inch pieces of 3/4-inch plywood together. Glue to top of base.
- ③ Glue and nail two 2- by 6- by 18-inch pieces of lumber together. Glue and nail 16 1/2 inches from right edge of 18- by 60-inch piece of 3/4-inch plywood.
- ④ Form three stacks by gluing and nailing two 5 1/2- by 18-inch pieces of 3/4-inch plywood together. Glue one stack 5-inches from right edge of base. Glue another stack on top of the 2- by 6- by 18-inch piece of lumber. Glue the remaining stack 5 inches from the left side of base. Glue all lumber to honeycomb.

Figure 2-7. Stack 5 prepared

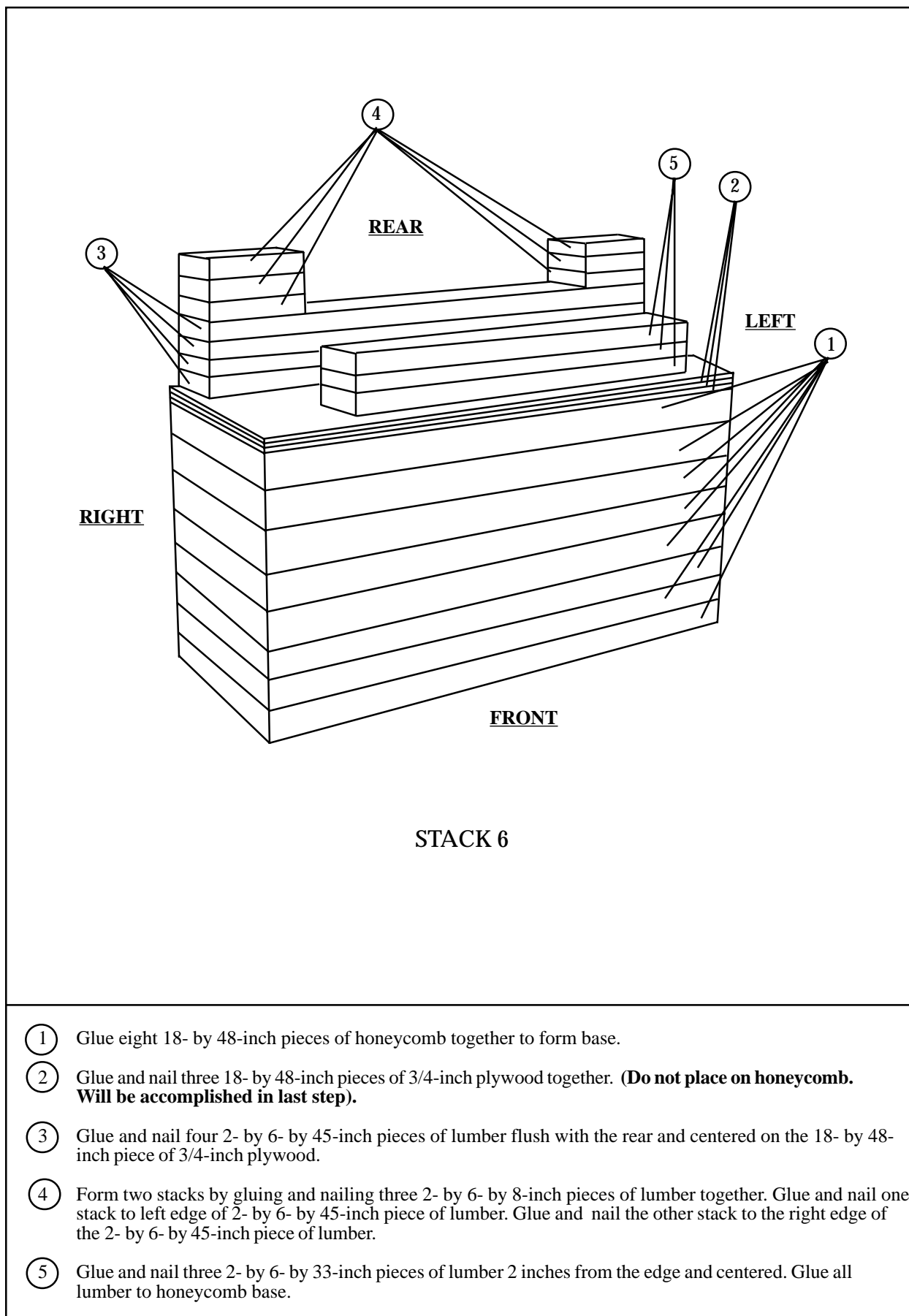

- ① Glue eight 18- by 48-inch pieces of honeycomb together to form base.
- ② Glue and nail three 18- by 48-inch pieces of 3/4-inch plywood together. **(Do not place on honeycomb. Will be accomplished in last step).**
- ③ Glue and nail four 2- by 6- by 45-inch pieces of lumber flush with the rear and centered on the 18- by 48-inch piece of 3/4-inch plywood.
- ④ Form two stacks by gluing and nailing three 2- by 6- by 8-inch pieces of lumber together. Glue and nail one stack to left edge of 2- by 6- by 45-inch piece of lumber. Glue and nail the other stack to the right edge of the 2- by 6- by 45-inch piece of lumber.
- ⑤ Glue and nail three 2- by 6- by 33-inch pieces of lumber 2 inches from the edge and centered. Glue all lumber to honeycomb base.

Figure 2-8. Stack 6 prepared

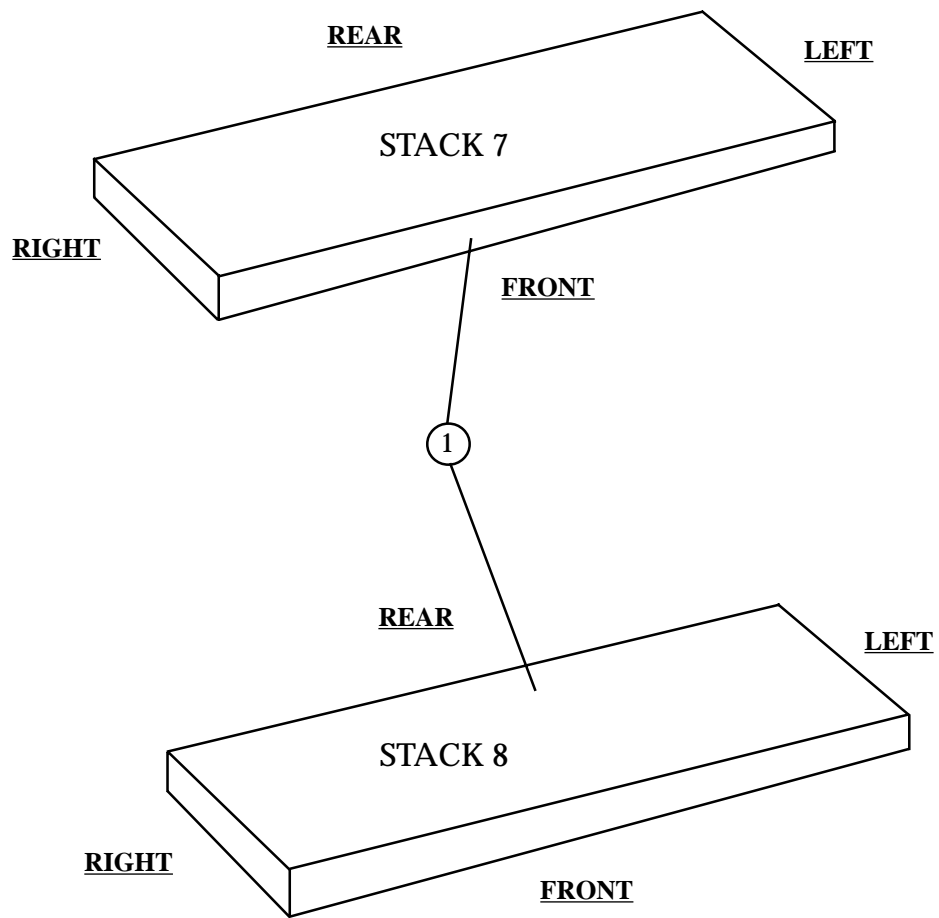

① Cut two 18- by 96-inch pieces of honeycomb. No further preparation is needed.

Figure 2-9. Stacks 7 and 8 prepared

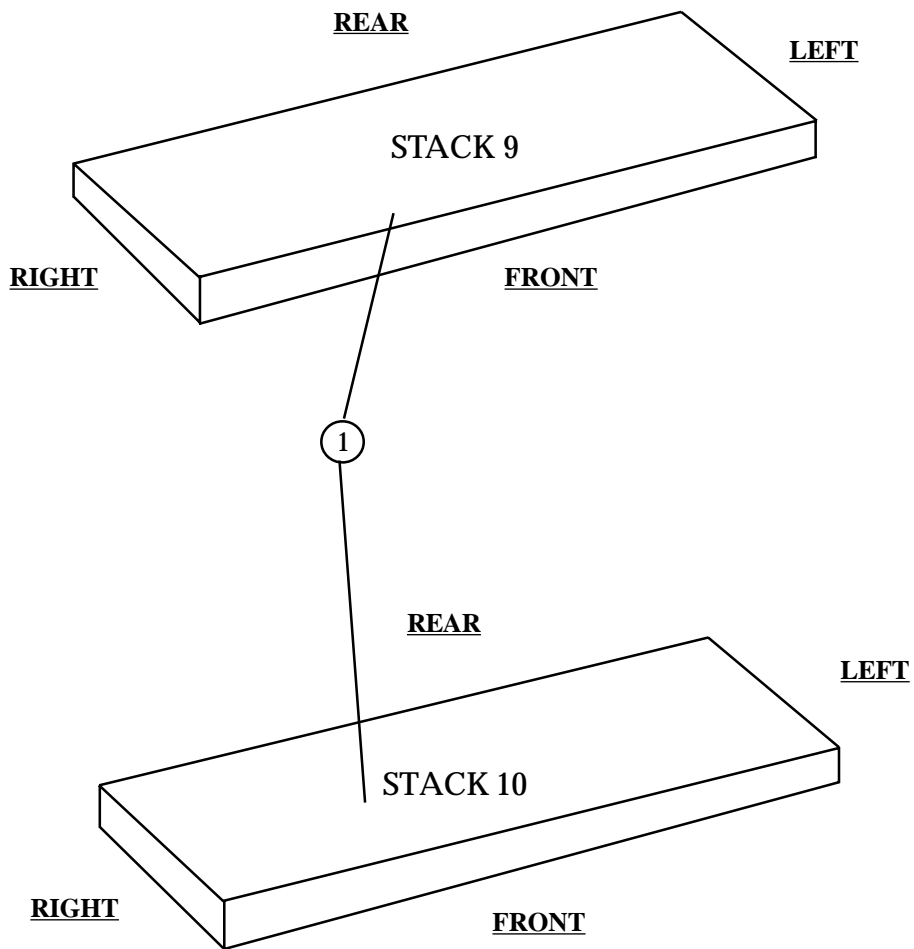

① Cut two 18- by 74-inch pieces of honeycomb. No further preparation is needed.

Figure 2-10. Stacks 9 and 10 prepared

2-4. Positioning Honeycomb Stacks

Position the honeycomb stacks as shown in *Figure 2-11*.

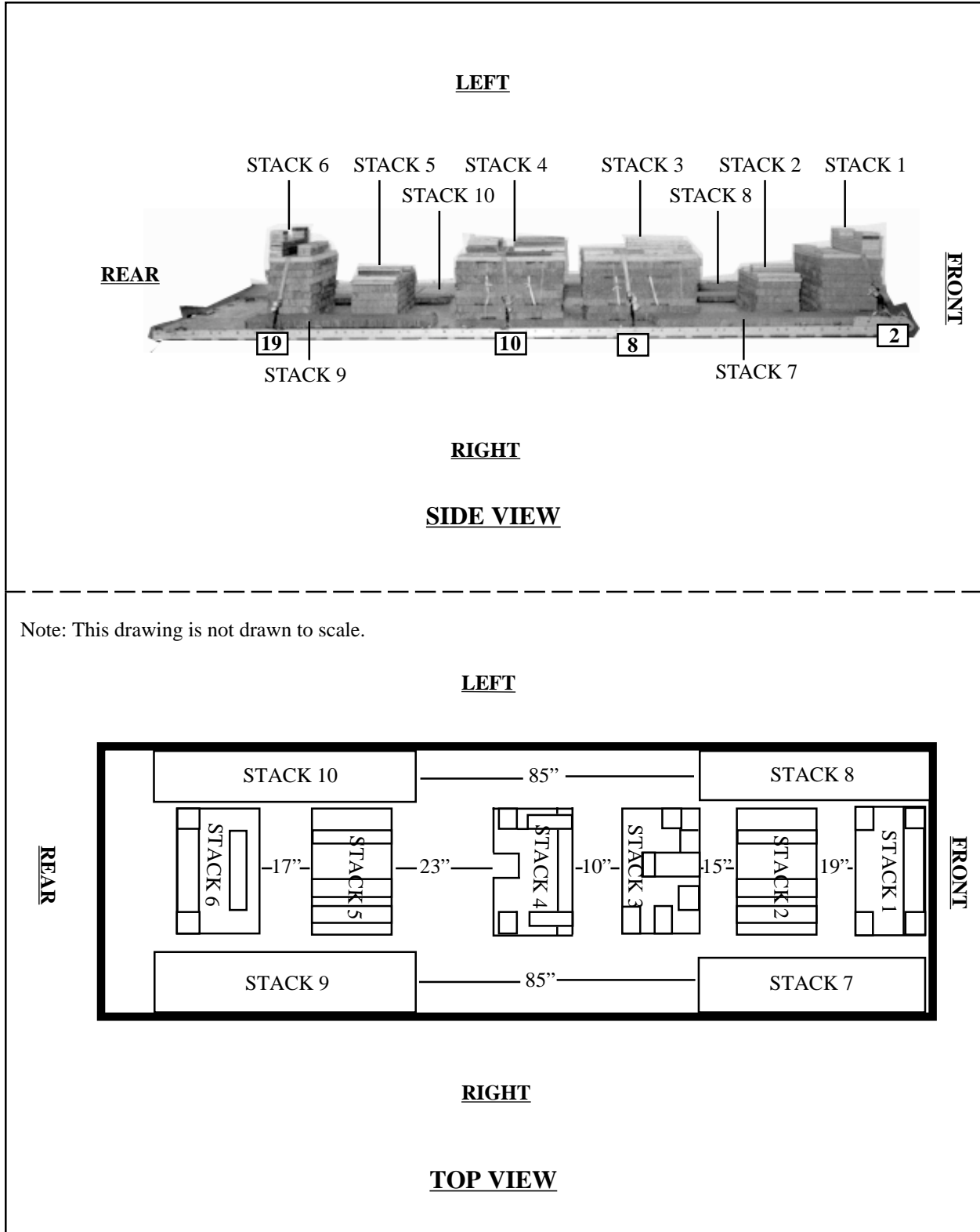

Figure 2-11. Honeycomb stacks positioned on platform

Stack Number	Instructions
1	Position stack 1, centered and flush with the front edge of the platform. Secure the stack by passing a lashing through clevis 2A and it's own D-ring. Route the lashing over the stack and secure it with a loadbinder to clevis 2.
2	Position stack 2, 19 inches from stack 1, 22 inches from the left side rail, and 28 inches from right side rail.
3	Position stack 3, 15 inches from stack 2, 30 1/4 inches from the left side rail and 19 1/4 inches from the right side rail. Secure the stack by passing a lashing through clevis 8A and it's own D-ring. Route the lashing over the stack and secure it with a loadbinder to clevis 8.
4	Position stack 4, 10 inches from stack 3, 25 1/2 inches from the left side rail and 24 1/4 inches from the right side rail. Secure the stack by passing a lashing through clevis 10A and it's own D-ring. Route the lashing over the stack and secure it with a loadbinder to clevis 10.
5	Position stack 5, 23 inches from stack 4, 19 1/4 inches from the left side rail, and 18 inches from right side rail.
6	Position stack 6, 17 inches from stack 5, 26 inches from the left side rail and 23 inches from the right side rail. Secure the stack by passing a lashing through clevis 19A and it's own D-ring. Route the lashing over the stack and secure it with a loadbinder to clevis 19.
7	Position stack 7, flush with the front edge of the platform and flush with the right side rail.
8	Position stack 8, flush with the front edge of the platform and flush with the left side rail.
9	Position stack 9, 85 inches from the rear of stack 7 and flush with the right side rail.
10	Position stack 10, 85 inches from the rear of stack 8 and flush with the left side rail.

Figure 2-11. Honeycomb stacks positioned on platform (Continued)

2-5. Preparing Truck

Prepare the M1081 truck as described below and as shown in *Figure 2-12*.

- a.* Make sure the fuel tank is 3/4 full.
- b.* Make sure the batteries and compartment comply with AFJMAN 24-204/TM 38-250.

The following is a list of materials used for truck preparation.

PIECES	WIDTH (inches)	LENGTH (inches)	MATERIAL
1	36	36	Honeycomb
1	36	80	Honeycomb
2	18	60	Honeycomb
10	2- by 6	13	Lumber
2	4- by 4	6	Lumber
2	4- by 4	15	Lumber
4	2- by 4	6	Lumber
1	10	10	3/4-inch Plywood
3	2- by 6	6	Lumber
1	36	96	Honeycomb
4	1/2	10	Bolts (washers and nuts)

- NOTES:**
1. The truck should arrive at the rigging site with the gun turret removed from roof and replaced with flat insert.
 2. The cargo/troop carrier cover, bows, cargo/troop carrier cover poles, bed stakes, seat bars, seats and side rails located in the rear of the truck should be removed and packed as basic load.

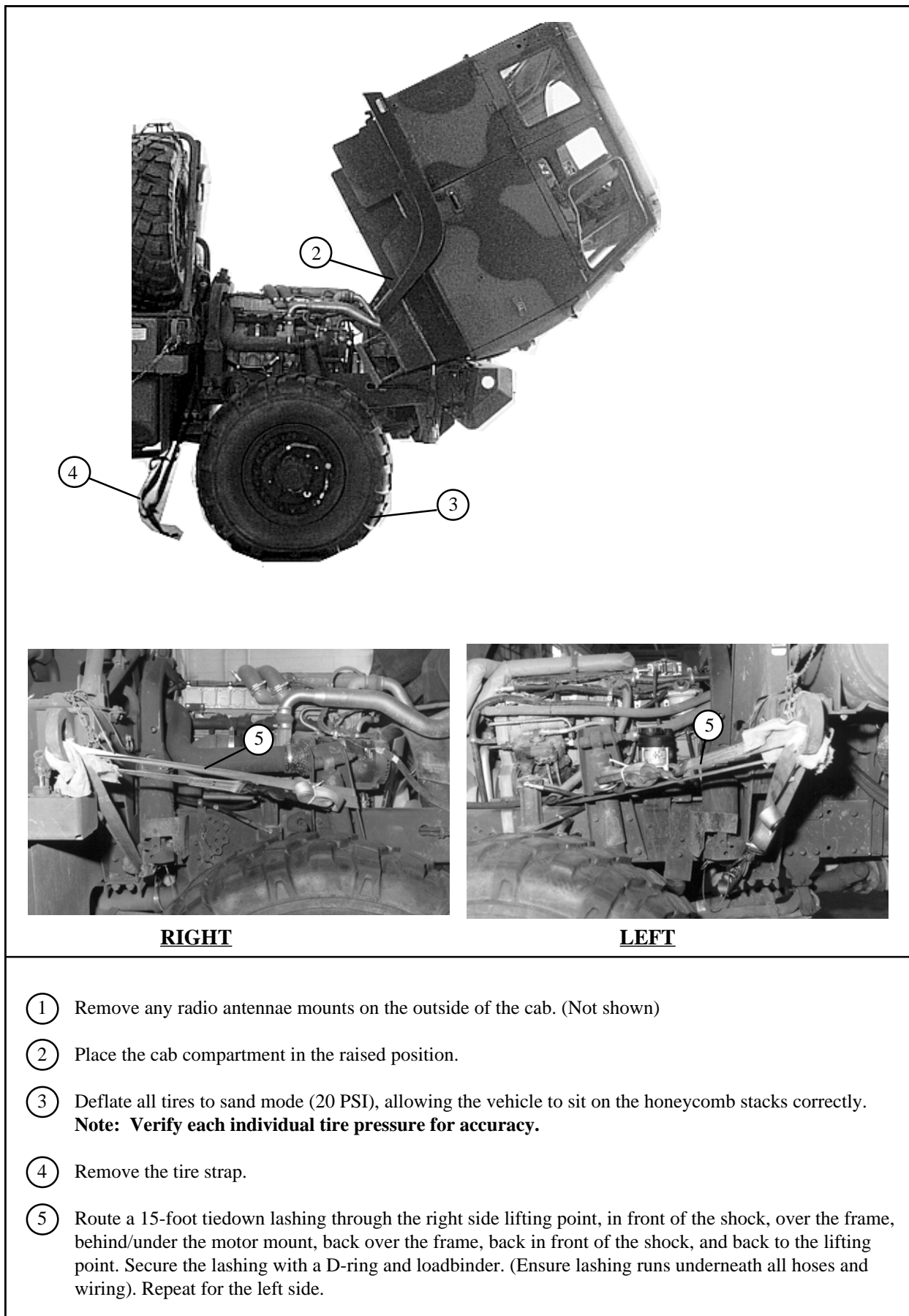
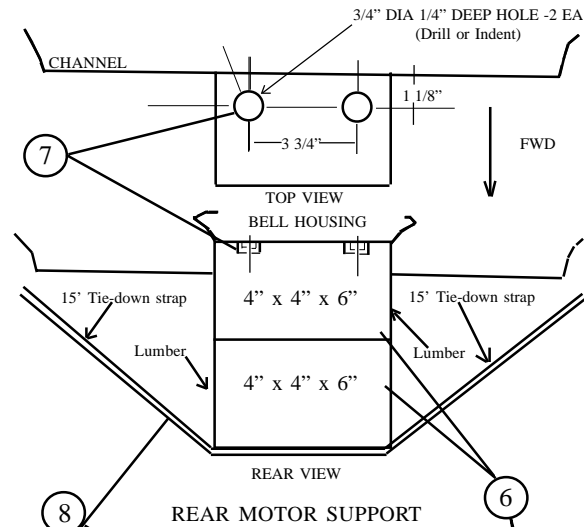

Figure 2-12. Truck prepared

Note: This drawing is not drawn to scale.



- ⑥ Cut two 4- by 4- by 6-inch pieces of lumber.
- ⑦ Countersink two holes 3/4-inch in diameter, 1/4-inch deep, and 1 1/8 inch from the edge on the 6 inch side, with a 3 3/4 inch center to center hole measurement in one piece of 4- by 4- by 6-inch lumber. Place the other 4 - by 4- by 6-inch piece of lumber under the first piece of lumber and tape them together leaving the holes exposed.
- ⑧ Place the countersunk holes of the 4- by 4- by 6-inch piece of lumber over the bolts in the bell housing. Route a 30-foot lashing through the right side lifting point under the 4- by 4- by 6-inch piece of lumber and through the left side lifting point, and back under the 4- by 4- by 6-inch piece of lumber. Secure with a D-ring and loadbinder.

Figure 2-12. Truck prepared (Continued)

Note: This drawing is not drawn to scale.

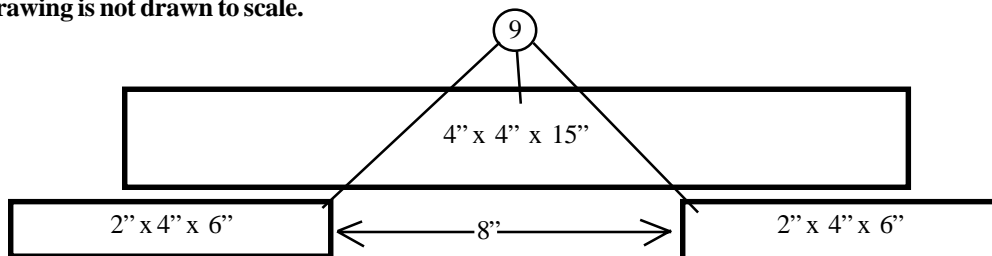

- ⑨ Glue and nail together one 4- by 4- by 15-inch piece of lumber and two 2- by 4- by 6-inch pieces of lumber for each axle.
- ⑩ Position them on top of the right and left axles and secure with type III nylon cord.
- ⑪ Position a 10- by 10- by 3/4-inch piece of plywood and three 2- by 6- by 6-inch pieces of lumber against the oil pan and front of the engine.

Figure 2-12. Truck prepared (Continued)



- ⑫ Route a 15-foot lashing in rear of motor mounts around the left and right main frames (under all hoses). Secure the lumber and plywood with D-ring and loadbinder.

Figure 2-12. Truck prepared (Continued)



- ⑬ Place the cab in the lowered position.
- ⑭ Remove the spare tire from the rack and leave the spare tire carrier down.
- ⑮ Remove the davit. (It is attached to the back of cab.) (Not shown)
- ⑯ Remove the windshield wipers and stow the bolts and blades in the cab. (Not shown)

Figure 2-12. Truck prepared (Continued)

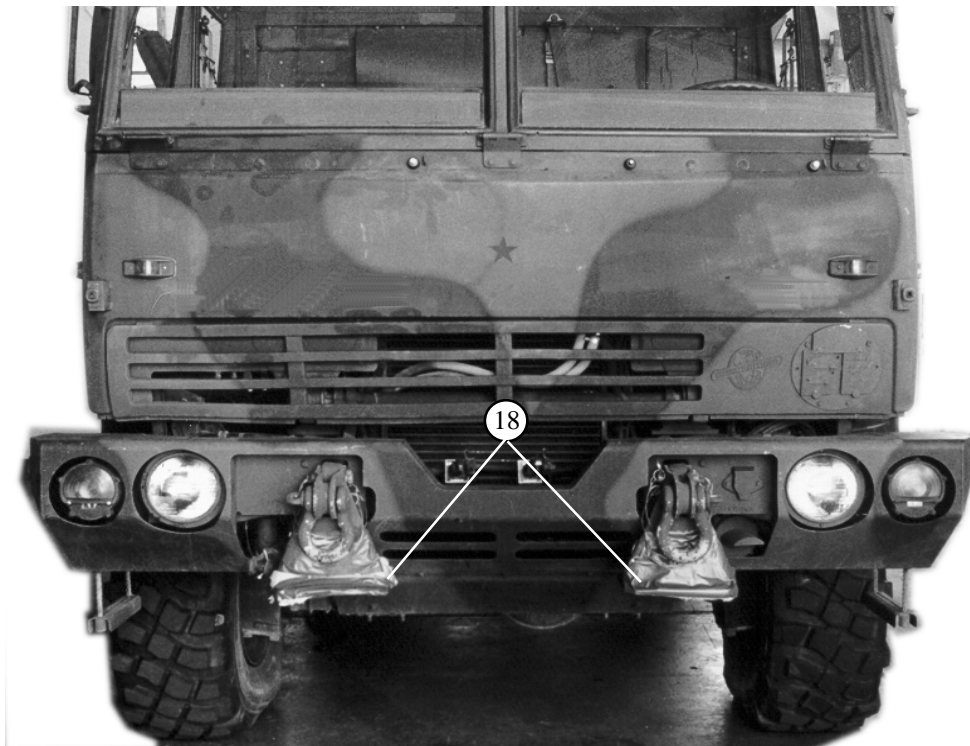
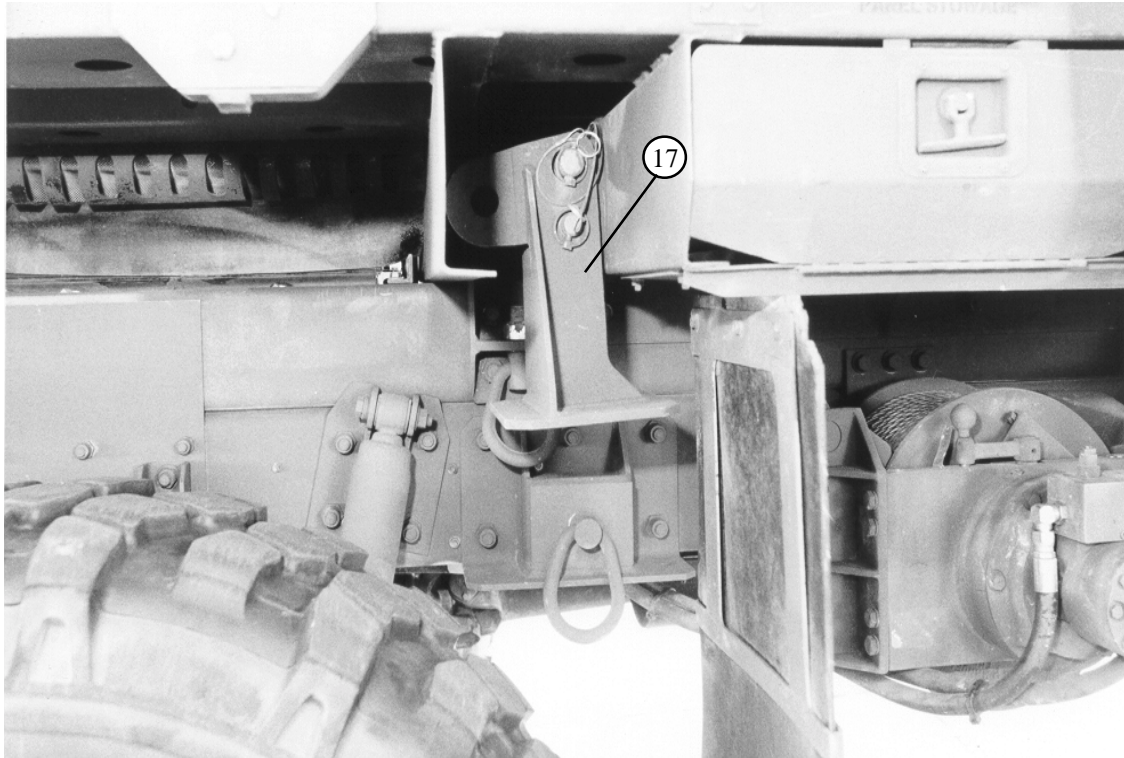

- ①7 Remove the front support brackets from under the bed of the truck.
- ①8 Install them on the front of the vehicle and wrap the outside edges with cellulose wadding and tape.

Figure 2-12. Truck prepared (Continued)

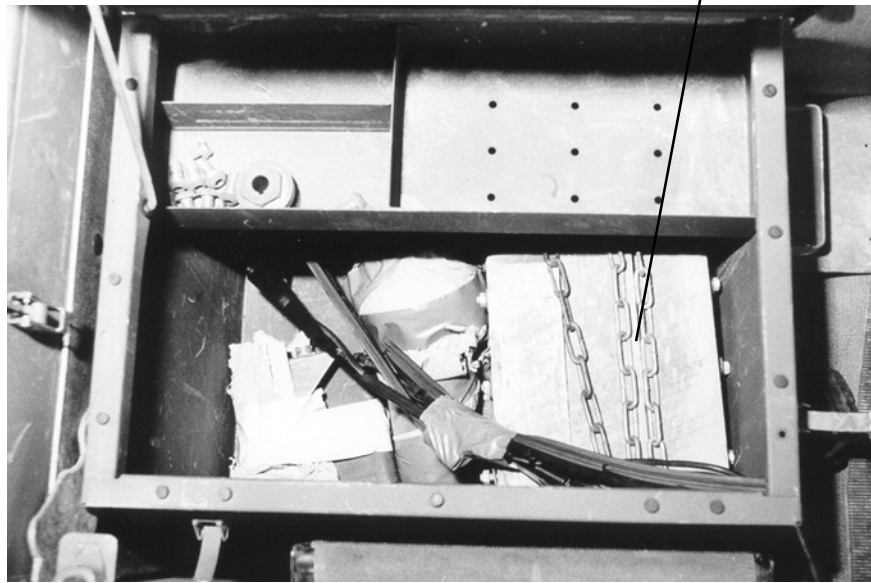
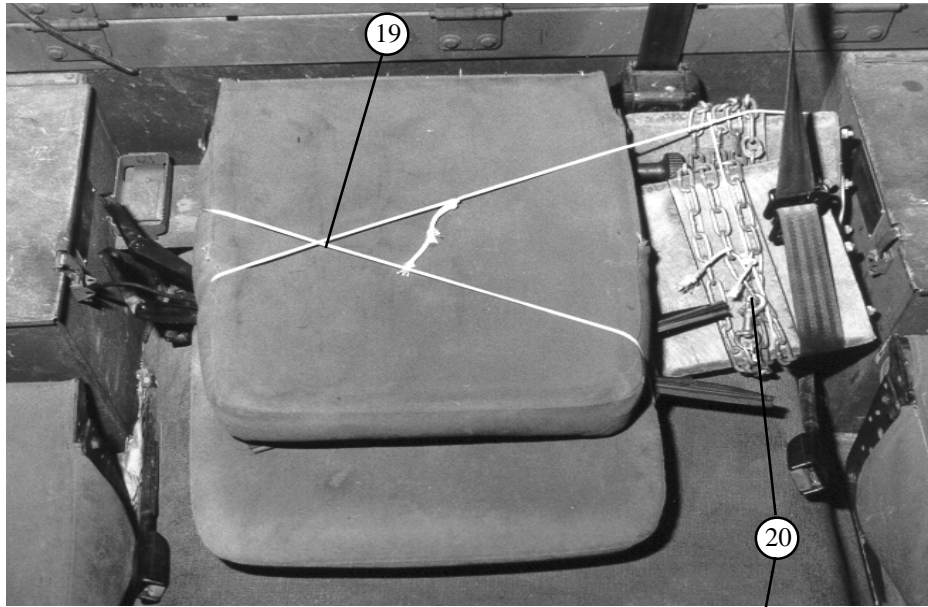

- ①⑨ Secure the chock blocks in cab or in storage box.
- ②⑩ Lower the seats and secure with type III nylon cord.
- ②⑪ Secure the fire extinguisher with type III nylon cord. (Not shown)

Figure 2-12. Truck prepared (Continued)

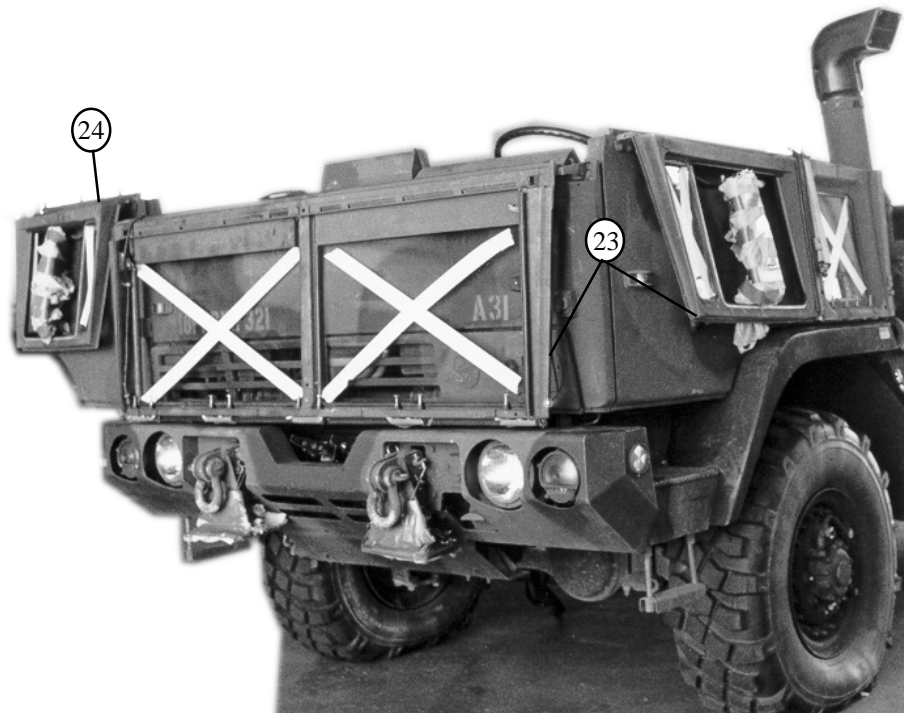
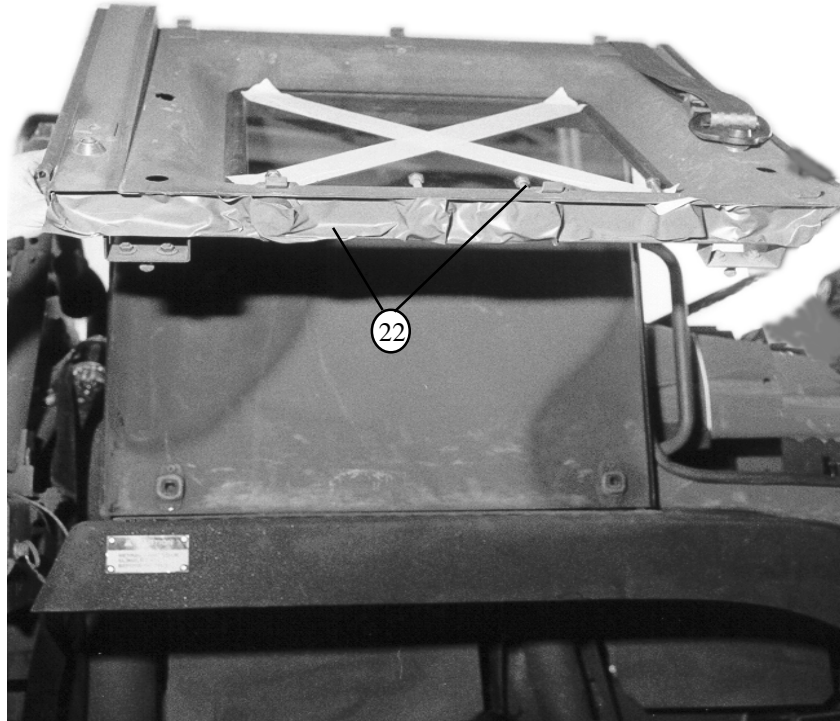

- ②② Remove the roof and secure the roof bolts with tape.
- ②③ Fold down the windows, windshield and rear of the cab.
- ②④ Roll the windows down.

Figure 2-12. Truck prepared (Continued)

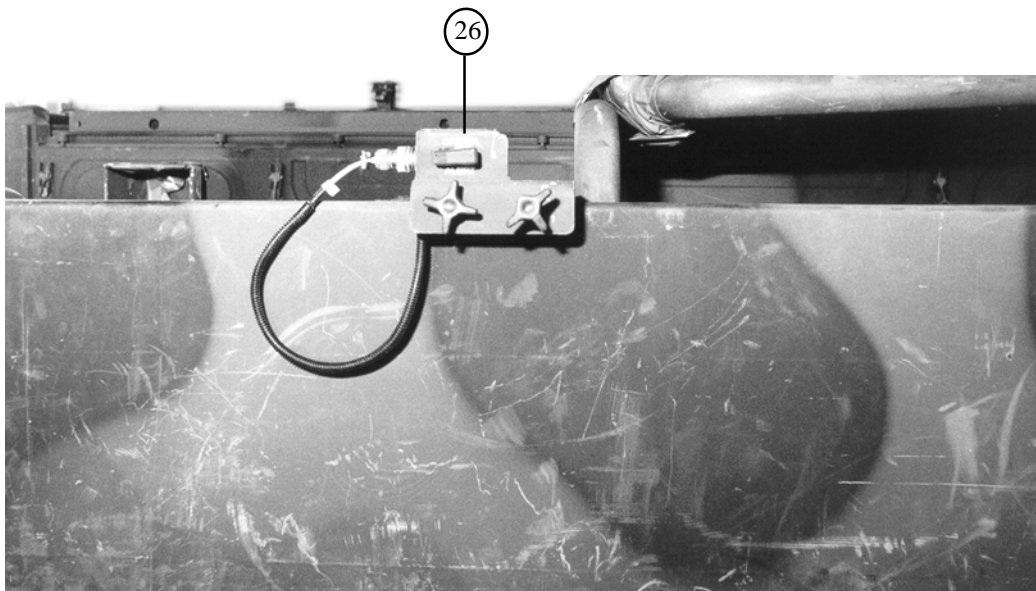
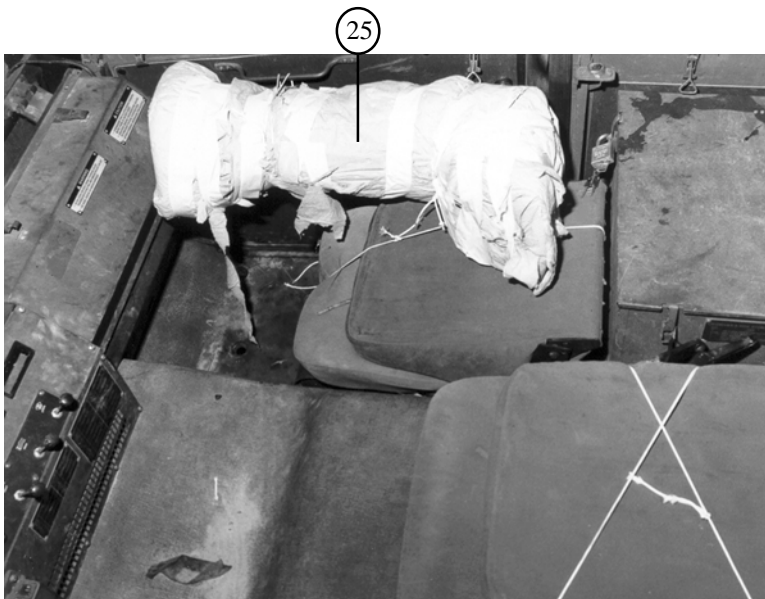

- ②5 Remove the air intake stack. Wrap it with cellulose wadding and stow in the cab.
- ②6 Remove the driver alert switch and stow in the cab. Tape the electrical connection.
- ②7 Remove the sunvisors and stow in the cab. (Not shown)

Figure 2-12. Truck prepared (Continued)

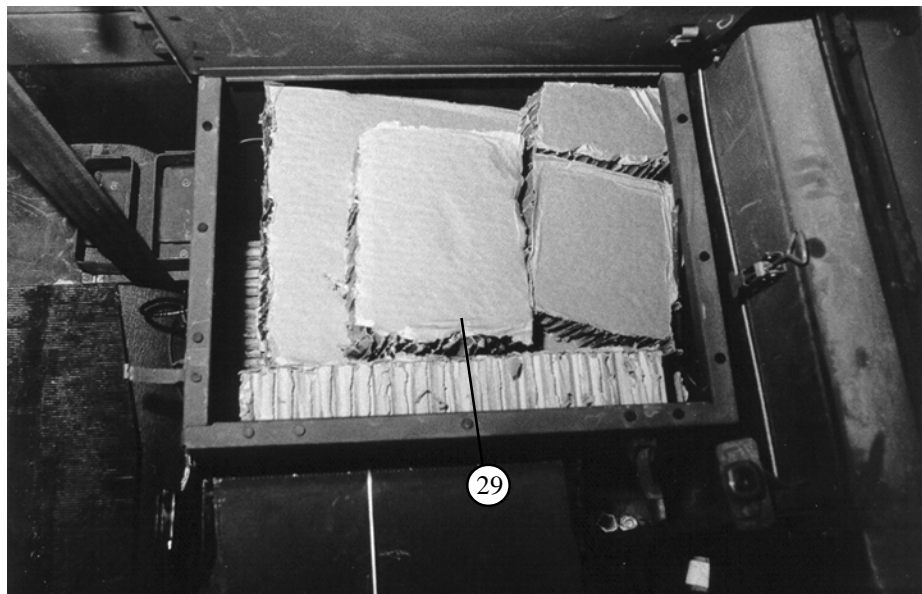
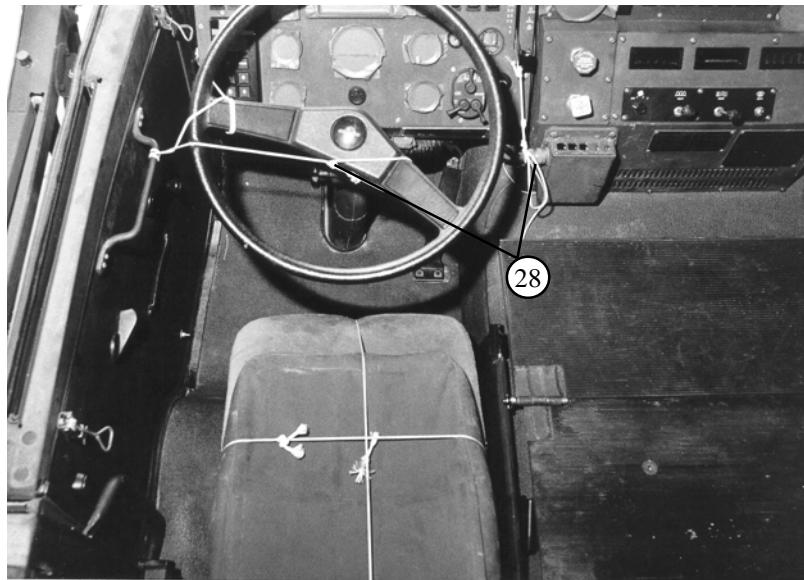

- ②⑧ Secure the steering wheel and hand throttle with type III nylon cord.
- ②⑨ Fill the driver and passenger storage boxes with honeycomb.

Figure 2-12. Truck prepared (Continued)

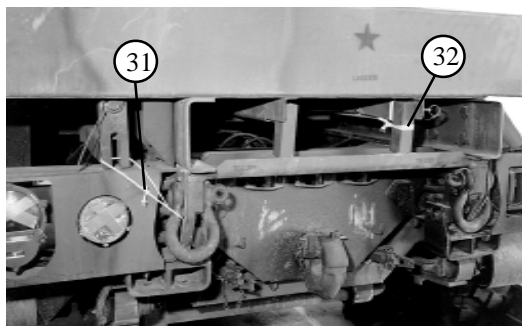
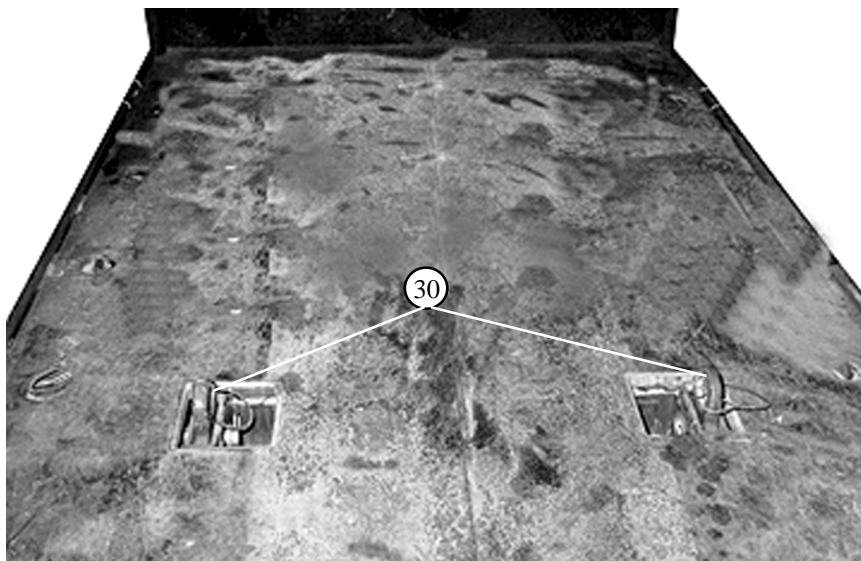

- ③⑩ Safety the left and right rear lifting pins (located on the truck bed near the rear with cover over them) with type III nylon cord. Route the type III nylon cord through the safety pin pull ring and around the safety pin. Stow the covers in the cab.
- ③⑪ Secure the ladder in place with a length of 1/2 -inch tubular nylon webbing.
- ③⑫ Secure the tow bar on the left side of the truck with a piece of type III nylon cord to the top left rear tie-down point.

Figure 2-12. Truck prepared (Continued)

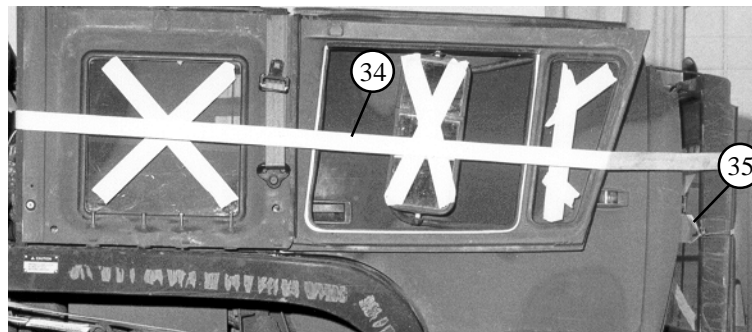
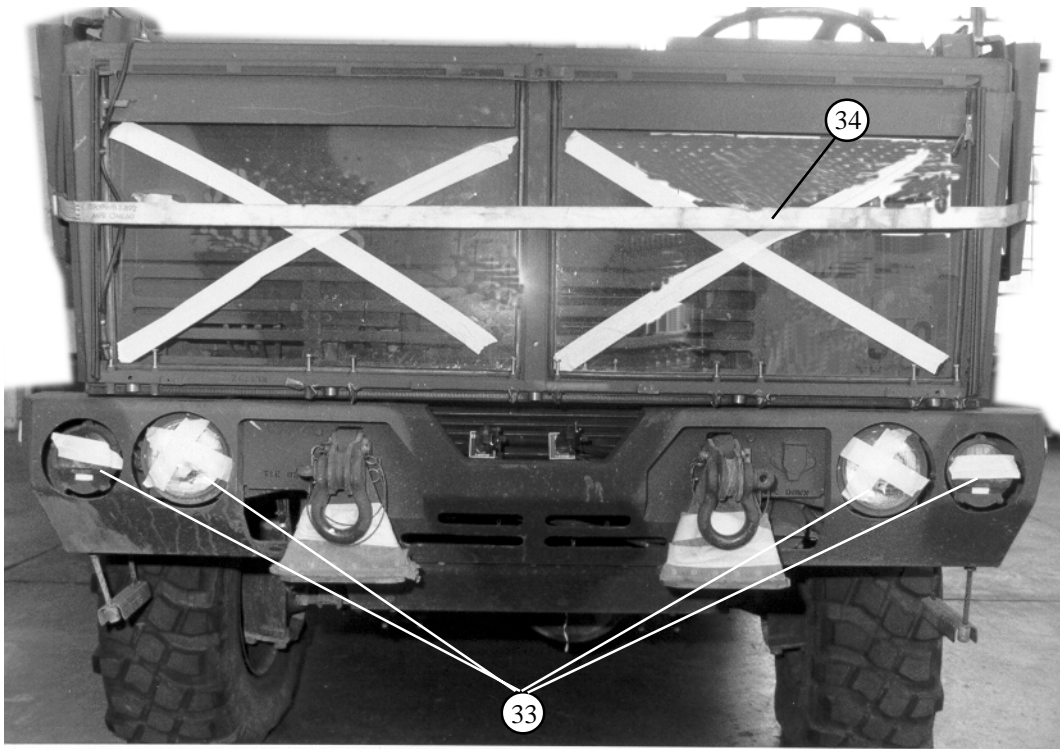

- ③③ Tape all lights, reflectors, and windows and pad mirrors with cellulose wadding and tape.
- ③④ Route a 30-foot lashing around the cab and secure with a loadbinder and D-rings in the rear of the cab. (Ensure D-rings do not come in contact with the glass).
- ③⑤ Secure the windshield to the left and right windshield stops with 1/2 -inch tubular nylon webbing.

Figure 2-12. Truck prepared (Continued)

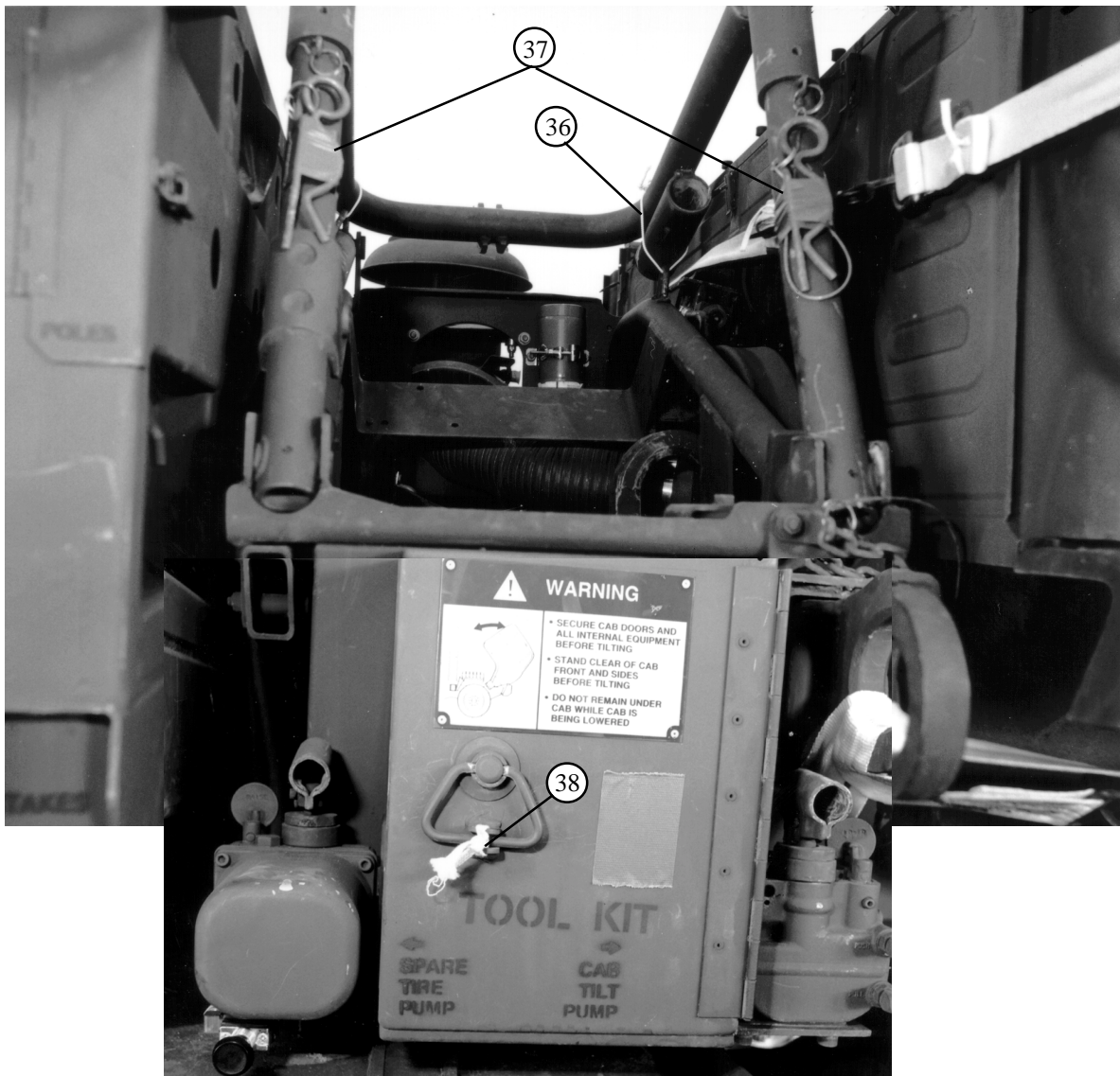

- ③⑥ Retract the spare tire carrier and secure with 1/2-inch tubular nylon webbing.
- ③⑦ Tape the chains and pins in place on the spare tire carrier.
- ③⑧ Secure the tool kit access panel with a length of type III nylon cord.

Figure 2-12. Truck prepared (Continued)

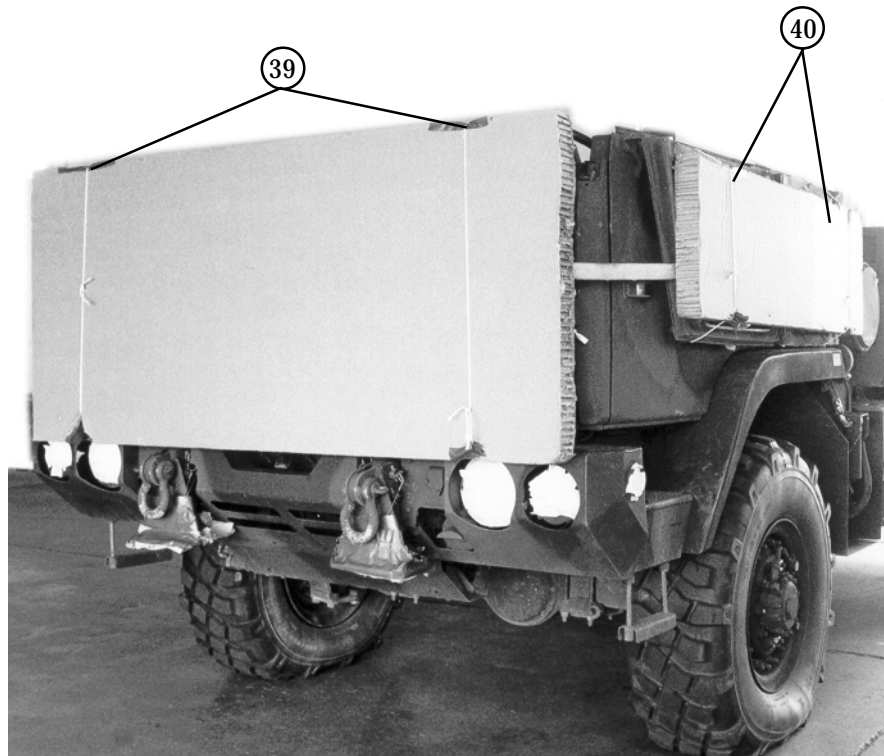

- ③⑨ Place a 36- by 80-inch piece of honeycomb on the windshield. Secure it with two lengths of type III nylon cord.
- ④⑩ Place one 18- by 60-inch piece of honeycomb on the left side window and one piece on the right side window. Secure each with two lengths of type III nylon cord.

Figure 2-12. Truck prepared (Continued)

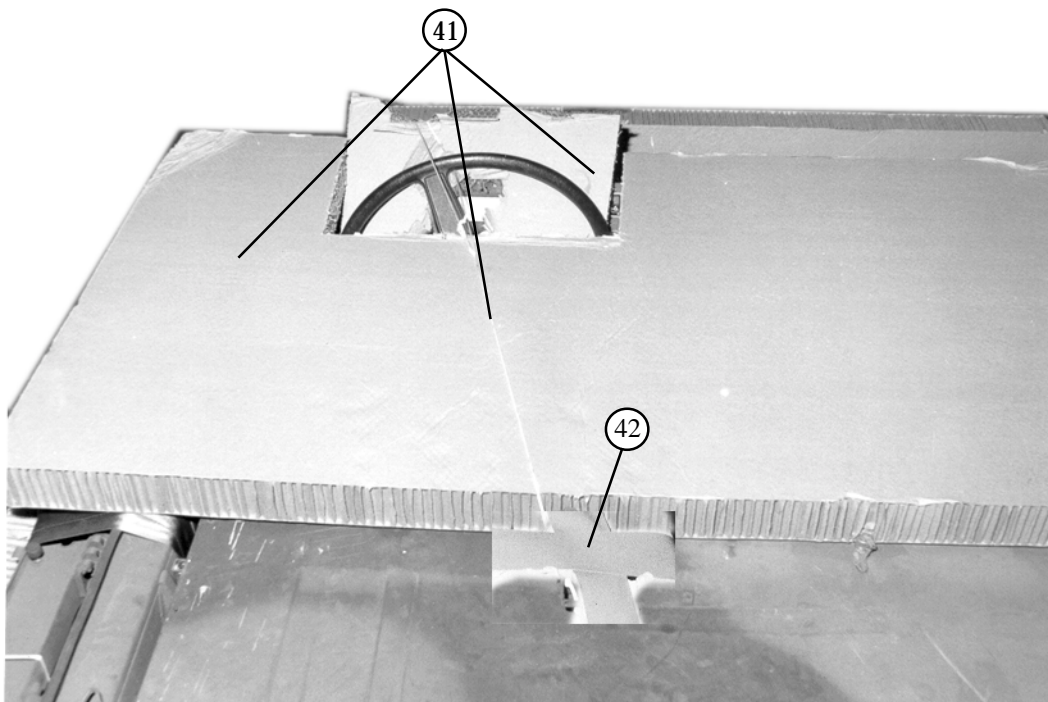

- ④① Place a 36- by 96-inch piece of honeycomb over the driver's compartment. Cut out a section (approximately 12- by 21-inches) for the steering wheel and place it over the instrumentation panel in the cab. Secure both pieces with type III nylon cord.
- ④② Pad the davit holders with cellulose wadding and secure with cloth-backed tape.

Figure 2-12. Truck prepared (Continued)

Note: Hoses that will interfere with the attaching of the suspension slings should be tied back.

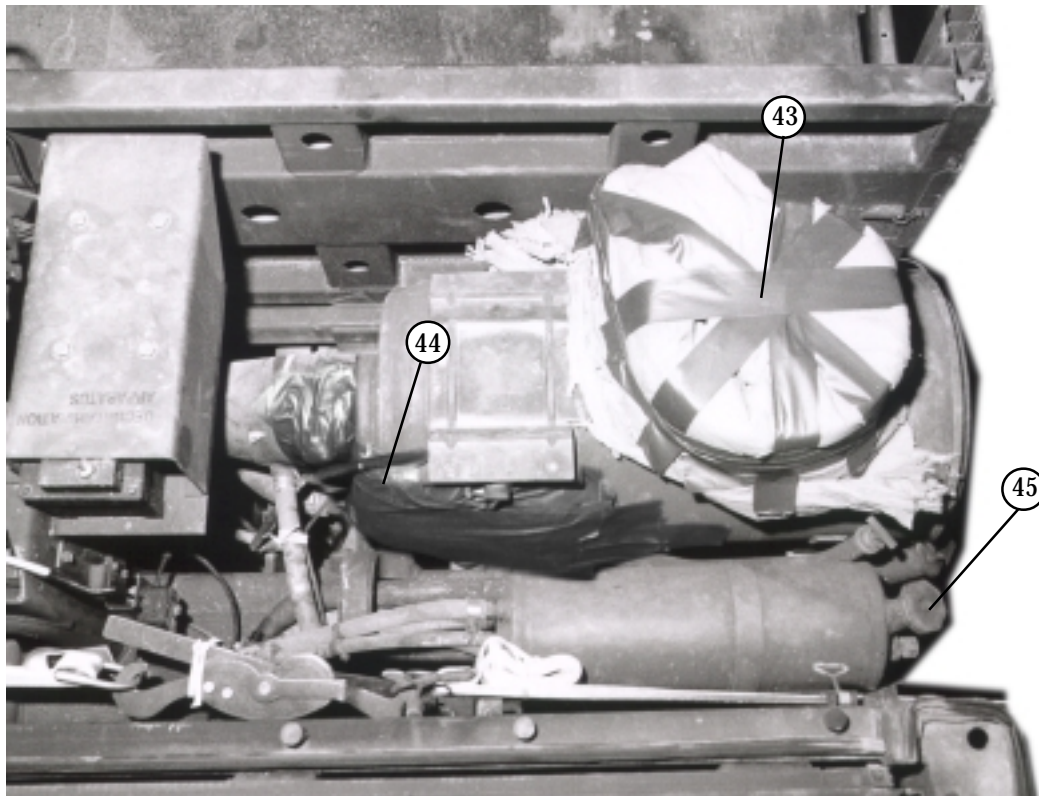

- ④③ Wrap the air intake fitting with cellulose wadding and secure with cloth-backed tape. Secure the end hose out of the way with type III nylon cord.
- ④④ Pad the lower air intake fitting with felt and secure with cloth-backed tape.
- ④⑤ Ensure the radiator pressure cap is secure.

Figure 2-12. Truck prepared (Continued)

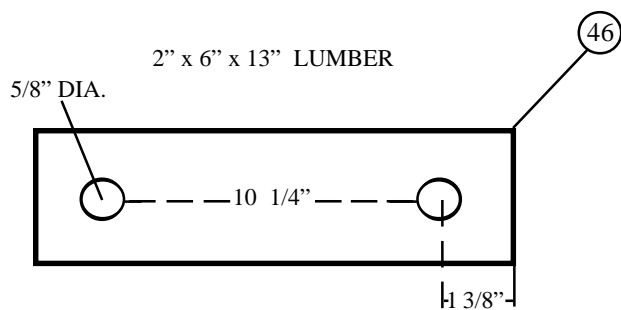

- ④6 Cut ten 2- by 6- by 13-inch pieces of lumber. Drill two 5/8-inch diameter holes 1 3/8-inches from the edge, with a 10 1/4-inch center to center hole measurement in each piece of lumber.
- ④7 Bolt five 2- by 6- by 13-inch pieces of lumber to the left and right side frame pads using two 1/2- by 10-inch bolts on each side.

Figure 2-12. Truck prepared (Continued)

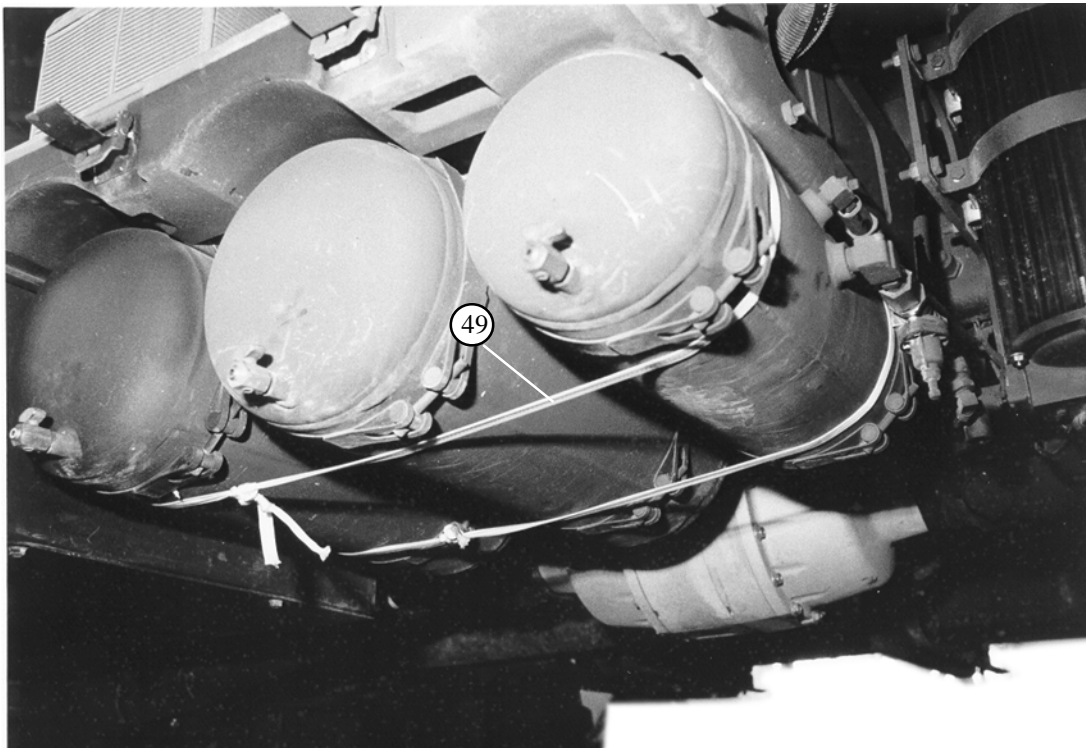
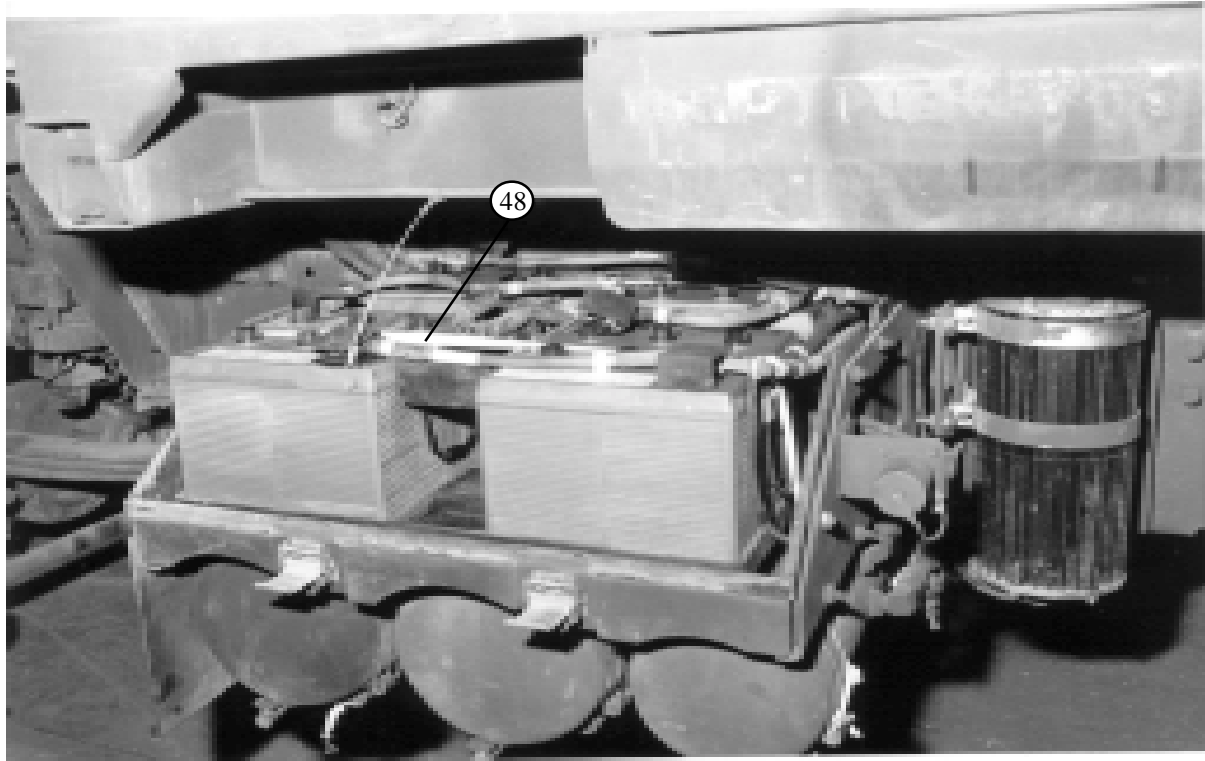

- ④8 Remove the battery box cover and secure the batteries in place with two lengths of 1/2-inch tubular nylon webbing.
- ④9 Run the nylon webbing over the batteries down through the battery box and under the air tanks.

Figure 2-12. Truck prepared (Continued)

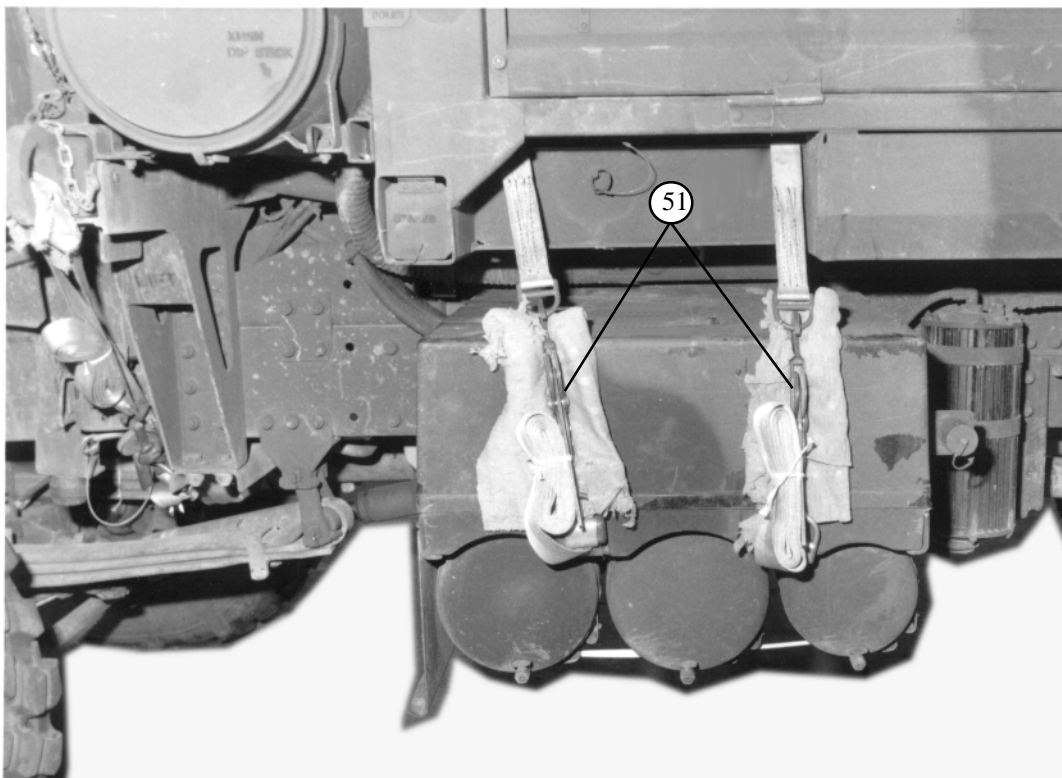
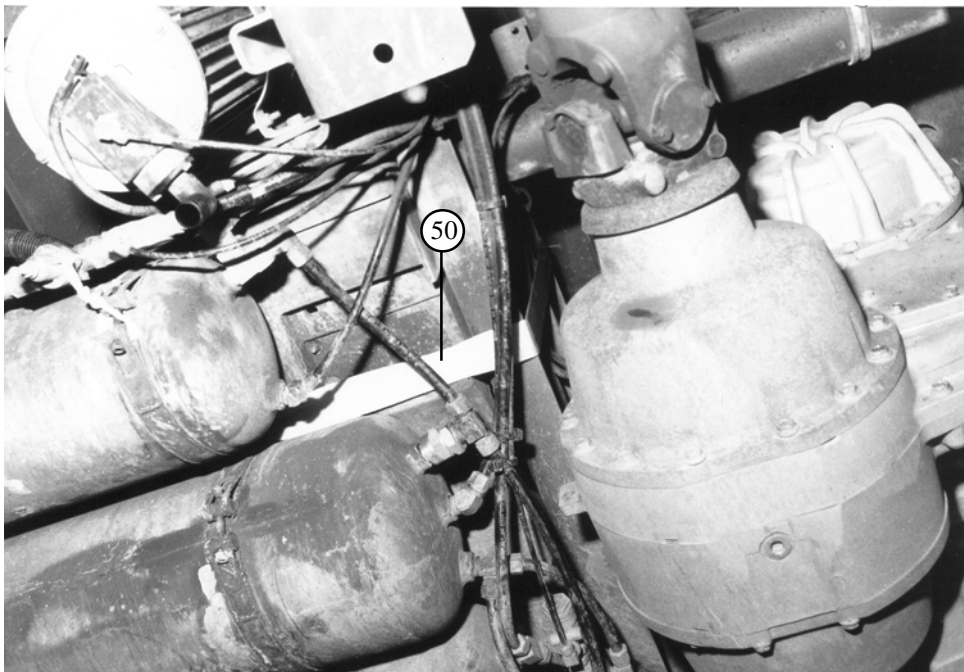

- ⑤① Replace the cover. Route two 15-foot lashings around the main frame, under the battery box, between the air tanks. Ensure hoses are not crimped.
- ⑤① Secure with D-ring and loadbinder on top of battery box. Pad with felt or cellulose wadding.

Figure 2-12. Truck prepared (Continued)

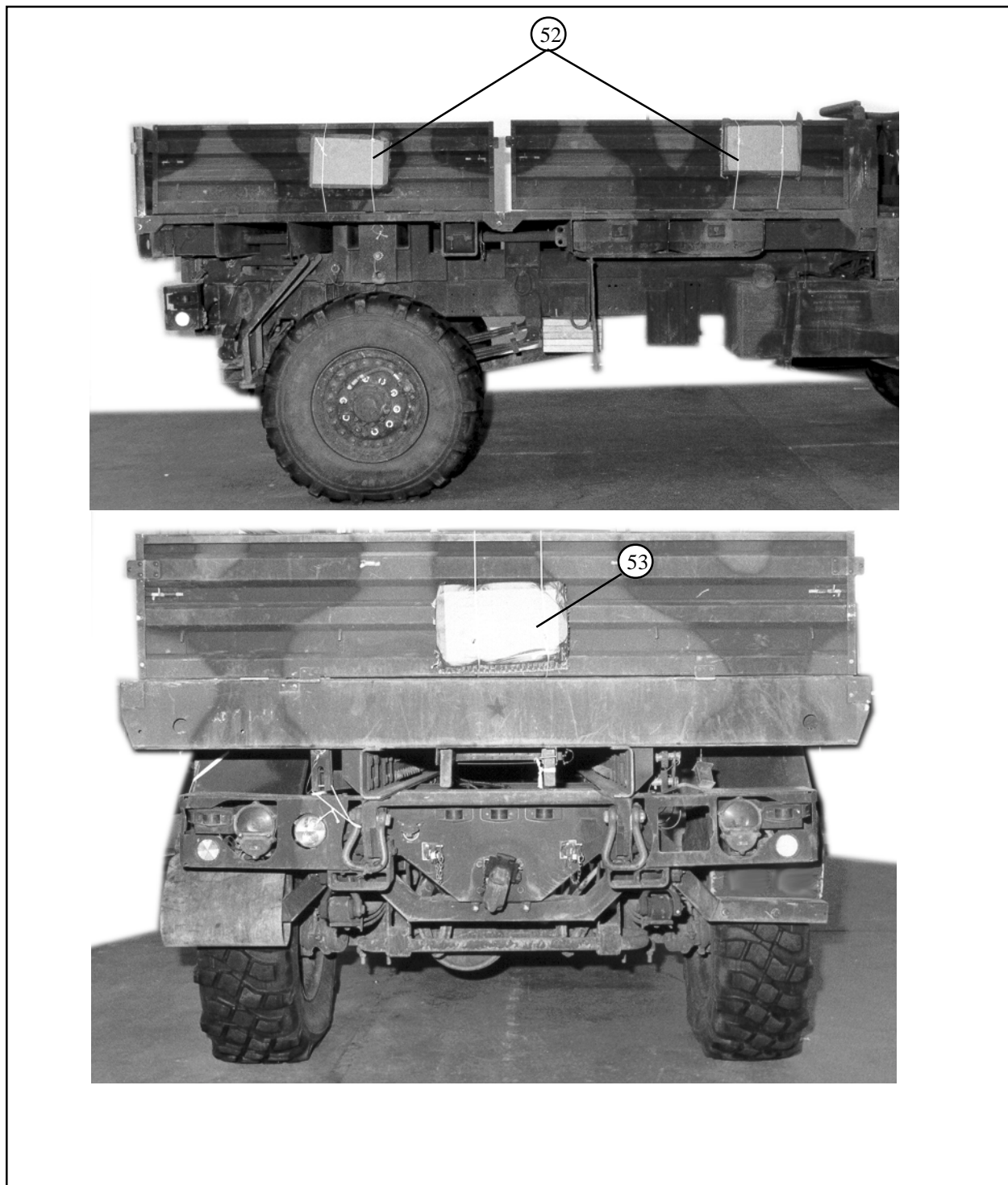

- ⑤② Raise the side panels and place an 11- by 16-inch piece of honeycomb on each contact point. Position the pieces on the front panels where they will come in contact with the fuel tank and battery box. Place the pieces on the rear panels where they will come in contact with the tires. Secure the honeycomb in place with type III nylon cord.
- ⑤③ Raise the tailgate and place an 11- by 16-inch piece of honeycomb on the center of the tailgate. Secure the honeycomb in place with type III nylon cord..

Figure 2-12. Truck prepared (Continued)

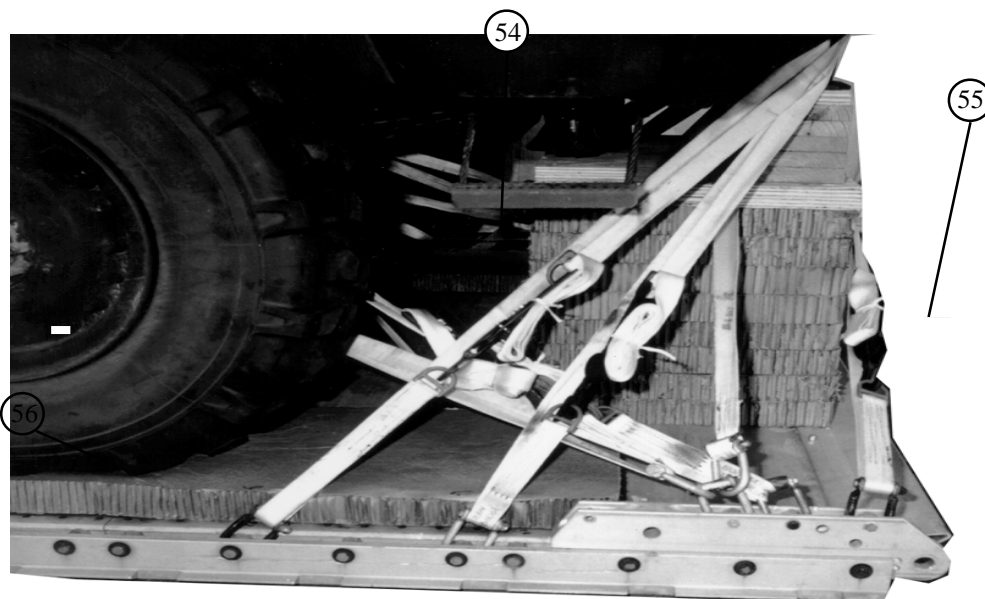
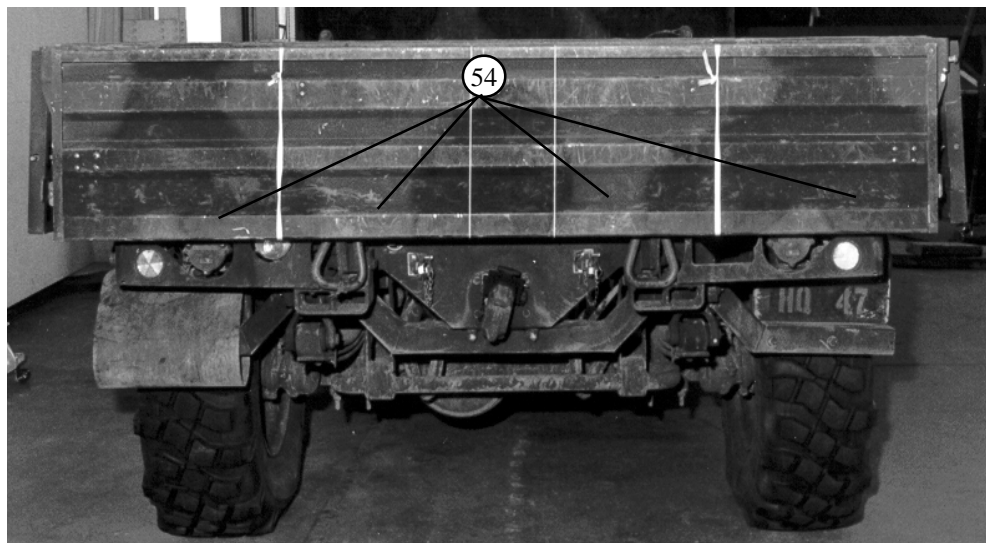

- ⑤④ Secure the side panels and tailgate down using 1/2-inch tubular nylon webbing. Tie to convenient locations on the truck.
- ⑤⑤ Using 1/2-inch tubular nylon webbing, tie the corners of the rear side panels and tailgate together. Tie the front of the forward side to convenient locations on the truck.
- ⑤⑥ Tie the mud flaps up with type III nylon cord.

Note: Steps 54 and 55 ties must be secured. No slippage of the ties is allowed. If the ties are not secure, damage may occur.

Figure 2-12. Truck prepared (Continued)

2-6. Stowing Basic Load

Basic accompanying load consists of the roof, spare tire, tire strap, davit, cargo/troop carrier cover, bows, cargo/troop carrier cover poles, bed stakes, seat bars, seats and side rails. Stow the vehicle parts as shown in *Figure 2-13*.

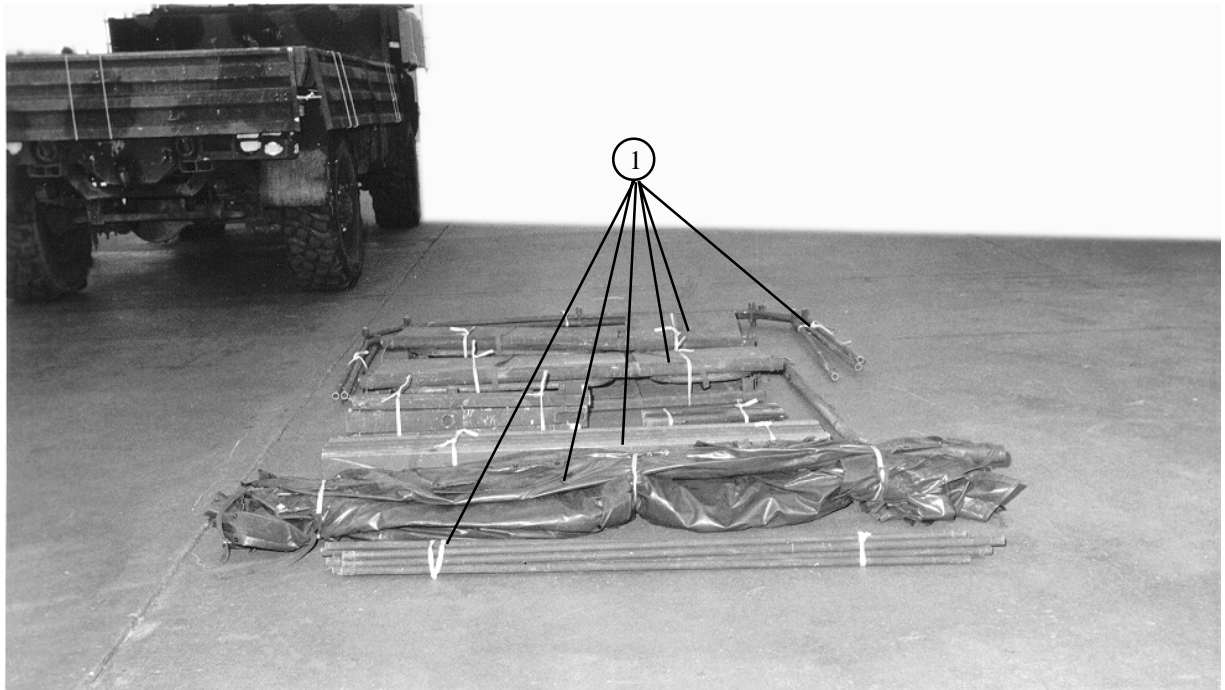

- ① Tie each like item together using 1/2-inch tubular nylon webbing, except the seats. They will be tied into two sets of two seats each.

Figure 2-13. Basic load stowed

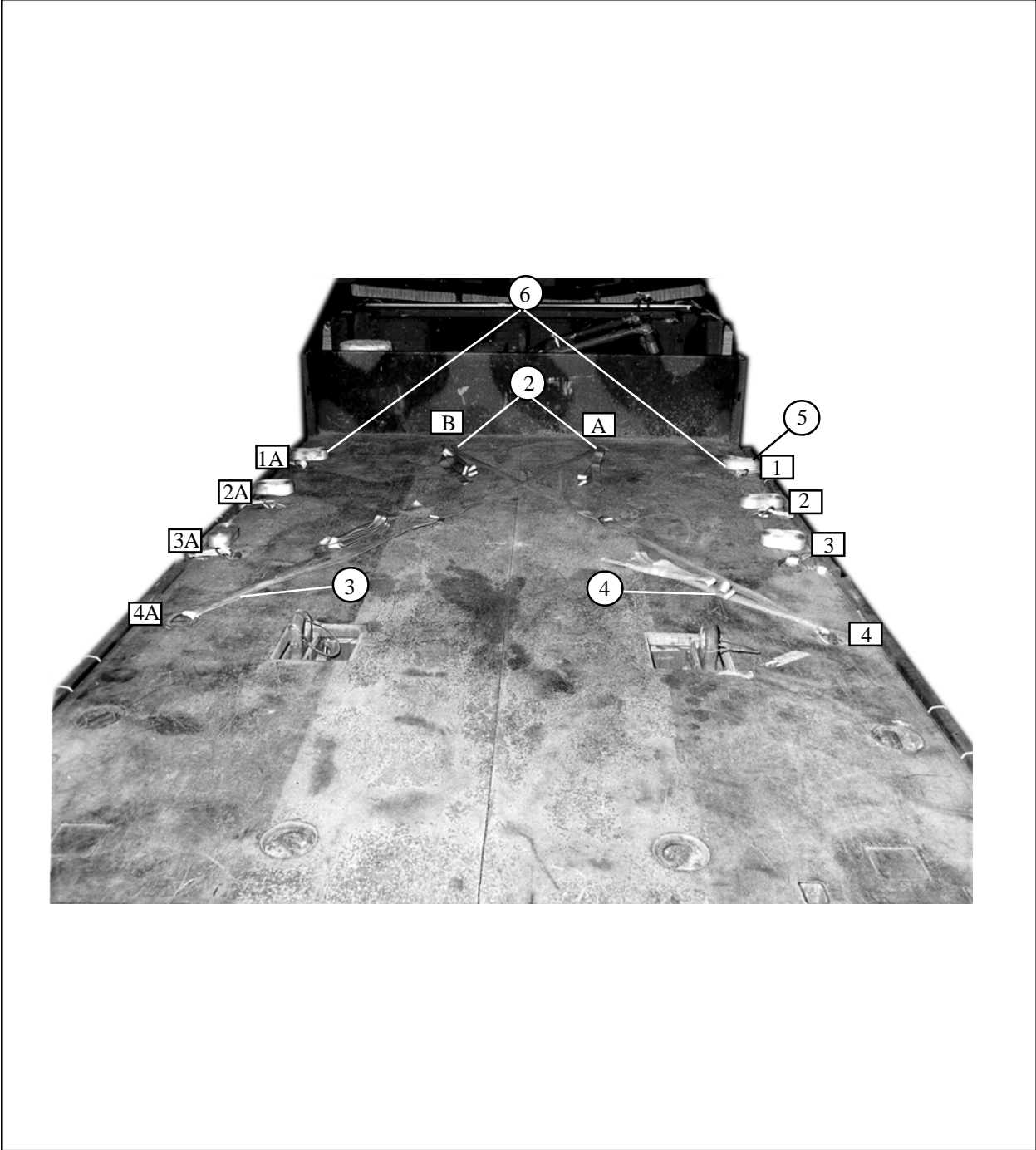

- ② Starting at the front of the truck bed, label the right side truck bed tiedown rings 1 through 4 and the left side 1A through 4A. Label the front center truck rings as A and B.
- ③ Route a 30-foot lashing from bed ring A to 4A .
- ④ Route a 30-foot lashing from bed ring B to 4 .
- ⑤ Route a 15-foot lashing through the truck bed tiedown ring 1, and through it's own D-ring. Lay it to the vehicle side or roll it up and lay it to the side.
- ⑥ Repeat for truck bed tiedown rings 2, 3, 1A, 2A and 3A.

Figure 2-13. Basic load stowed (Continued)

NOTE: Before positioning roof, make sure that all tiedown rings are laying to the outside of the truck bed.



- ⑦ Position the roof upside down and centered between truck bed tiedown rings 1, 2, 3, 1A, 2A, and 3A, with the lights facing the rear of the vehicle.

Figure 2-13. Basic load stowed (Continued)

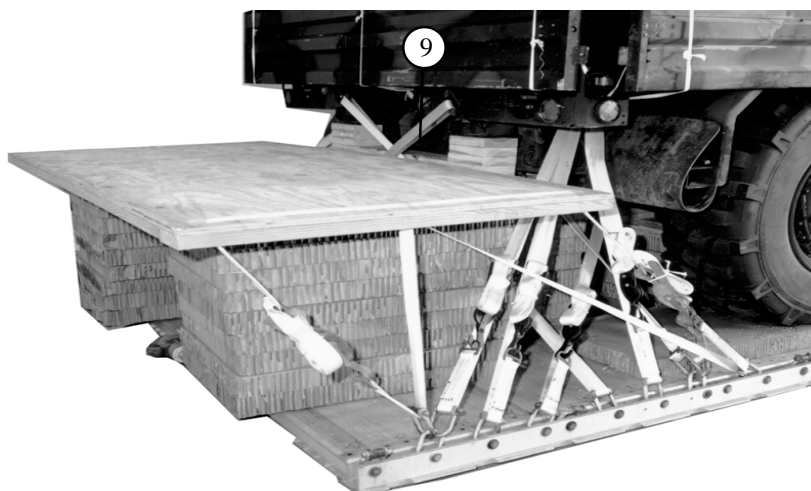

- ⑧ Roll and tape the tire strap. Secure it in the spare tire using 1/2-inch tubular nylon webbing.
- ⑨ Position the spare tire in the center of the roof.

Figure 2-13. Basic load stowed (Continued)

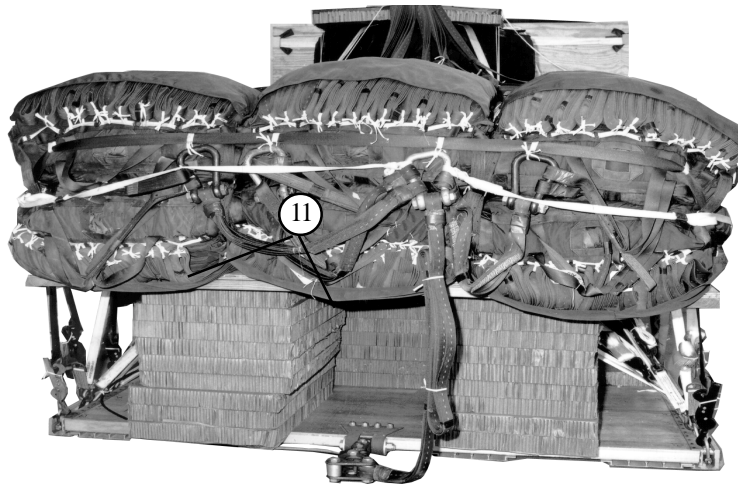
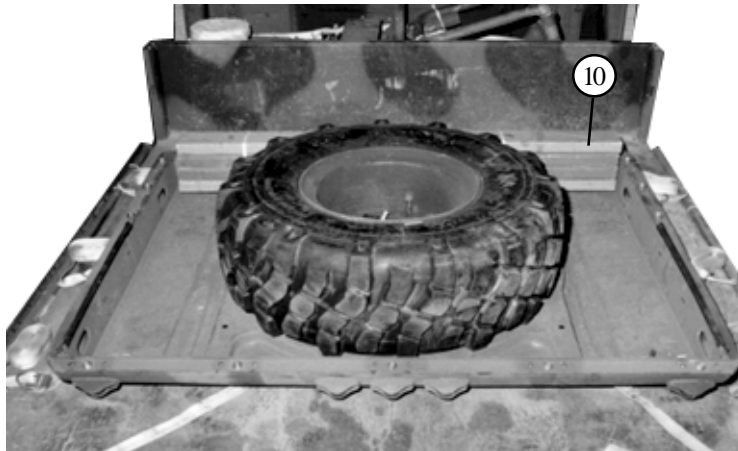

- ⑩ Position the side rails inside the roof in front of the spare tire.
- ⑪ Position the davit to the rear of the spare tire.

Figure 2-13. Basic load stowed (Continued)

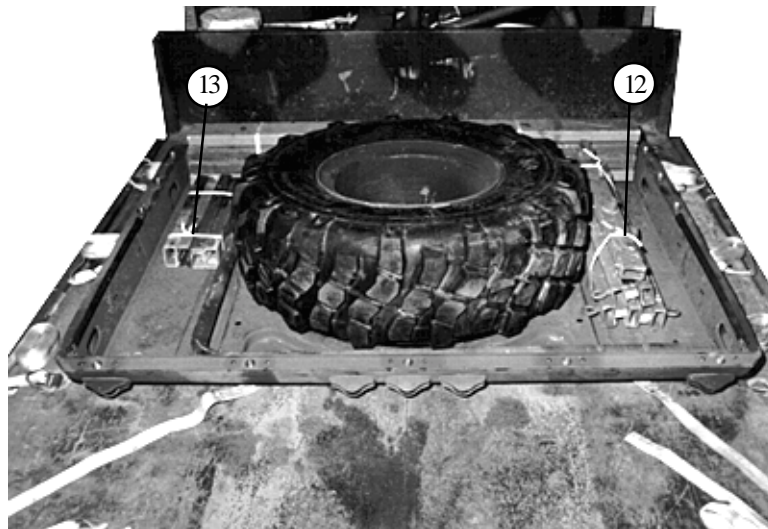

- ⑫ Place the seat bars inside the roof and to the right of the spare tire.
- ⑬ Place the bed stakes inside the roof and to the left of the spare tire.
- ⑭ Place the cargo/troop carrier cover poles in the pole holder in the front of the truck bed. (Not shown)

Figure 2-13. Basic load stowed (Continued)

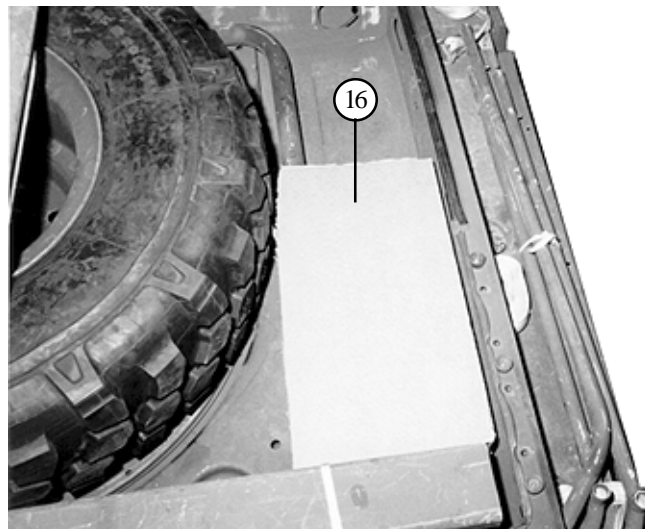
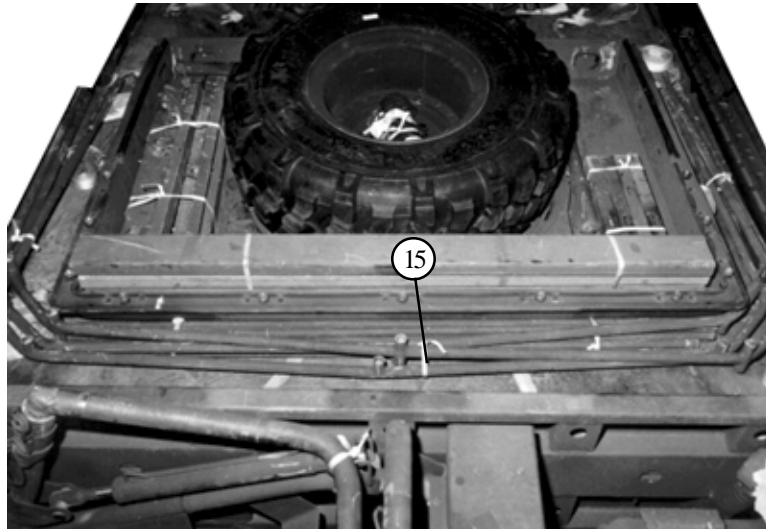

- ⑮ Position the bows in front and around the roof.
- ⑯ Position two pieces of honeycomb on the bed stakes to create a level surface.

Figure 2-13. Basic load stowed (Continued)

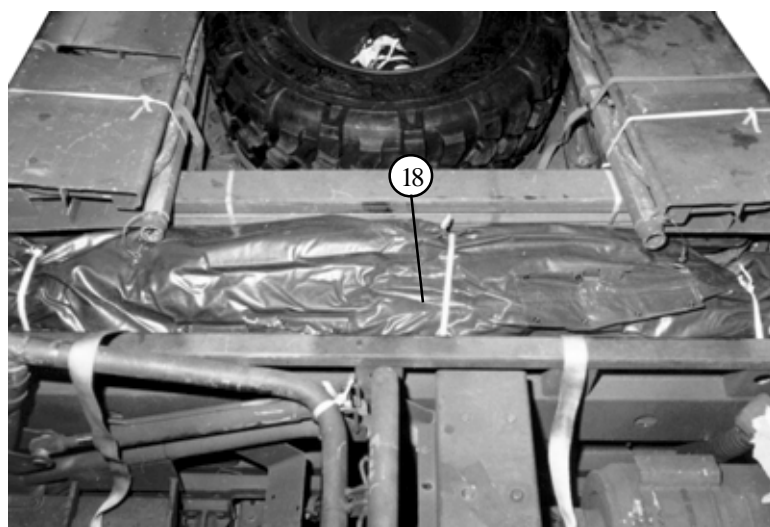
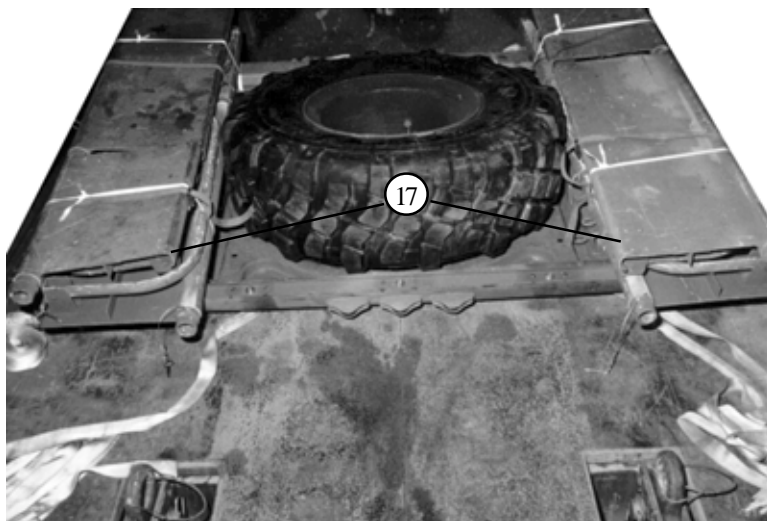

- ①⑦ Position one set of the seats to the left side and one set to the right side of the spare tire.
- ①⑧ Position the cargo/troop carrier cover to the front outside of the roof.

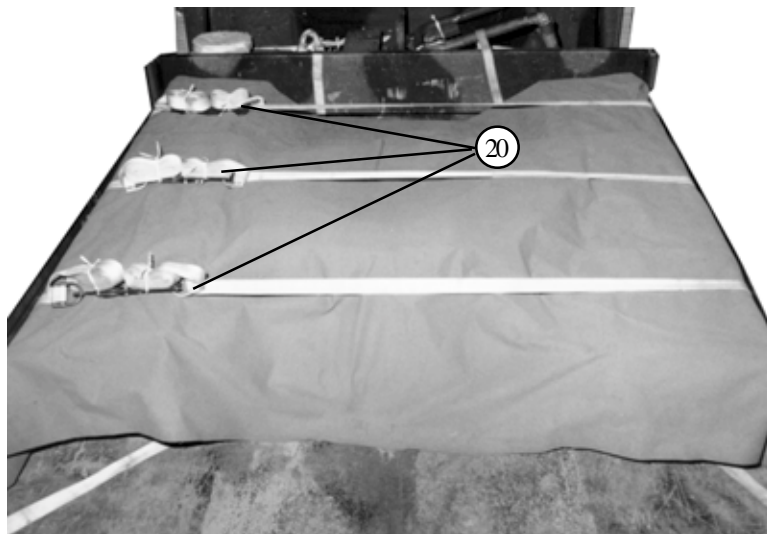
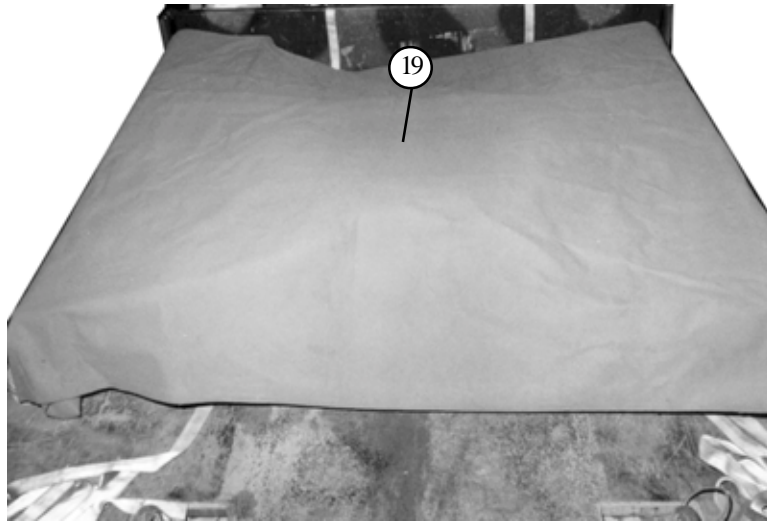

- ①⑨ Position the canvas over the basic load.
- ②⑩ Secure the lashings on top of the seats on the left side, lashing 1 to 1A, 2 to 2A, and 3 to 3A over the load. (Ensure the bows are outside the lashings to prevent bending.)

Figure 2-13. Basic load stowed (Continued)

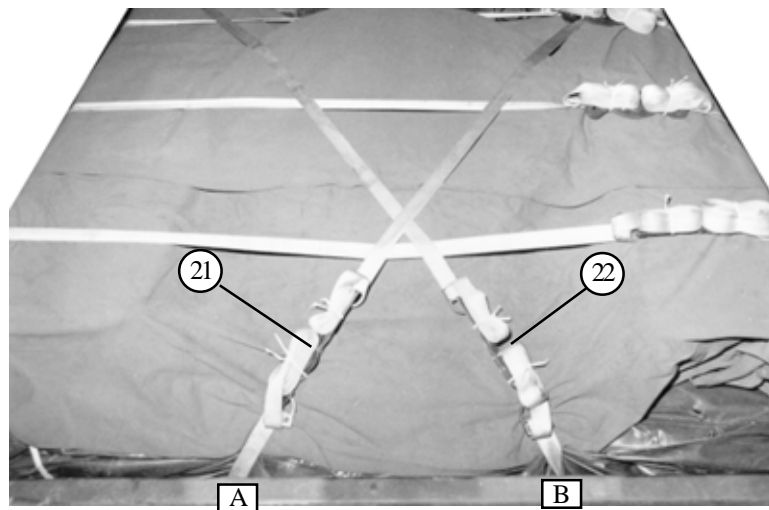

- ②1 Secure the 30-foot lashing routed from truck bed center tiedown rings A to 4A.
- ②2 Secure the 30-foot lashing routed from truck bed center tiedown rings B to 4.
- ②3 Secure the bows to 2 and 2A with 1/2-inch tubular nylon webbing. (Not shown).

Figure 2-13. Basic load stowed (Continued)

2-7. Lifting and Positioning Truck

Install lifting sling on the M1081 truck and position the truck on the platform as shown in *Figure 2-14*.

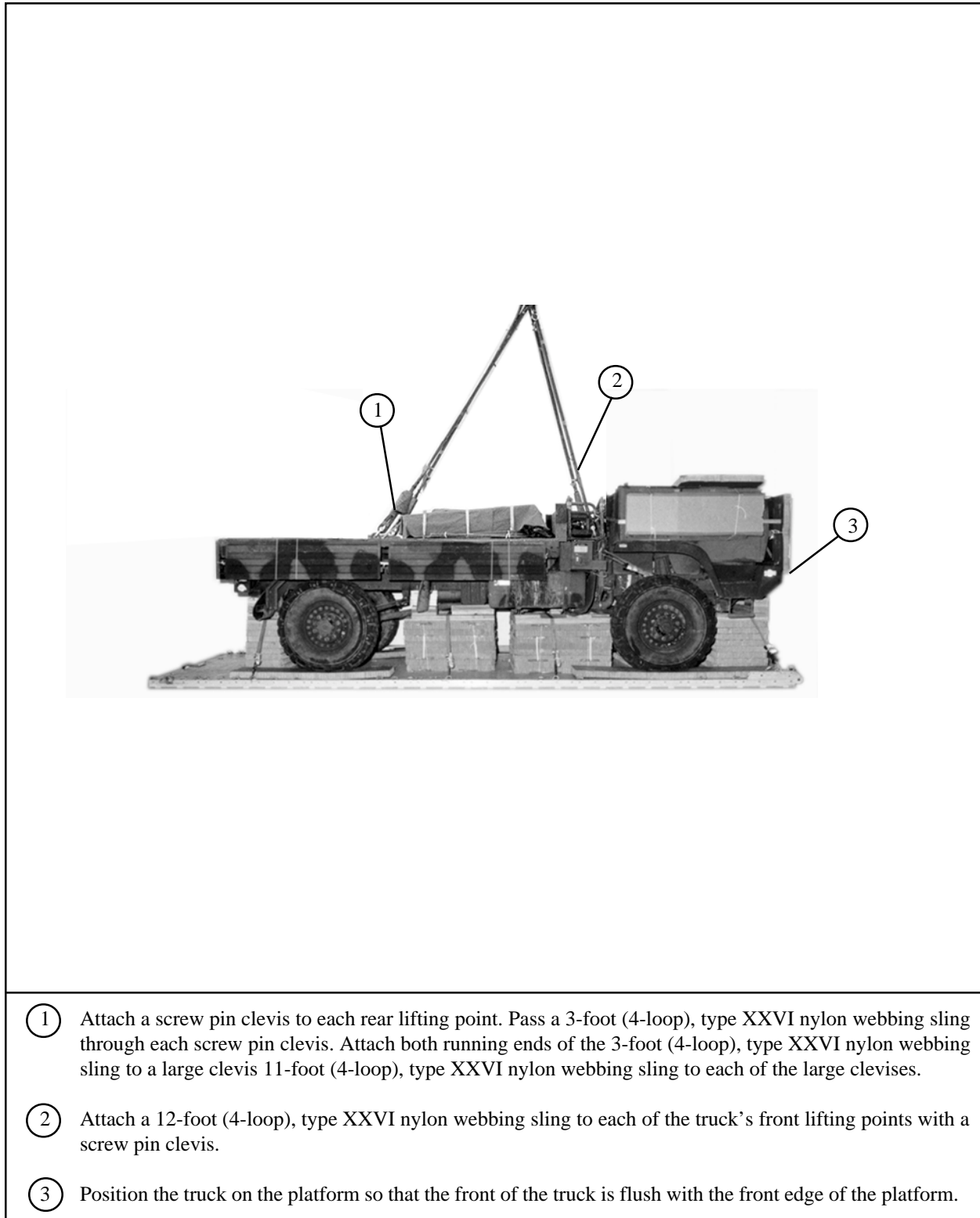
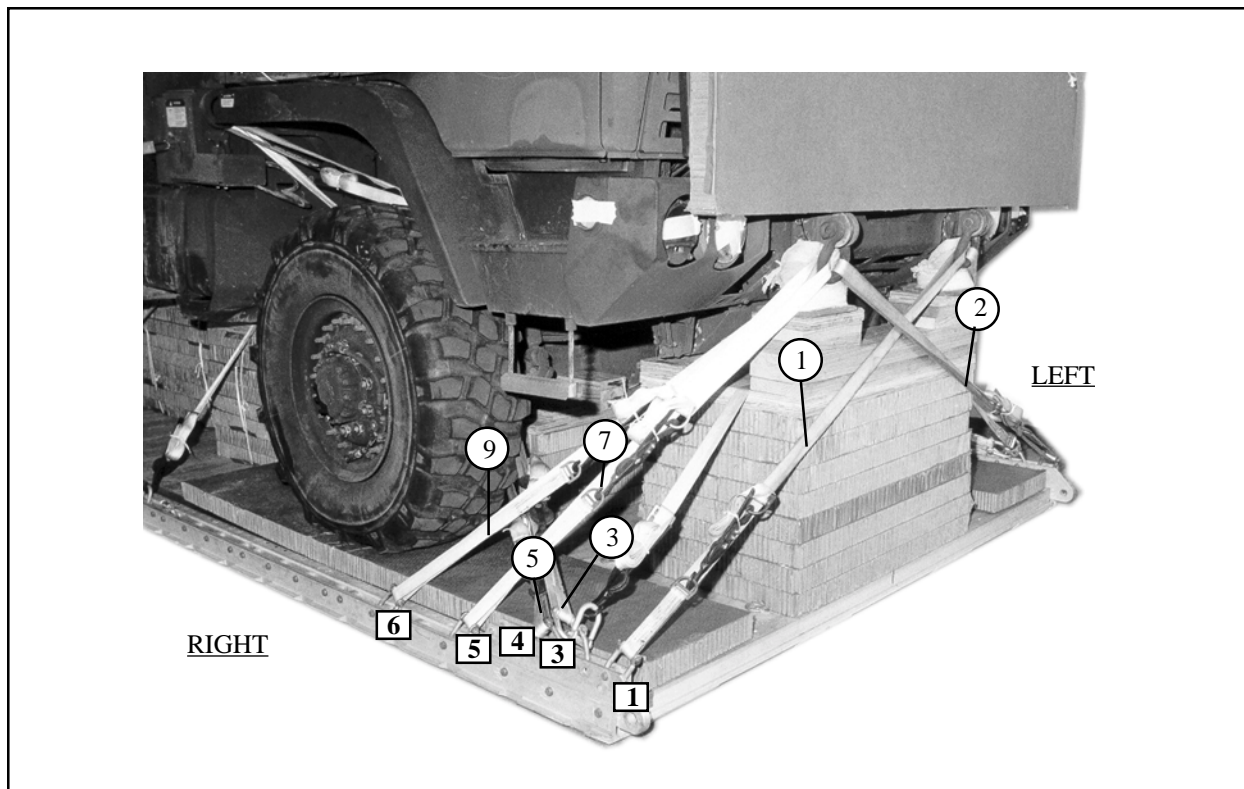

Figure 2-14. Lifting slings installed and truck positioned on the platform

2-8. Installing Lashings

Lash the truck to the platform as shown in *Figure 2-15*.
Install the lashings according to FM 10-500-2/TO 13C7-1-5.



Lashing Number	Clevis Number	Instructions
1	1	Route a 15-foot lashing through the front shackle on the left side.
2	1a	Route a 15-foot lashing through the front shackle on the right side.
3	3	Route a 15-foot lashing around the front axle, right side.
4	3a	Route a 15-foot lashing around the front axle, left side.
5	4	Route a 15-foot lashing around the front axle, right side.
6	4a	Route a 15-foot lashing around the front axle, left side.
7	5	Route a 15-foot lashing through the front shackle on the right side.
8	5a	Route a 15-foot lashing through the front shackle on the left side.
9	6	Route a 15-foot lashing through the front shackle on the right side.
10	6a	Route a 15-foot lashing through the front shackle on the left side.

Figure 2-15. Lashings installed

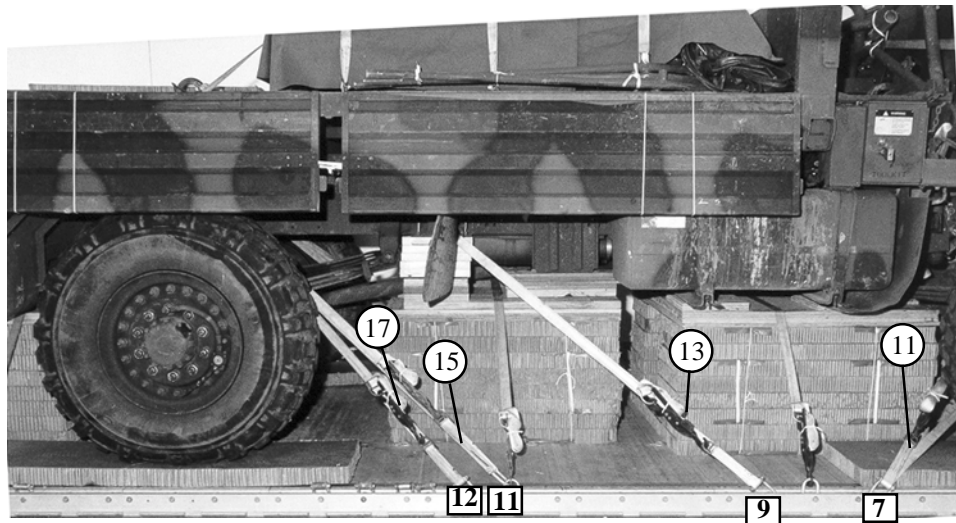

Lashing Number	Clevis Number	Instructions
11	7	Route a 15-foot lashing around the front axle, right side.
12	7a	Route a 15-foot lashing around the front axle, left side.
13	9	Route a 15-foot lashing through tiedown point #1 on the right side.
14	9a	Route a 15-foot lashing through tiedown point #1 on the left side.
15	11	Route a 15-foot lashing through tiedown point #3 on the right side.
16	11a	Route a 15-foot lashing through tiedown point #3 on the left side.
17	12	Route a 15-foot lashing through tiedown point #3 on the right side.
18	12a	Route a 15-foot lashing through tiedown point #3 on the left side.

Figure 2-15. Lashings installed (Continued)

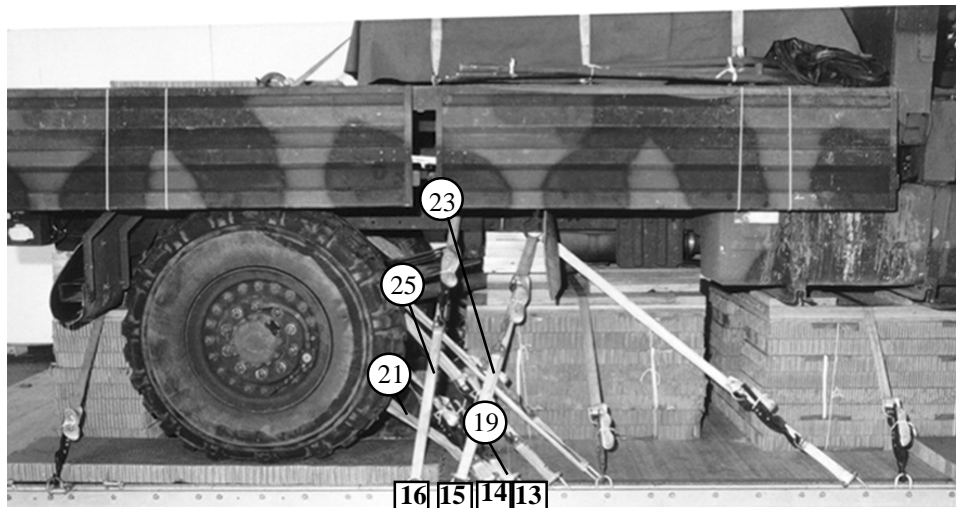

Lashing Number	Clevis Number	Instructions
19	13	Route a 15-foot lashing around the rear axle, right side.
20	13a	Route a 15-foot lashing around the rear axle, left side.
21	14	Route a 15-foot lashing around the rear axle, right side.
22	14a	Route a 15-foot lashing around the rear axle, left side.
23	15	Route a 15-foot lashing through tiedown point #1 on the right side.
24	15a	Route a 15-foot lashing through tiedown point #1 on the left side.
25	16	Route a 15-foot lashing through tiedown point #2 on the right side.
26	16a	Route a 15-foot lashing through tiedown point #2 on the left side.

Figure 2-15. Lashings installed (Continued)

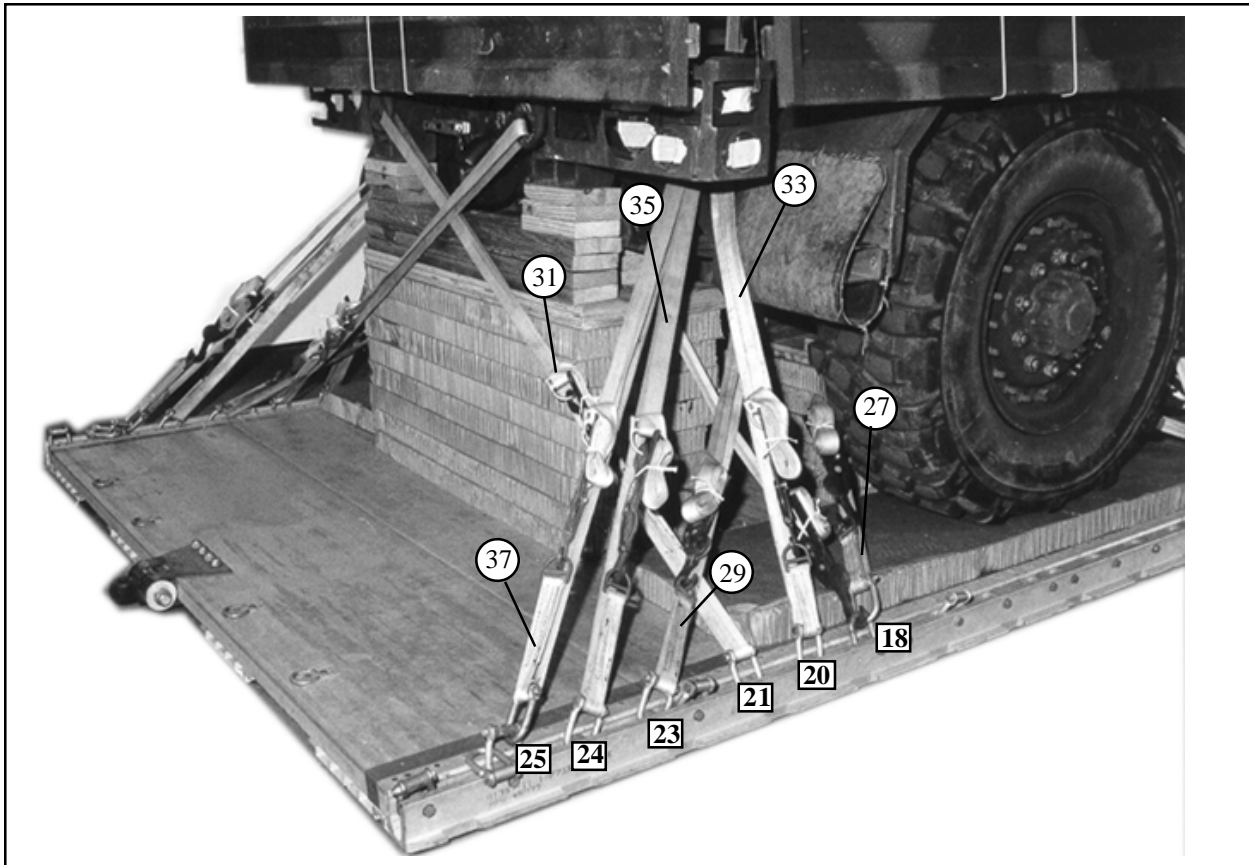

Lashing Number	Clevis Number	Instructions
27	18	Route a 15-foot lashing around the rear axle on the right side.
28	18a	Route a 15-foot lashing around the rear axle on the left side.
29	23	Route a 15-foot lashing around the rear axle stabilizer bar on the right side.
30	23a	Route a 15-foot lashing around the rear axle stabilizer bar on the left side.
31	21	Route a 15-foot lashing through the rear shackle on the left side.
32	21a	Route a 15-foot lashing through the rear shackle on the right side.
33	20	Route a 15-foot lashing through tiedown point #4 on the right side.
34	20a	Route a 15-foot lashing through tiedown point #4 on the right side.
35	24	Route a 15-foot lashing through tiedown point #4 on the right side.
36	24a	Route a 15-foot lashing through tiedown point #4 on the left side.
37	25	Route a 15-foot lashing through tiedown point #4 on the right side.
38	25a	Route a 15-foot lashing through tiedown point #4 on the left side.

Figure 2-15. Lashings installed (Continued)

2-9. Installing and Safetying Suspension Slings

Install and safety two 11-foot (4-loop), two 3-foot (4-loop), type XXVI nylon slings and two 12-foot (4-loop), type XXVI nylon slings as shown in *Figure 2-16*.

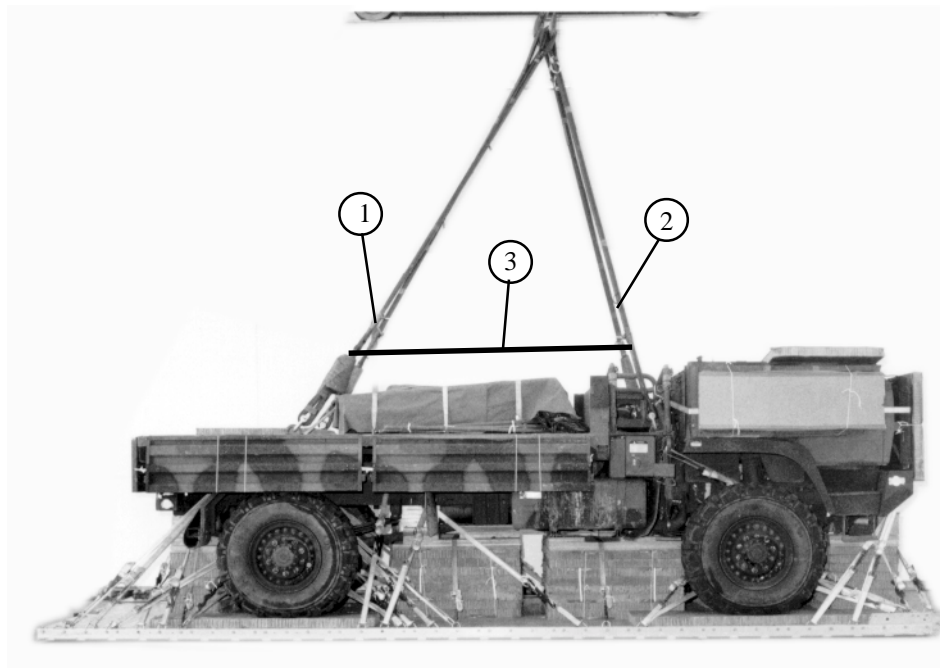

- ① Attach an 11-foot (4-loop), type XXVI sling to the rear lifting points with a screw pin clevis. Attach a 3-foot (4-loop), type XXVI sling to each of the rear slings with a 5 1/2-inch two-point link. Wrap with felt and tape the links.
- ② Attach a 12-foot (4-loop), type XXVI sling to each of the front lifting points with a screw pin clevis.
- ③ Raise the slings and install the deadman's tie according to FM 10-500-2/TO 13C7-1-5.

Figure 2-16. Suspension slings installed and safetied

2-10. Building and Positioning the Parachute Stowage Platform

Build and position the parachute stowage platform as shown in *Figure 2-17*.

Note: This drawing is not drawn to scale.

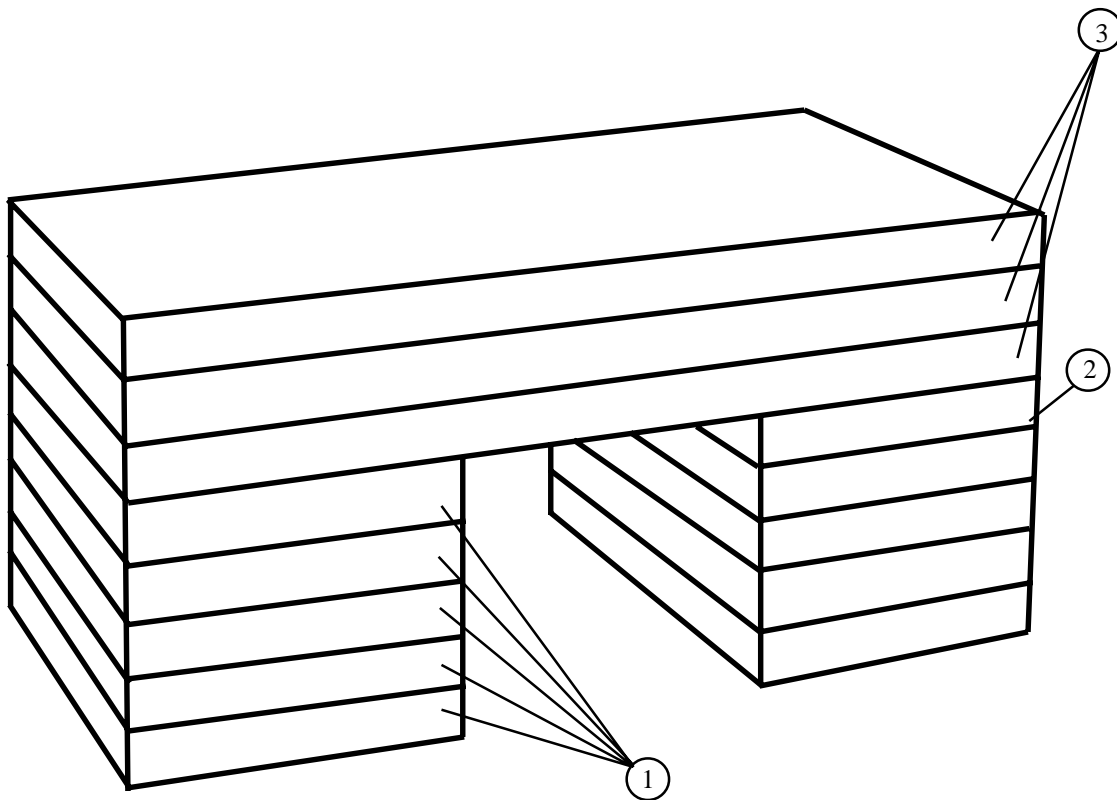

- ① Cut ten pieces of 24- by 36-inch honeycomb. Glue five layers of honeycomb together forming a stack. Repeat forming the second stack.
- ② Cut three pieces of 36- by 70-inch honeycomb. Glue honeycomb together forming a stack.
- ③ Glue one 24- by 36-inch honeycomb stack to the right side and 22 inches apart from the other honeycomb stack on the left side of the 36- by 70-inch honeycomb stack.

Figure 2-17. Cargo stowage platform positioned

Note: This drawing is not drawn to scale.

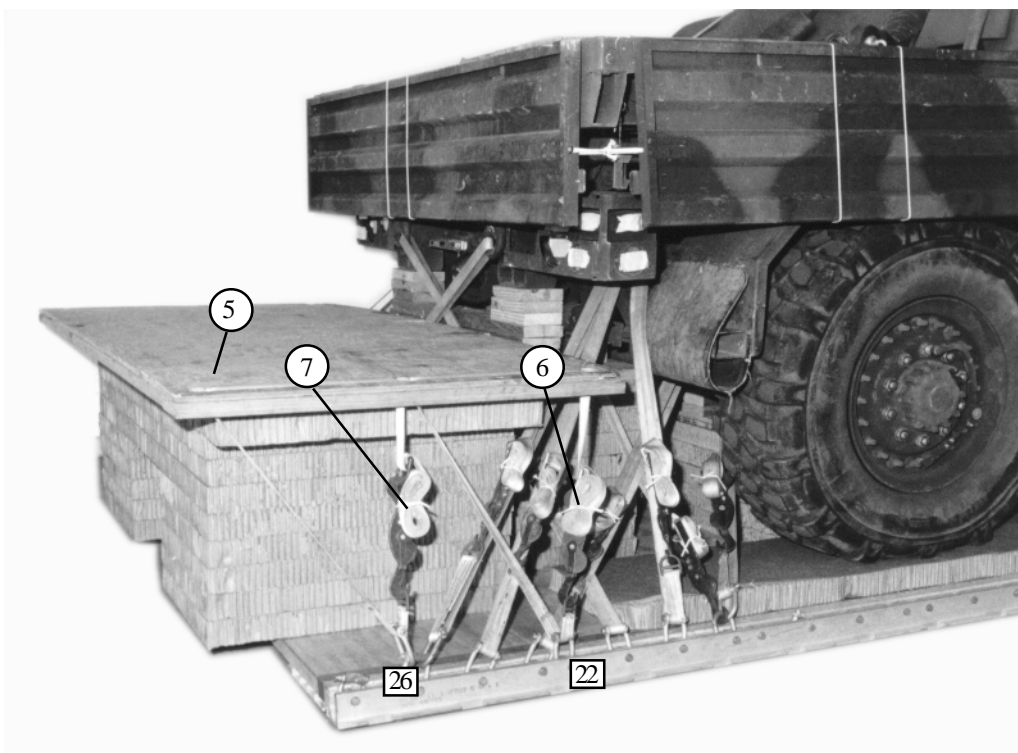
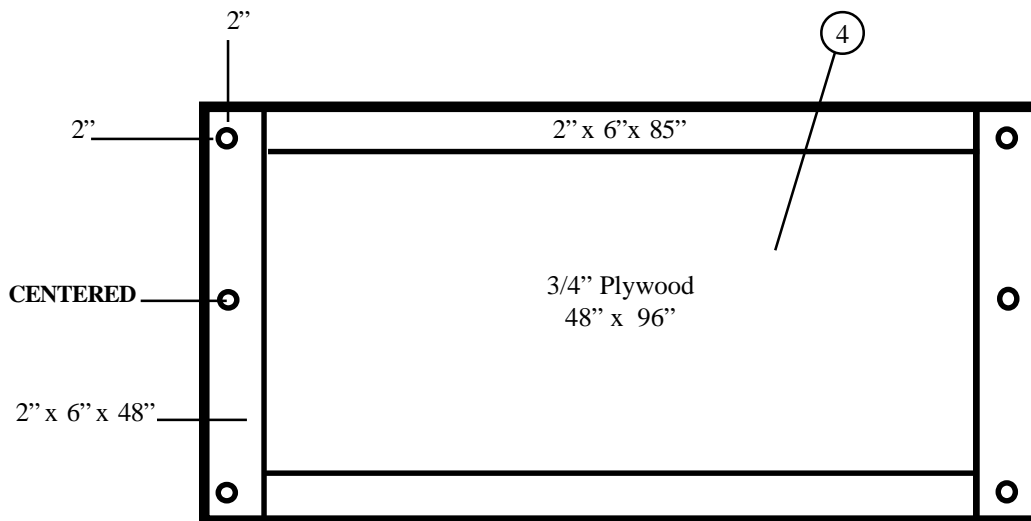

- ④ Construct a stowage platform as shown, using one sheet of 3/4-inch plywood. Glue two pieces of 36- by 84-inch honeycomb inside the stowage platform.
- ⑤ Center the stowage platform on the 36- by 70-inch honeycomb stack and flush against the lashings.
- ⑥ Route a lashing through clevis 22, through the front right hole in the stowage platform, and through the center right hole. Secure with a loadbinder. Repeat using clevis 22A for the left side.
- ⑦ Route a lashing through clevis 26, through the center right hole in the stowage platform, and through the rear right hole. Secure with a loadbinder. Repeat using clevis 26A for the left side.

Figure 2-17. Cargo stowage platform positioned (Continued)

2-11. Stowing Cargo Parachutes

Stow five G-11 cargo parachutes as shown in *Figure 2-18*.

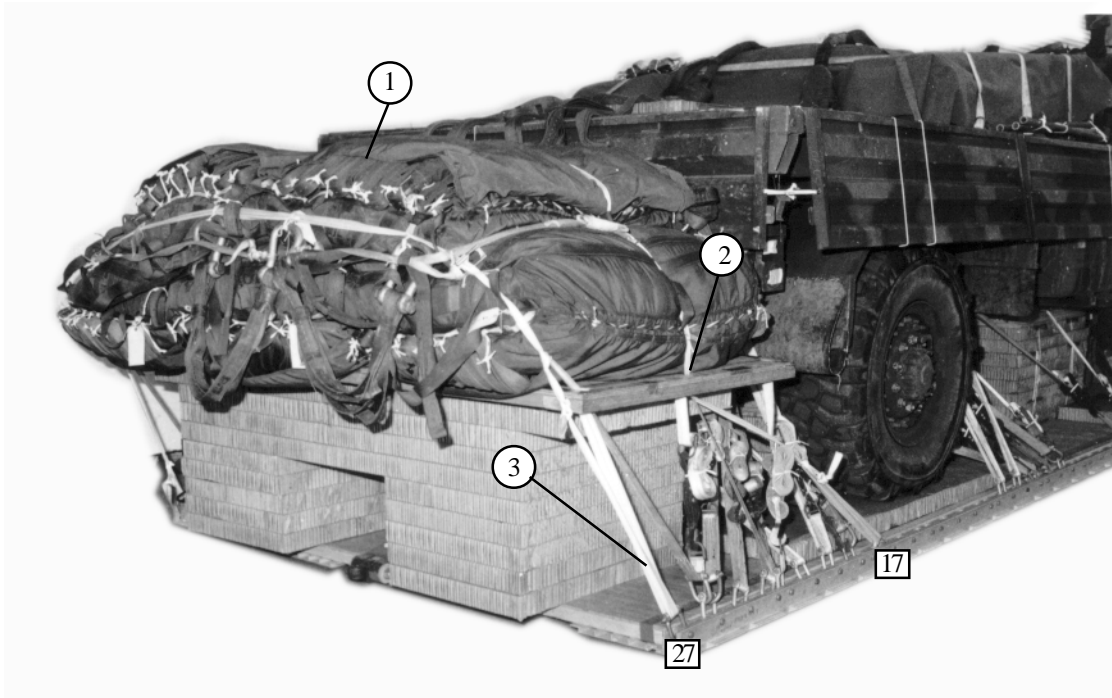

- ① Prepare, cluster and place five G-11 parachutes on the parachute stowage platform according to FM 10-500-2/TO 13C7-1-5. Install parachute restraints according to FM 10-500-2/TO 13C7-1-5.
- ② Secure the aft restraint to clevis 17 right side. Repeat for the left side using clevis 17A.
- ③ Secure the rear restraint to clevis 27 right side. Repeat for the left side using clevis 27A.

Figure 2-18. Cargo parachutes stowed

2-12. Installing Extraction System

Install the components of the extraction force transfer coupling (EFTC) according to FM 10-500-2/TO 13C7-1-5 and as shown in *Figure 2-19*.

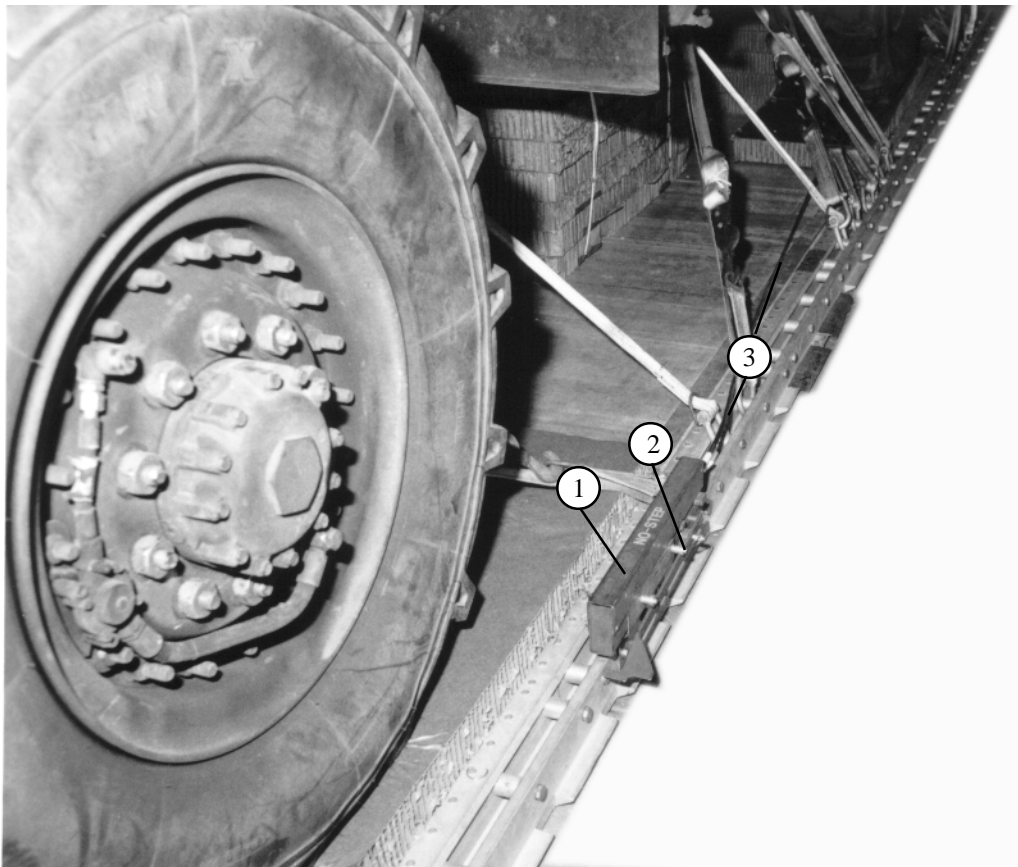

- ① Install the EFTC according to FM 10-500-2/TO 13C7-1-5.
- ② Install the EFTC mounting brackets in the rear mounting holes in the left platform rail.
- ③ Attach a 20-foot release cable to the actuator. Install the actuator in the EFTC mounting bracket.

Figure 2-19. Extraction system installed

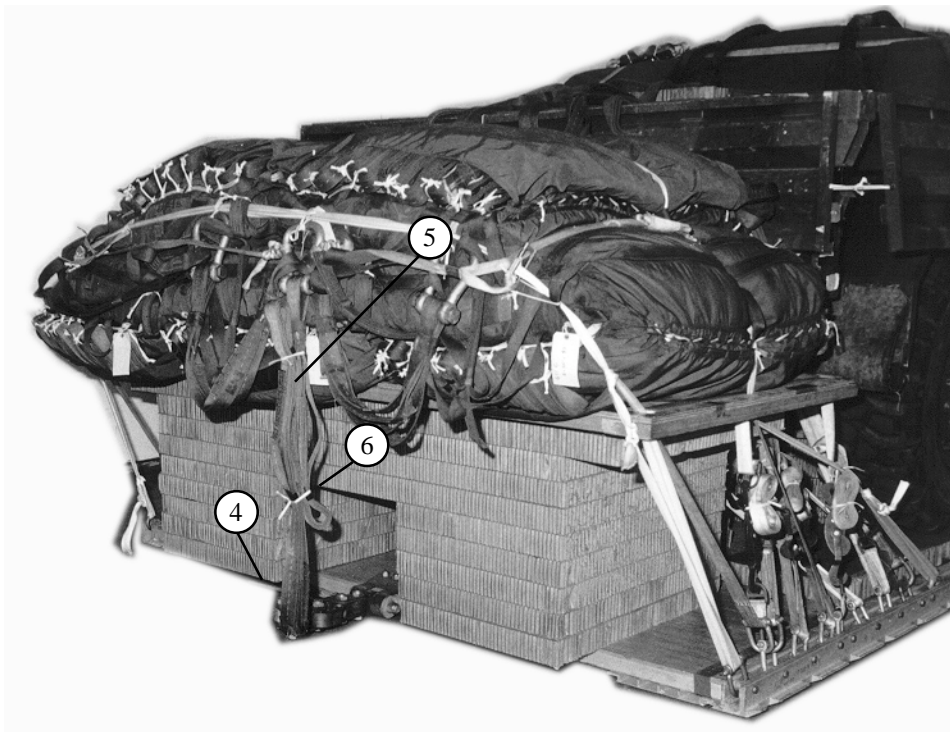

- ④ Safety the release cable with type I, 1/4-inch cotton webbing to the platform bushing or deck-rings.
- ⑤ Attach a 9-foot (2-loop), type XXXVI nylon sling, for use as a deployment line.
- ⑥ S-fold and secure the folds with type I, 1/4-inch cotton webbing according to FM 10-500-2/TO 13C7-1-5.

Figure 2-19. Extraction system installed (Continued)

2-13. Installing Release System

Install an M-2 cargo parachute release according to FM 10-500-2/TO 13C7-1-5 and as shown in *Figure 2-20*.

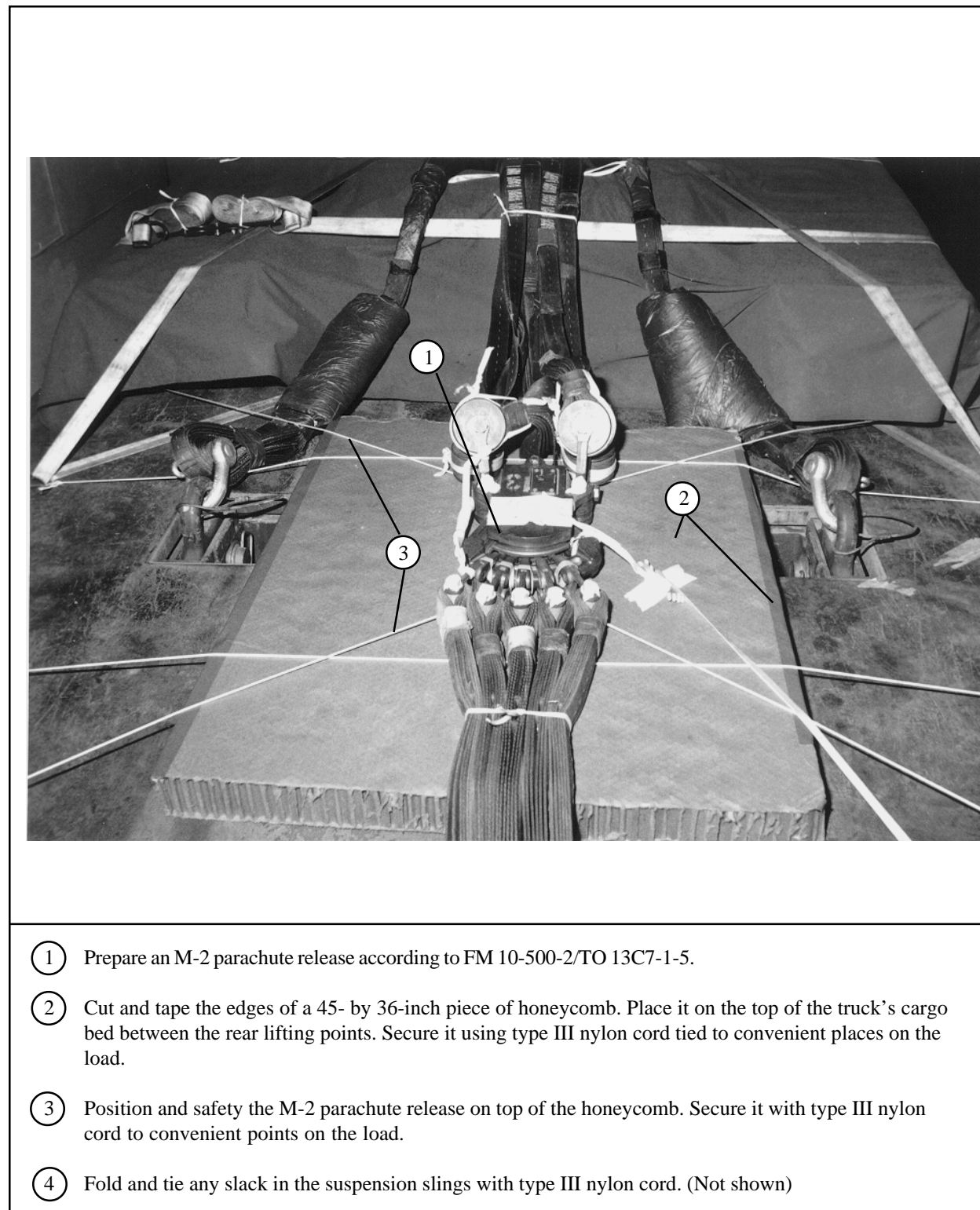

Figure 2-20. Parachute release installed

2-14. Installing Provisions for Emergency Restraints

Select and install provisions for emergency restraints according to the emergency restraint requirements table found in FM 10-500-2/TO 13C7-1-5.

2-15. Placing Extraction Parachute

Select the extraction parachute and extraction parachute line needed using the extraction parachute and extraction line requirements table found in FM 10-500-2/TO 13C7-1-5.

2-16. Marking the Rigged Load

Mark the rigged load according to FM 10-500-2/TO 13C7-1-5 and as shown in *Figure 2-21*. Complete Shipper's Declaration for Dangerous Goods and affix to load. If the load varies from the one shown, the weight, height, CB, tip-off curve and parachute requirements must be recomputed.

2-17. Equipment Required

Use the equipment listed in *Table 2-2* to rig this load.

CAUTION

Make the final rigger inspection required by
FM 10-500-2/TO 13C7-1-5 before the load leaves the rigging site.

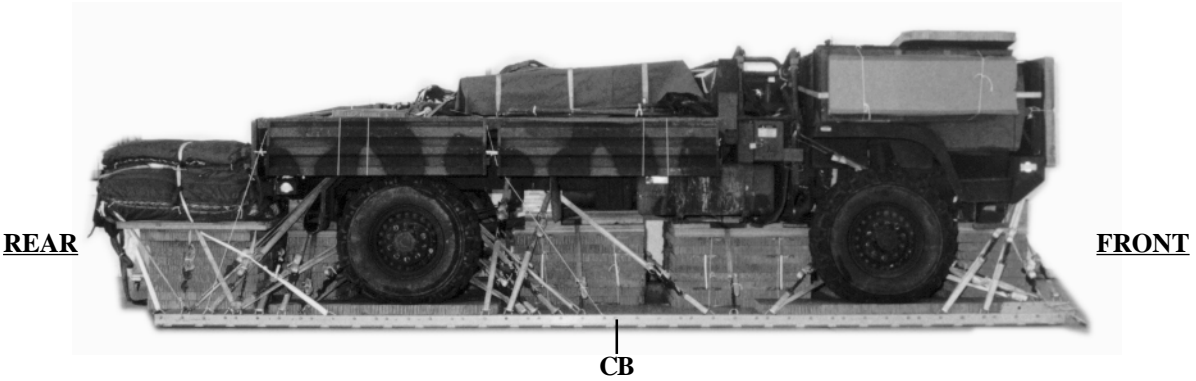

RIGGEDLOADDATA

Weight: Load shown	23,181 pounds
Minimum weight:	22,500 pounds
Maximum weight:	23,000 pounds
Height:	93 inches
Width:	108 inches
Length:	315 inches
Overhang: Front:	0 inch
Rear:	27 inches
Center of Balance: (from the front edge of the platform)	135 inches
Extraction System	EFTC

Figure 2-21. M1081, 2 1/2-ton cargo truck rigged for low-velocity airdrop

Table 2-2. Equipment required for rigging the M1081, 2 1/2-ton cargo truck for low-velocity airdrop on a type V platform

National Stock Number	Item	Quantity
8040-00-273-8713	Adhesive, paste, 1-gal	As required
N/A	Bolts, (washers and nuts), 1/2- by 10-in	4
1670-01-035-6054	Bridle, extraction line bag (Use with extraction line bag)	1
4030-00-432-2516	Clevis, screw pin	4
4030-00-090-5354	Clevis, suspension, 1-in (large)	3
8305-00-242-3593	Cloth, cotton duck, 60-in	As required
4020-00-240-2146	Cord, nylon, type III, 550-lb	As required
1670-00-434-5787	Coupling, airdrop extraction force transfer cable, 20-ft	1
1670-00-360-0328	Cover, clevis, large	3
8135-00-664-6958	Cushioning material, packaging, (cellulose wadding)	As required
8305-00-958-3685	Felt, 1/2-in thick	As required
1670-01-183-2678	Leaf, extraction line, (line bag)	2
	Line, extraction line, type XXVI nylon webbing:	
1670-01-064-4452	60-ft (1-loop), drogue	1
1670-01-062-6313	60-ft (3-loop), type XXVI nylon webbing (for C-130)	1
1670-01-107-7651	140-ft (3-loop), type XXVI nylon webbing (for C-5, C-17, and C-141)	1
	Truck preparation Lumber:	
5510-00-220-6146	2- by 4- by 6	2
5510-00-220-6148	2- by 6- by 6	3
	2- by 6- by 13	1
5510-00-220-6274	4- by 4- by 6	2
	4- by 4- by 15	2
5530-00-128-4981	Plywood, 3/4-in: 10- by 10-in	1

Table 2-2. Equipment required for rigging the M1081, 2 1/2-ton cargo truck for low-velocity airdrop on type V platform (continued)

National Stock Number	Item	Quantity
	Link assembly:	
1670-01-783-5988	Type IV	6
	Two-point:	1
5303-00-435-8994	Bolt, 1-in diam, 4-in long	(2)
5310-00-232-5161	Nut, 1-in, hexagonal	(2)
1670-00-003-3454	Plate, side, 5 1/2-in	(2)
1670-00-007-3414	Spacer, large	(2)
1670-00-006-2752	Link, suspension tandem	2
	Lumber:	
1670-00-162-4981	2- by 6- by 48-in	2
	2- by 6- by 85-in	2
	Load spreader for honeycomb stack 1:	
	Lumber:	
5305-00-435-8994	2- by 8- by 12-in	2
	2- by 8- by 43-in	2
	Plywood, 3/4-in:	
1670-00-003-1954	7 1/2- by 12-in	2
5510-00-128-4981	14- by 7-in	2
5365-00-007-3414	24- by 43-in	2

Table 2-2. Equipment required for rigging the M1081, 2 1/2-ton cargo truck for low-velocity airdrop on a type V platform (continued)

National Stock Number	Item	Quantity
	Load spreader for honeycomb stack 2:	
5510-00-220-6148	Lumber, 2- by 6- by 18-in	2
5530-00-128-4981	Plywood, 3/4-in:	
	5 1/2- by 18-in	6
	18- by 48-in	2
	Load spreader for honeycomb stack 3:	
5510-00-220-6246	Lumber, 2- by 8- by 26 1/2-in	2
5530-00-129-7777	Plywood, 1/2-in:	
	7 1/2- by 26 1/2-in	1
5510-00-128-4981	Plywood, 3/4-in:	
	6- by 8-in	1
	7 1/2- by 8-in	2
	8- by 16-in	1
	10- by 10-in	1
	12- by 14-in	4
	46- by 48-in	4
	Load spreader for honeycomb stack 4:	
	Lumber:	
5510-00-220-6148	2- by 6- by 21-in	6
	2- by 6- by 48-in	1
5510-00-220-6250	2- by 12- by 12-in	6
	2- by 12- by 34- in	2
5510-00-220-6448	Plywood 3/4-in:	
	44- by 48-in	3

Table 2-4. Equipment required for rigging the M1081, 2 1/2-ton cargo truck for low-velocity on type V airdrop platform (continued)

National Stock Number	Item	Quantity
	Load spreader for honeycomb stack 5:	
5510-00-220-6148	Lumber, 2- by 6- by 18-in	2
5530-00-128-4981	Plywood, 3/4-in:	
	5 1/2- by 18-in	6
	18- by 60-in	2
	Load spreader for honeycomb stack 6:	
	Lumber:	
5510-00-220-6148	2- by 6- by 8-in	6
	2- by 6- by 33-in	3
	2- by 6- by 45-in	4
5530-00-128-4981	Plywood, 3/4-in:	
	18- by 48-in	3
	Nail, steel wire, common:	
5315-00-010-4659	8d	As required
5315-00-753-3885	16d	As required
1670-00-753-3928	Pad, energy-dissipating, honeycomb,	
	3- by 36- by 96-in:	39 sheets
	4- by 6-in	1
	12- by 30-in	1
	12- by 31-in	12
	18- by 44-in	24
	18- by 48-in	13
	18- by 60-in	2
	24- by 34-in	4
	36- by 44-in	4
	36- by 80-in	1
	36- by 96-in	10
	43- by 20-in	5
	43- by 30-in	2
	74- by 18-in	2
	96- by 18-in	2

Table 2-4. Equipment required for rigging the M1081, 2 1/2-ton cargo truck for low-velocity airdrop on a type V platform (continued)

National Stock Number	Item	Quantity
1670-01-016-7841	Parachute, cargo: G-11C	5
	Parachute, cargo extraction:	
1670-00-040-8135	28-ft,	1
1670-01-063-3715	15-ft	1
	Platform, AD, type V, 24-ft	1
1670-01-353-8425	Bracket assembly, coupling	(1)
1670-01-162-2372	Clevis, assembly (type V)	(58)
1670-01-353-8424	Extraction bracket assembly	(1)
1670-01-162-2381	Tandem link assembly (Multipurpose link)	(2)
1670-01-097-8817	Release, cargo parachute, M-2	1
	Sling, cargo, airdrop:	
	For deployment line:	
	9-ft (2-loop), type XXVI nylon webbing	1
	For lifting and suspension:	
1670-01-062-6306	3-ft (4-loop), type XXVI nylon webbing	2
1670-01-062-6310	11-ft (2-loop), type XXVI nylon webbing	2
1670-01-062-6307	12-ft (4-loop), type XXVI nylon webbing	2
	For riser extension:	
1670-01-062-6302	20-ft (2-loop), type XXVI nylon webbing	5

Table 2-2. Equipment required for rigging the M1081, 2 1/2-ton cargo truck for low-velocity airdrop on a type V platform (continued)

National Stock Number	Item	Quantity
5340-00-040-8219	Strap, parachute release, multi-cut with 3 knives	2
7510-00-266-5016	Tape, adhesive, 2-in (masking)	As required
7510-00-079-7906	Tape, pressure, 2-in (pressure sensitive)	As required
1670-00-937-0271	Tiedown assembly, 15-ft	79
	Webbing:	
8305-00-268-2411	Cotton, 80-lb	As required
8305-00-082-5752	Nylon, tubular, 1/2-in, 1,000-lb natural	As required
8305-00-263-3591	Type VIII	As required

Section II

RIGGING M1081, 2 1/2-TON CARGO TRUCK WITH ACCOMPANYING LOAD

2-18. Description of Load

The M1081, 2 1/2-ton cargo truck is rigged on a 24-foot, type V airdrop platform with six G-11 cargo parachutes and other items of airdrop equipment.

The load consists of the M1081, 2 1/2-ton cargo truck and accompanying load of 42 boxes of 105mm ammunition. This load is 97 inches in height, 108 inches in width, 315 inches in length and has a rigged weight of 28,014 pounds.

2-19. Preparing Platform

Prepare a 24-foot, type V platform as shown in *Figure 2-22*.

NOTES: 1. The nose bumper may or may not be installed.
2. Measurements given in this section are from the front edge of the platform NOT from the front edge of the nose bumper.

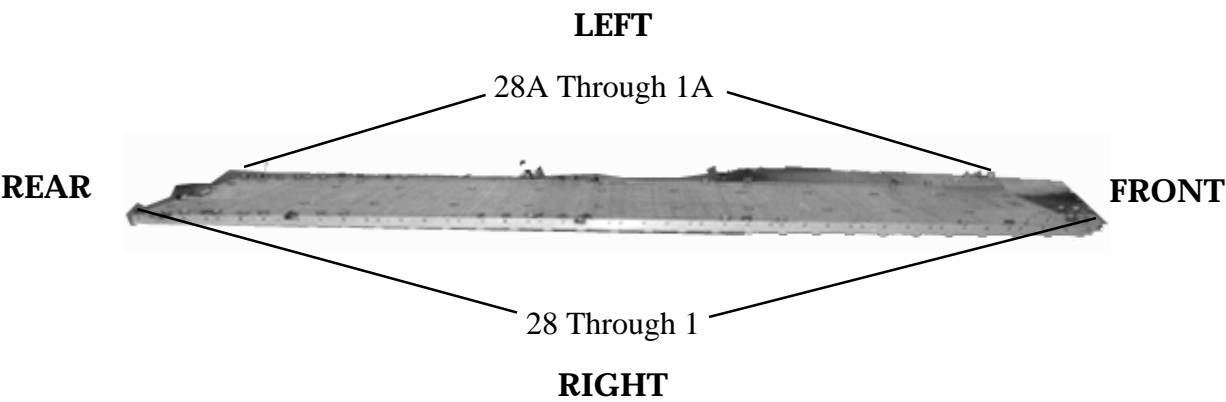

Step:

1. Inspect, or assemble and inspect, a 24-foot, type V airdrop platform as outlined in TM 10-1670-268-20&P/TO 13C7-52-22.
2. Install a tandem multi-purpose link to each platform side rail using holes 1, 2, and 3.
3. Attach clevises to each tandem link using bushings 1, 2, (tripled), and 3.
4. Starting at the front of each platform side rail, install clevises using bushings bolted to holes 5, 7, 16, 18, 19, 26 (doubled), 27, 28, 29, 30, 31, 38, 39, 41 (doubled), 42, 43, 44, 45, 46, 47, (tripled), and 48.
5. Starting at the front of the platform, number the clevises 1 through 28 on the right side and 1A through 28A on the left side.

Figure 2-22. Platform prepared

2-20. Preparing Honeycomb Stacks

Use the material in *Table 2-3* to prepare 10 honeycomb stacks as shown in *Figures 2-23 through 2-30*.

Table 2-3. Material needed to build honeycomb stacks.

Stack Number	Pieces	Width (Inches)	Length (Inches)	Material	Instructions
1	8	43	24	Honeycomb	See <i>Figure 2-23</i> .
	3	43	24	3/4-inch Plywood	
	3	2- by 8	43	Lumber	
	4	2- by 8	12	Lumber	
	4	12	7 1/2	3/4-inch Plywood	
	4	14	7	3/4-inch Plywood	
2	5	48	18	Honeycomb	See <i>Figure 2-24</i> .
	2	48	18	3/4-inch Plywood	
	2	2- by 6	18	Lumber	
	6	18	5 1/2	3/4-inch Plywood	
3	2	36	46	Honeycomb	See <i>Figure 2-25</i> .
	2	12	46	Honeycomb	
	12	18	46	Honeycomb	
	6	12	36	Honeycomb	
	4	48	46	3/4-inch Plywood	
	2	2- by 8	26 1/2	Lumber	
	1	7 1/2	26 1/2	1/2-inch Plywood	
	2	7 1/2	8	3/4-inch Plywood	
	1	8	16	3/4-inch Plywood	
	1	8	6	3/4-inch Plywood	
	1	10	10	3/4-inch Plywood	
	4	12	14	3/4-inch Plywood	
	4	2	36	44	
2		12	44	Honeycomb	
12		18	44	Honeycomb	
6		12	36	Honeycomb	
3		48	44	3/4-inch Plywood	
1		2- by 6	48	Lumber	
2		2- by 12	34	Lumber	
6		2- by 6	21	Lumber	
4		2- by 12	12	Lumber	
4		11 1/2	12	3/4-inch Plywood	

Table 2-3. Material needed to build honeycomb stacks (continued).

Stack Number	Pieces	Width (Inches)	Length (Inches)	Material	Instructions
5	5	60	18	Honeycomb	See Figure 2-27.
	2	60	18	3/4-inch Plywood	
	2	2- by 6	18	Lumber	
	6	5 1/2	18	3/4-inch Plywood	
6	8	48	18	Honeycomb	See Figure 2-28.
	3	48	18	3/4-inch Plywood	
	4	2- by 6	45	Lumber	
	6	2- by 6	8	Lumber	
	3	2- by 6	33	Lumber	
7	1	18	96	Honeycomb	See Figure 2-29
8	1	18	96	Honeycomb	See Figure 2-29.
9	1	18	74	Honeycomb	See Figure 2-30.
10	1	18	74	Honeycomb	See Figure 2-30.

NOTE: On all stacks the plywood must be cut to fit lumber. **EXAMPLE:** An 11 1/2- by 24 inch piece of plywood sits on a 2- by 12- by 24-inch piece of lumber but hangs over a 1/2 inch on the 11 1/2 inch side. Cut it to 11 by 24 inches to insure it fits. This is not due to improper measurements but to the fact that lumber varies in true sizes.

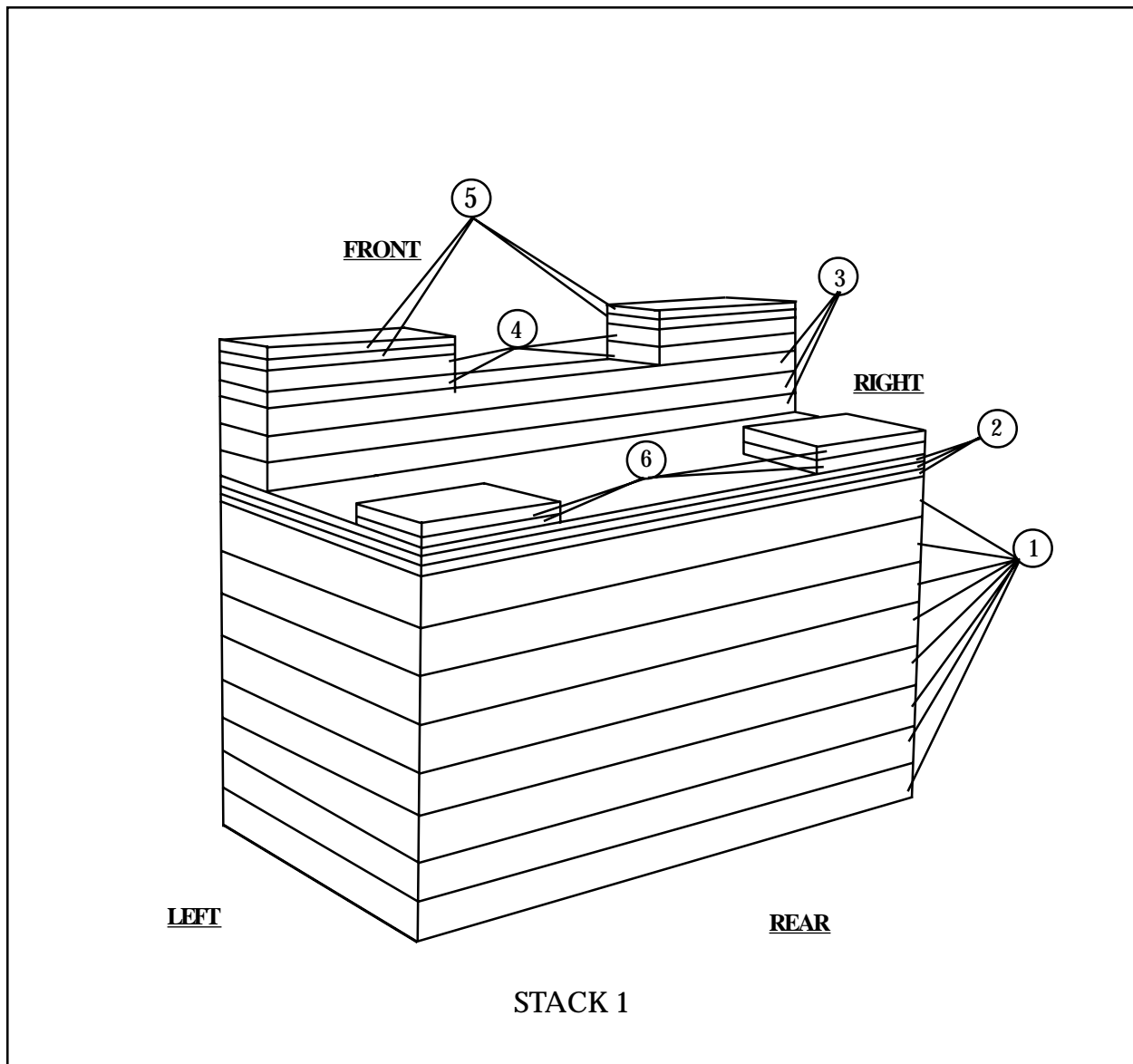

- ① Glue eight 43- by 24-inch pieces of honeycomb together to form a base.
- ② Glue and nail three 43- by 24-inch pieces of 3/4-inch plywood together. Glue the plywood to the top of the base.
- ③ Glue and nail three 2- by 8- by 43-inch pieces of lumber together. Center and glue the lumber flush with the front of base.
- ④ Glue and nail two 2- by 8- by 12-inch pieces of lumber together. Repeat with remaining two pieces, forming two stacks. Glue and nail one stack to the right side, and the other stack to the left side of previous 2- by 8- by 43-inch piece of lumber.
- ⑤ Glue and nail two 12- by 7 1/2- by 3/4-inch pieces of plywood together. Repeat with remaining two pieces, forming two stacks. Glue and nail one stack to the right side, and the other stack to the left side of previous 2- by 8- by 12-inch piece of lumber.
- ⑥ Glue and nail two 14- by 7- by 3/4-inch pieces of plywood together. Repeat with remaining two pieces, forming two stacks. Glue one stack to the rear right side, and the other stack to the rear left side of base.

Figure 2-23. Stack 1 prepared

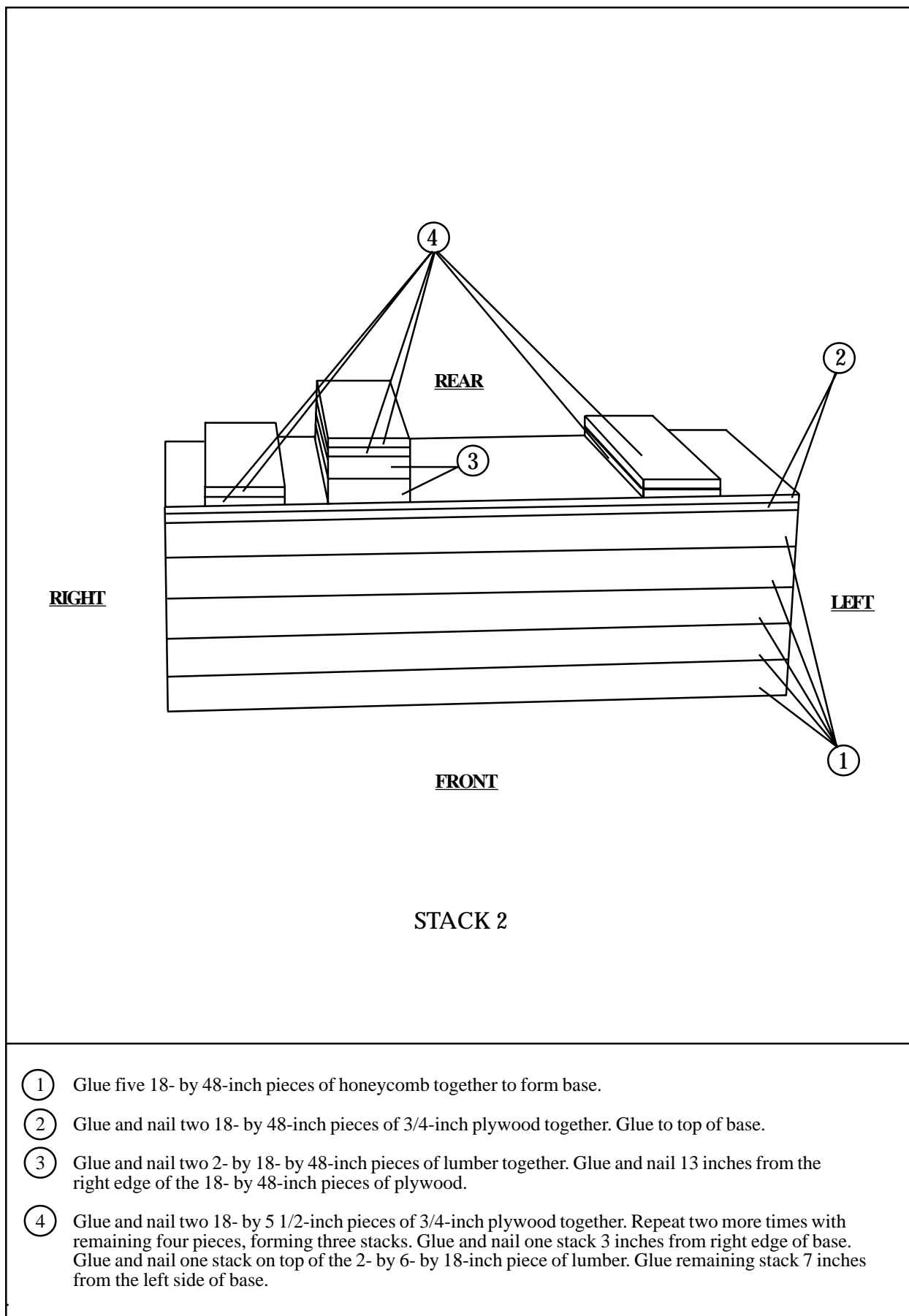

- ① Glue five 18- by 48-inch pieces of honeycomb together to form base.
- ② Glue and nail two 18- by 48-inch pieces of 3/4-inch plywood together. Glue to top of base.
- ③ Glue and nail two 2- by 18- by 48-inch pieces of lumber together. Glue and nail 13 inches from the right edge of the 18- by 48-inch pieces of plywood.
- ④ Glue and nail two 18- by 5 1/2-inch pieces of 3/4-inch plywood together. Repeat two more times with remaining four pieces, forming three stacks. Glue and nail one stack 3 inches from right edge of base. Glue and nail one stack on top of the 2- by 6- by 18-inch piece of lumber. Glue remaining stack 7 inches from the left side of base.

Figure 2-24. Stack 2 prepared

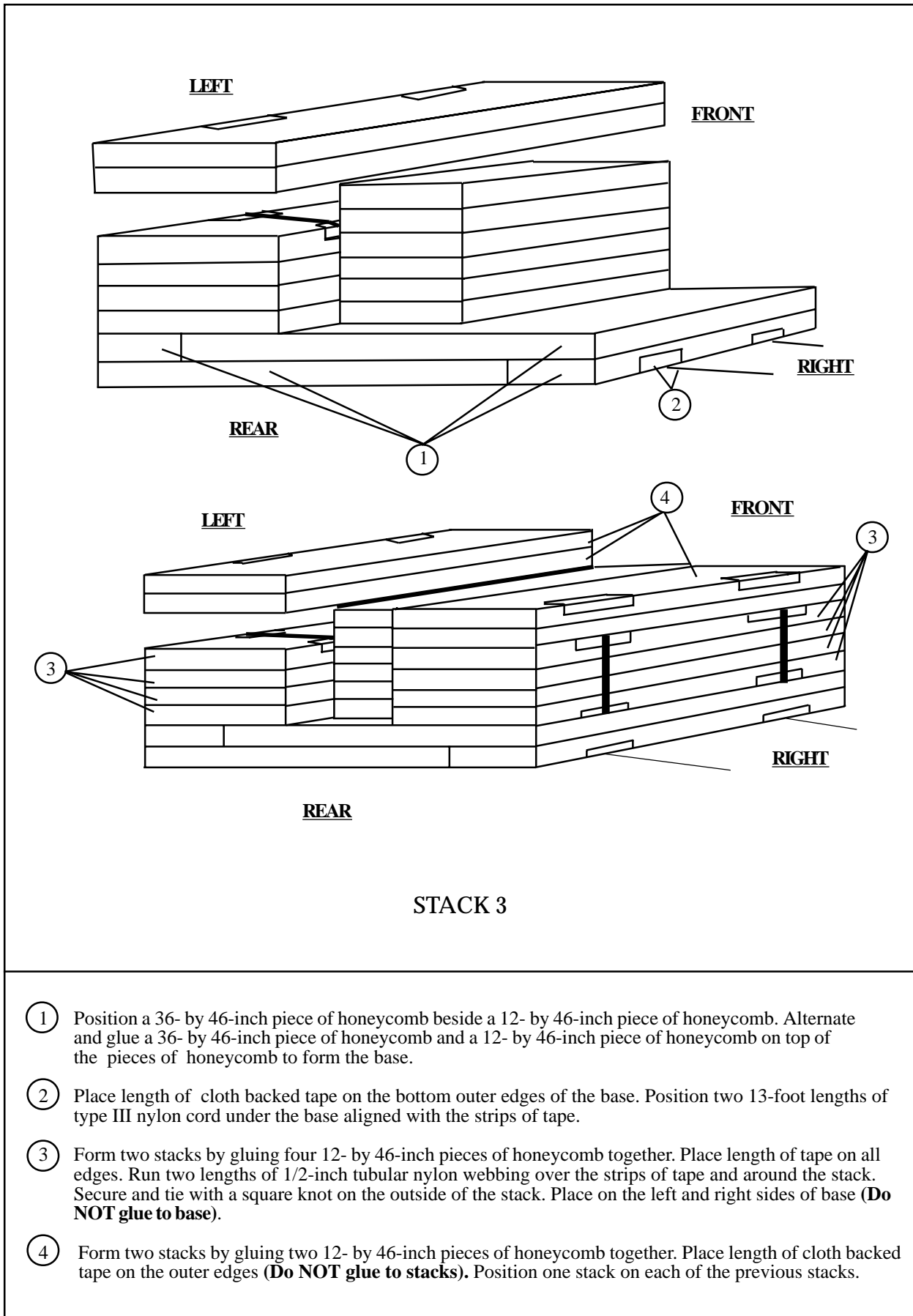

STACK 3

- ① Position a 36- by 46-inch piece of honeycomb beside a 12- by 46-inch piece of honeycomb. Alternate and glue a 36- by 46-inch piece of honeycomb and a 12- by 46-inch piece of honeycomb on top of the pieces of honeycomb to form the base.
- ② Place length of cloth backed tape on the bottom outer edges of the base. Position two 13-foot lengths of type III nylon cord under the base aligned with the strips of tape.
- ③ Form two stacks by gluing four 12- by 46-inch pieces of honeycomb together. Place length of tape on all edges. Run two lengths of 1/2-inch tubular nylon webbing over the strips of tape and around the stack. Secure and tie with a square knot on the outside of the stack. Place on the left and right sides of base (**Do NOT glue to base**).
- ④ Form two stacks by gluing two 12- by 46-inch pieces of honeycomb together. Place length of cloth backed tape on the outer edges (**Do NOT glue to stacks**). Position one stack on each of the previous stacks.

Figure 2-25. Stack 3 prepared

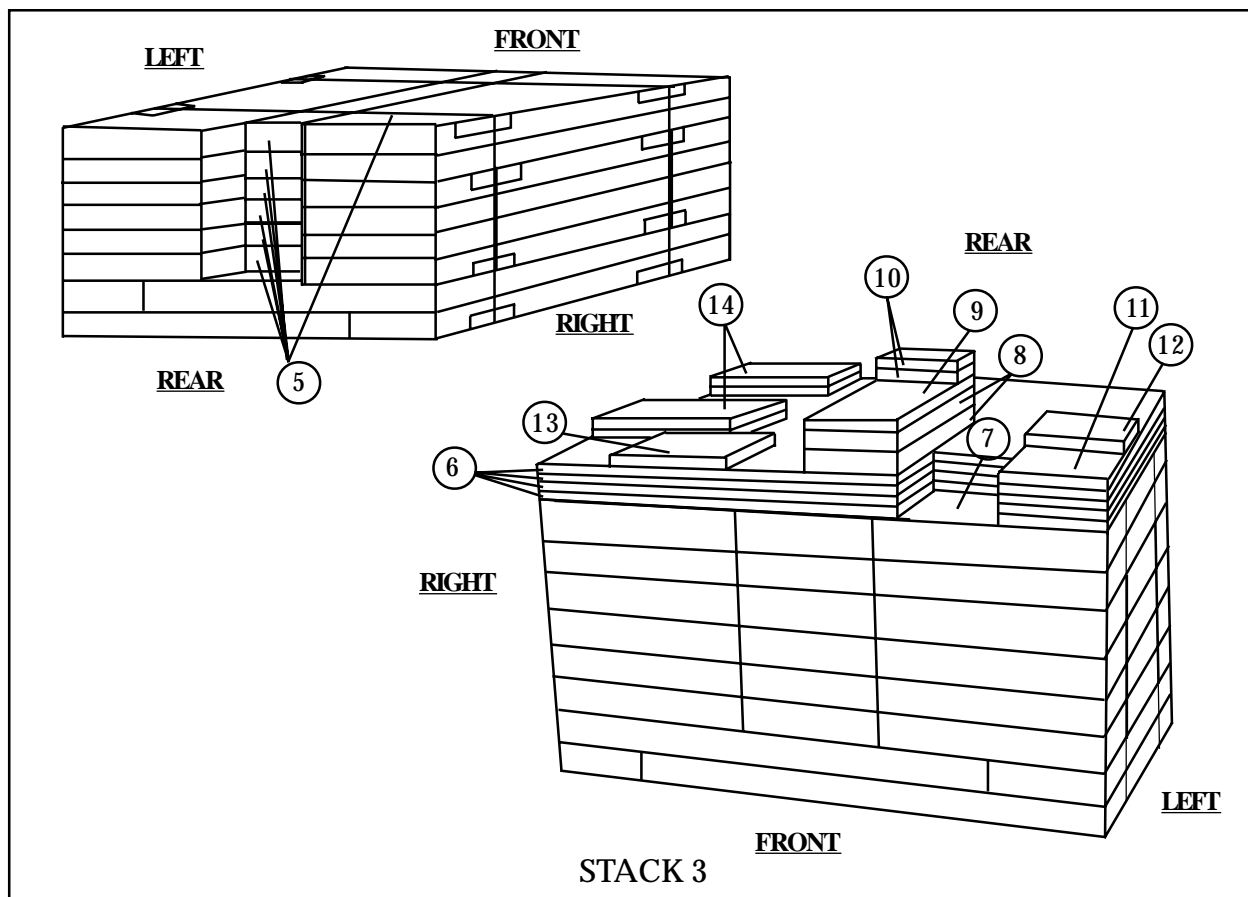

STACK 3

- ⑤ Glue six 12- by 36-inch pieces of honeycomb together to form a stack. Position between 18- by 46-inch stacks and flush with the front of base (**Do NOT glue to base**). Secure and tie the type III nylon cord around the completed honeycomb stack.
- ⑥ Glue and nail four 48- by 46-inch pieces of 3/4-inch plywood together. (**Do not build lumber stack on honeycomb stack. The lumber will be placed on the stack later.**)
- ⑦ Cut an 8-inch long, 12-inch deep cutout in the front of each of the 48-inch sides of plywood and 8 inches from the left 46 inch side of the plywood.
- ⑧ Glue and nail two 2- by 8- by 26 1/2-inch pieces of lumber flush with front edge and right edge of cutout. Glue and nail each piece separately.
- ⑨ Glue and nail a 7 1/2- by 26 1/2-inch piece of 1/2-inch plywood on top of the 2- by 8- by 26 1/2-inch piece of lumber.
- ⑩ Glue and nail two 7 1/2- by 8-inch pieces of 3/4-inch plywood. Glue the plywood flush and to the rear of the 7 1/2- by 26 1/2-inch pieces of 1/2-inch plywood.
- ⑪ Glue and nail a 8- by 16-inch piece of 3/4-inch plywood flush with front left edge of the 48- by 46-inch piece of 3/4-inch plywood.
- ⑫ Glue and nail a 8- by 6-inch piece of 3/4-inch plywood flush with rear left edge of the 8- by 16-inch piece of 3/4-inch plywood.
- ⑬ Glue and nail a 10- by 10-inch piece of 3/4-inch plywood flush with front edge, 8 inches from right side.
- ⑭ Form two stacks by gluing and nailing two 12- by 14-inch pieces of 3/4-inch plywood together. Position one stack against the rear edge of the 10- by 10-inch piece of 3/4-inch plywood. Ensure the 12 inch side is flush with right edge of the 48- by 46-inch piece of 3/4-inch plywood. Glue and nail the other stack flush with right rear edge of the 48- by 46-inch piece of 3/4-inch plywood. Ensure the 12 inch side is flush with right edge of the 48- by 46-inch piece of 3/4-inch plywood. Glue all lumber to honeycomb base.

Figure 2-25. Stack 3 prepared (continued)

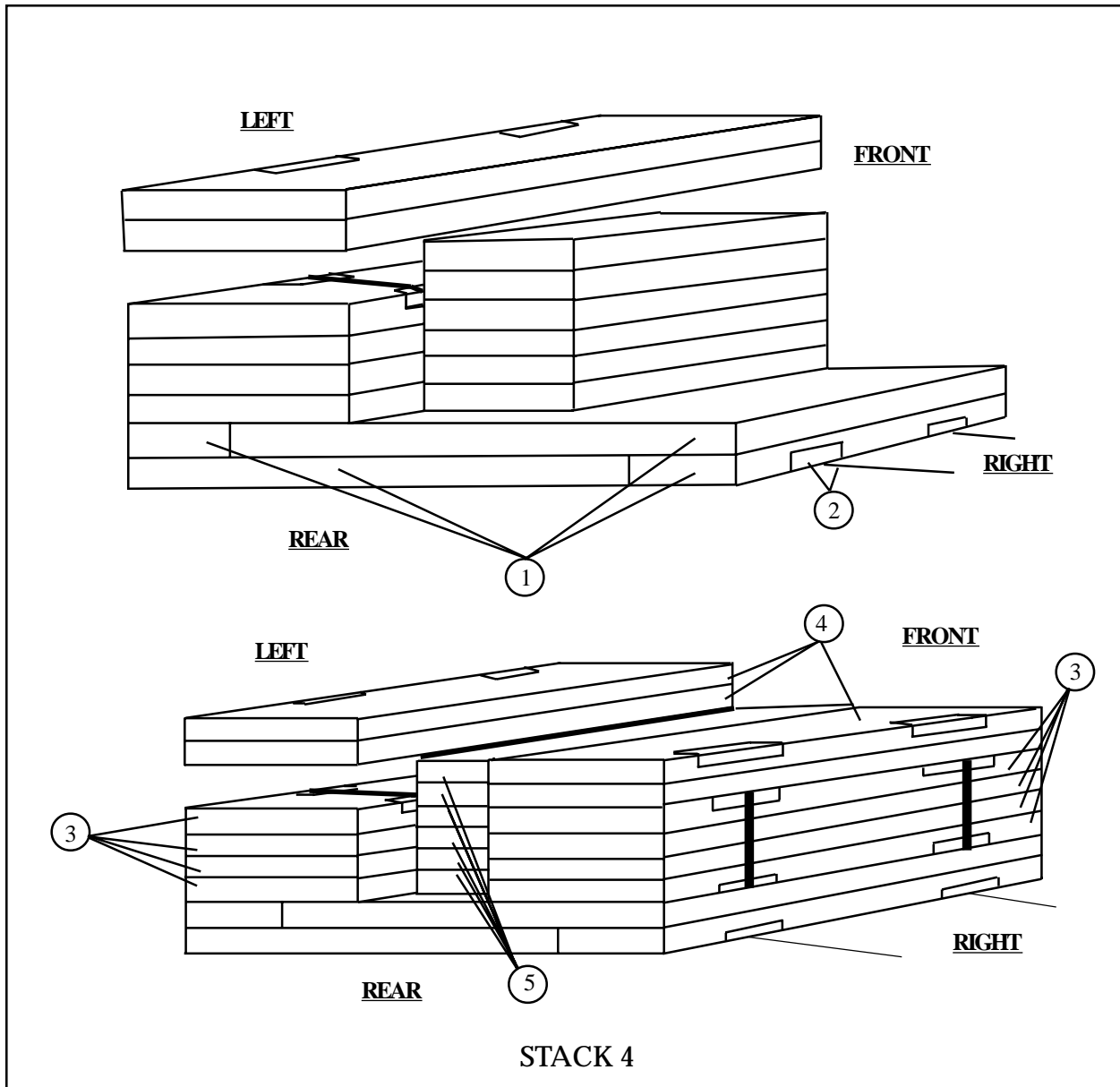

- ① Position a 36- by 44-inch piece of honeycomb beside a 12- by 44-inch piece of honeycomb. Alternate and glue a 36- by 44-inch piece of honeycomb and a 12- by 44-inch piece of honeycomb on top of the pieces of honeycomb to form the base.
- ② Place length of cloth backed tape on the bottom outer edges of the base. Position two 13-foot lengths of type III nylon cord under the base aligned with the strips of tape.
- ③ Form two stacks by gluing four 18- by 44-inch pieces of honeycomb together. Place length of tape on all edges. Run two lengths of 1/2-inch tubular nylon webbing over the strips of tape and around the stack. Secure and tie with a square knot on the outside of the stack. Place on the left and right sides of base (**Do NOT glue to base**).
- ④ Form two stacks by gluing two 12- by 44-inch pieces of honeycomb together. Place length of cloth backed tape on the outer edges (**Do NOT glue to stacks**). Position one stack on each of the previous stacks.
- ⑤ Glue six 12- by 36-inch pieces of honeycomb together to form a stack. Position between 18- by 44-inch stacks and flush with the front of base (**Do NOT glue to base**). Secure and tie the type III nylon cord around the completed honeycomb stack.

Figure 2-26. Stack 4 prepared

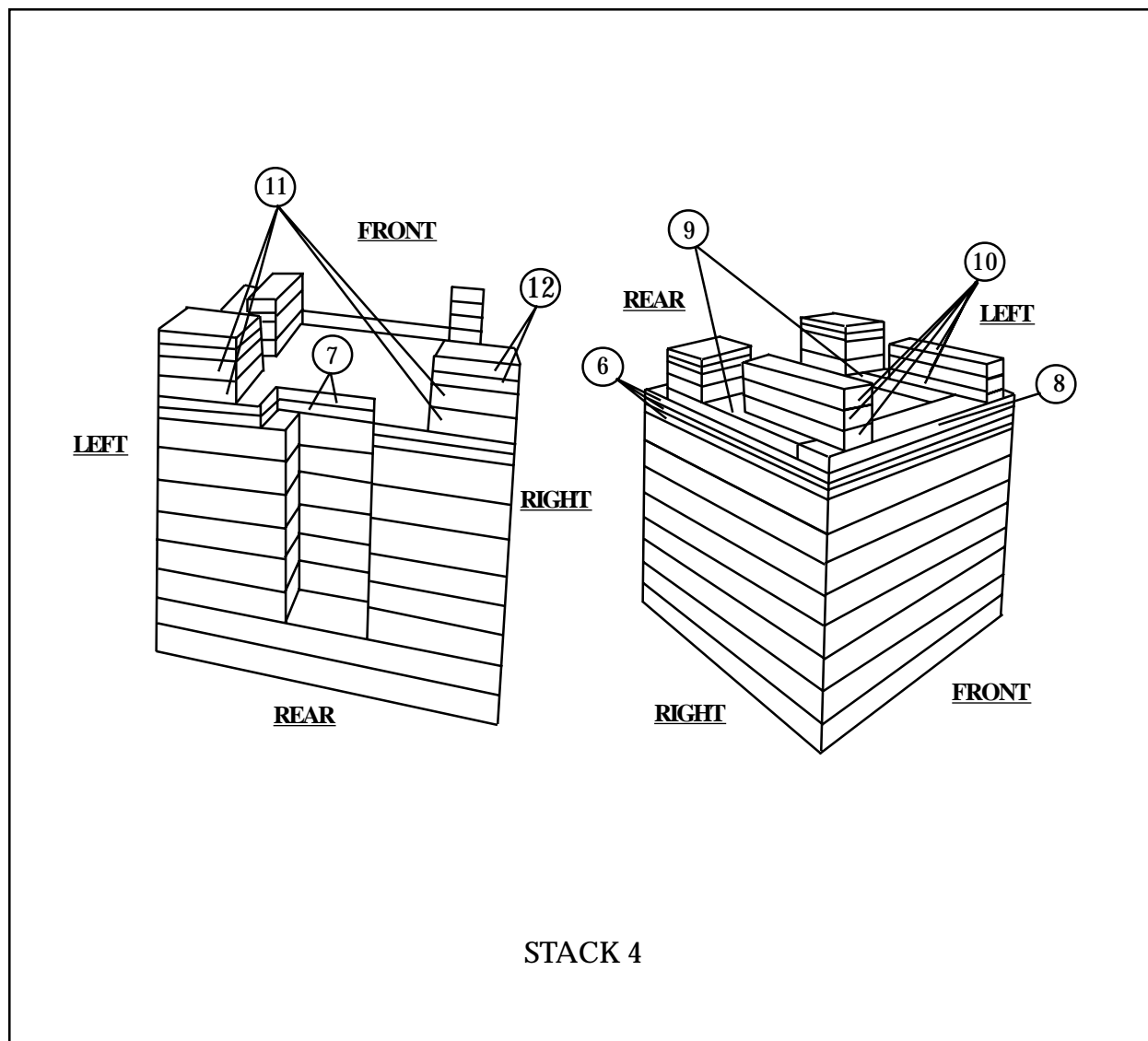

STACK 4

- ⑥ Glue and nail three 48- by 44-inch pieces of 3/4-inch plywood together. **(Do not build lumber stack on honeycomb stack. The lumber will be placed on the stack later.)**
- ⑦ Cut a 26-inch by 15-inch deep cutout centered in the rear of the 48-inch side of plywood.
- ⑧ Glue and nail a 2- by 6- by 48-inch piece of lumber with front edge of 48- by 44-inch piece of 3/4-inch plywood.
- ⑨ Glue and nail two 2- by 12- by 34-inch pieces of lumber, one piece flush with the left side and the other flush on the right side of the 48- by 44-inch piece of 3/4-inch plywood and against the 2- by 12- by 48-inch piece of lumber.
- ⑩ Form two stacks by gluing and nailing three 2- by 6- by 21-inch pieces of lumber together. Place one stack flush with the front of the 2- by 6- by 48-inch piece of lumber edge and 5 1/2 inches from the left edge. Glue and nail the other stack flush with the front of the 2- by 6- by 48-inch lumber edge and 5 1/2 inches from the right side.
- ⑪ Form two stacks by gluing and nailing two 2- by 12- by 12-inch pieces of lumber together. Place one stack flush with the rear right edge of the 2- by 12- by 34-inch piece of lumber. Repeat for the left side.
- ⑫ Form two stacks by gluing and nailing two 11 1/2- by 12-inch pieces of lumber together. Place one stack on top of the 2- by 12- by 12-inch lumber on right side. Glue and nail the other stack on top of the 2- by 12- by 12-inch lumber on the left side. Glue all lumber to honeycomb base.

Figure 2-26. Stack 4 prepared (continued)

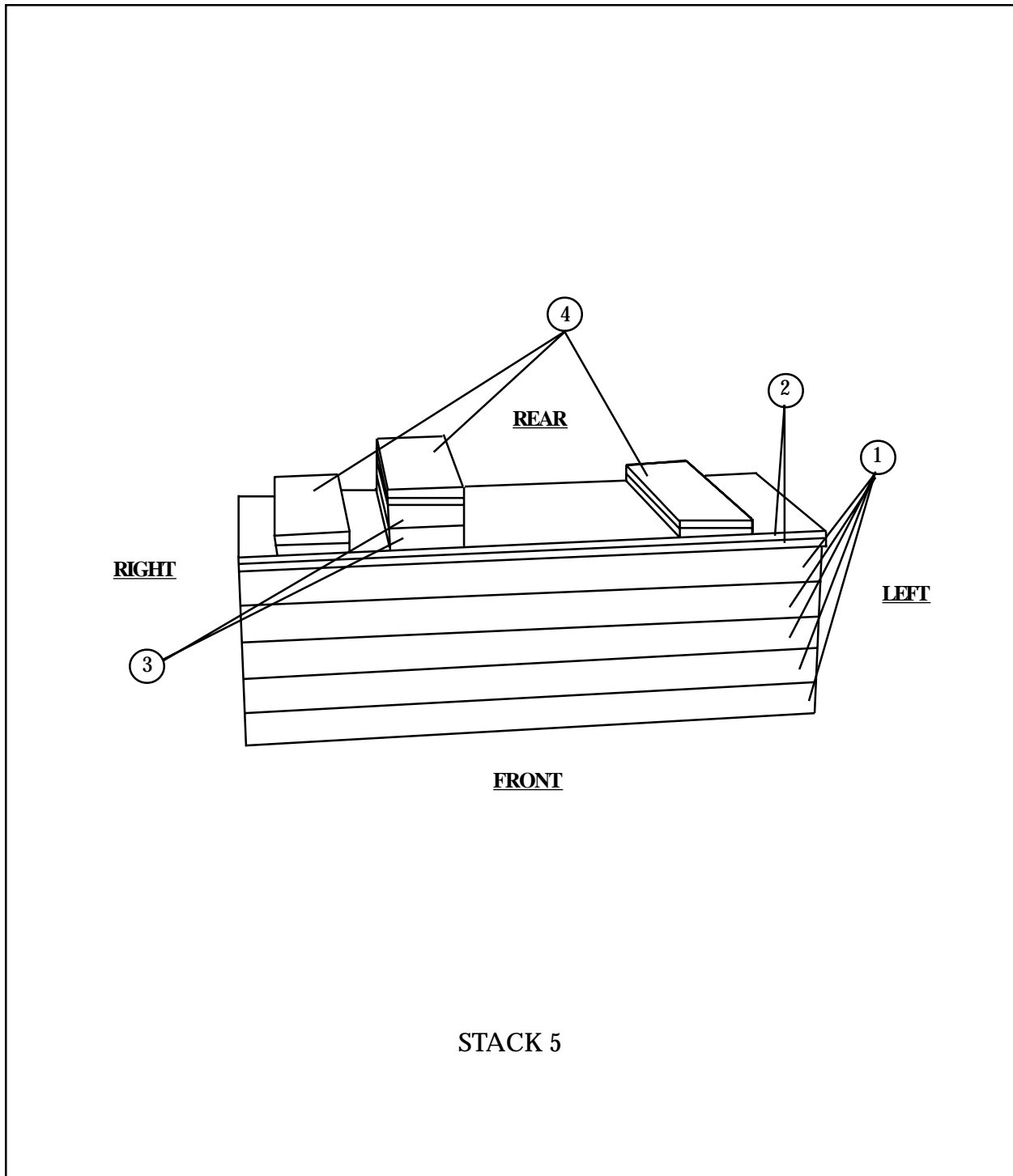

STACK 5

- ① Glue five 18- by 60-inch pieces of honeycomb together to form base.
- ② Glue and nail two 18- by 60-inch pieces of 3/4-inch plywood together. Glue to top of base.
- ③ Glue and nail two 2- by 6- by 18-inch pieces of lumber together. Glue and nail 16 1/2 inches from right edge of 18- by 60-inch piece of 3/4-inch plywood.
- ④ Form three stacks by gluing and nailing two 5 1/2- by 18-inch pieces of 3/4-inch plywood together. Glue one stack 5-inches from right edge of base. Glue another stack on top of the 2- by 6- by 18-inch piece of lumber. Glue the remaining stack 5 inches from the left side of base. Glue all lumber to honeycomb.

Figure 2-27. Stack 5 prepared

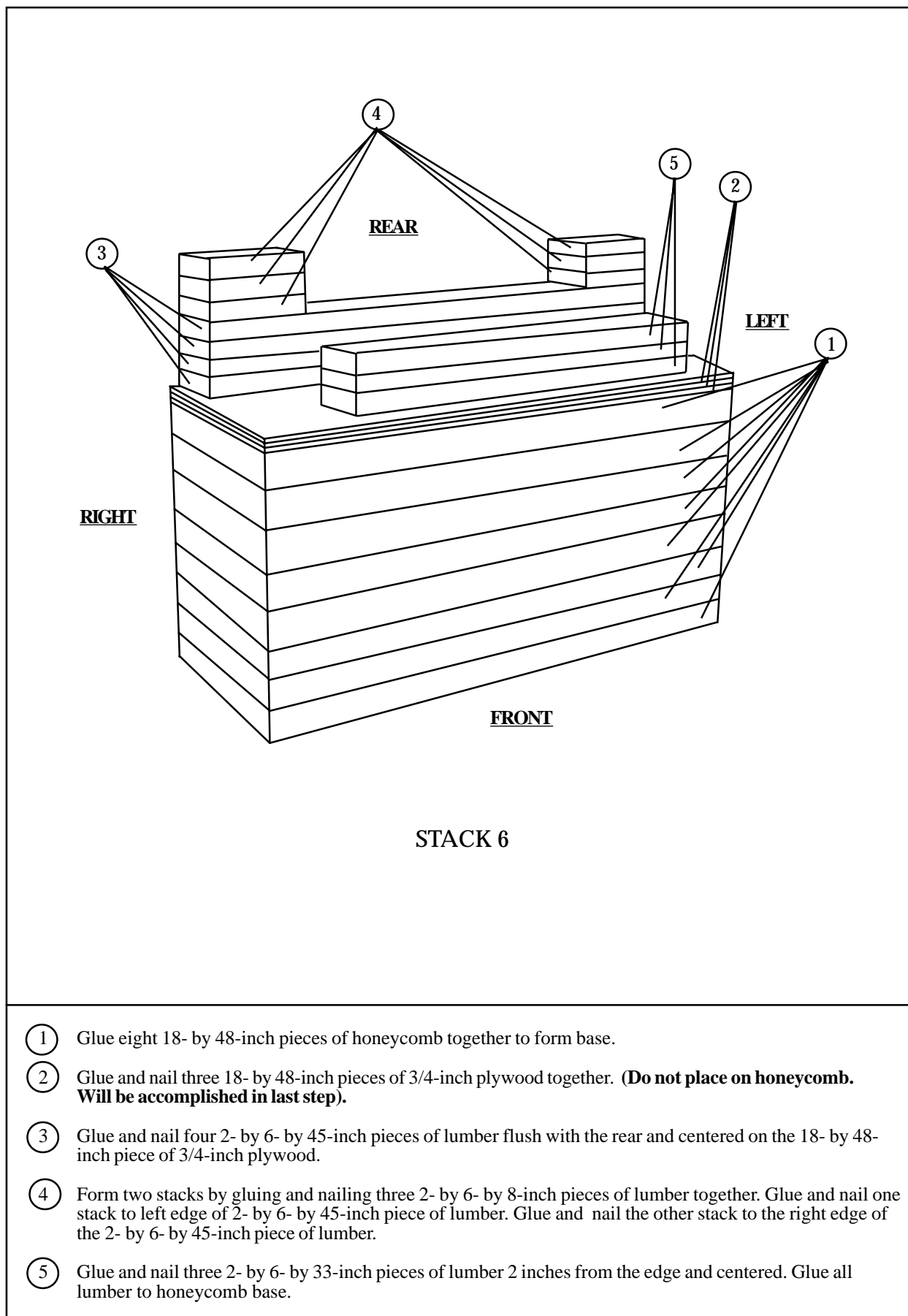

- ① Glue eight 18- by 48-inch pieces of honeycomb together to form base.
- ② Glue and nail three 18- by 48-inch pieces of 3/4-inch plywood together. **(Do not place on honeycomb. Will be accomplished in last step).**
- ③ Glue and nail four 2- by 6- by 45-inch pieces of lumber flush with the rear and centered on the 18- by 48-inch piece of 3/4-inch plywood.
- ④ Form two stacks by gluing and nailing three 2- by 6- by 8-inch pieces of lumber together. Glue and nail one stack to left edge of 2- by 6- by 45-inch piece of lumber. Glue and nail the other stack to the right edge of the 2- by 6- by 45-inch piece of lumber.
- ⑤ Glue and nail three 2- by 6- by 33-inch pieces of lumber 2 inches from the edge and centered. Glue all lumber to honeycomb base.

Figure 2-28. Stack 6 prepared

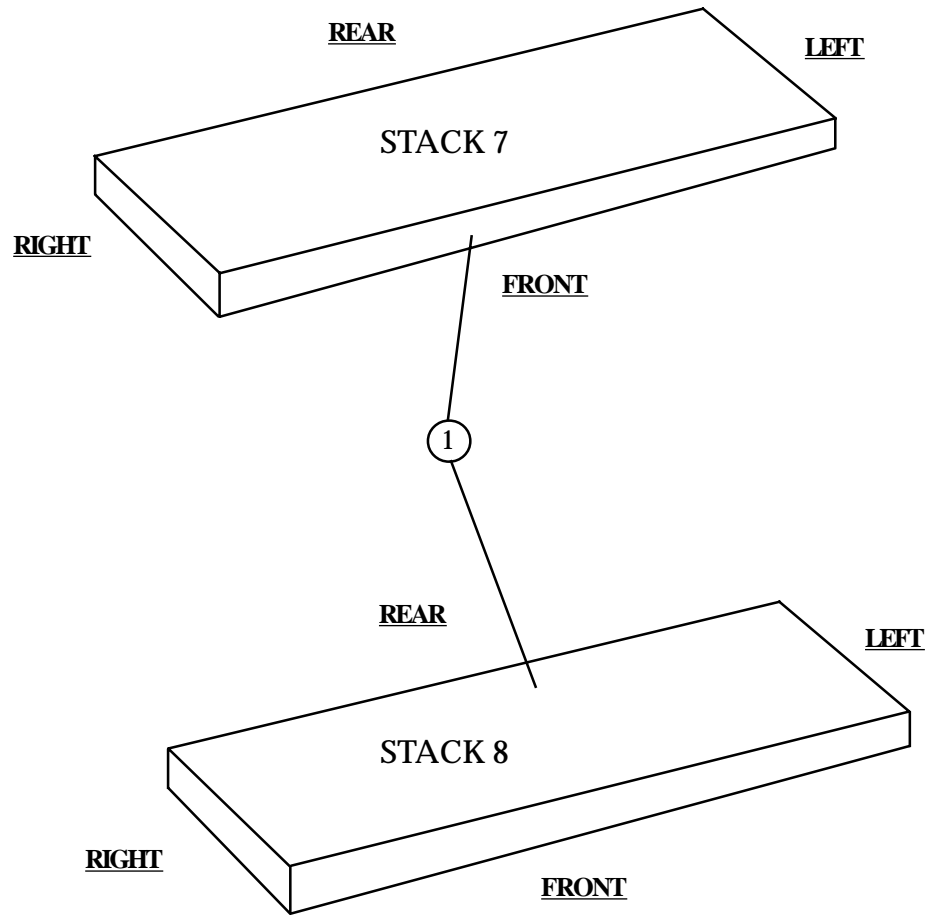

- ① Cut two 18- by 96-inch pieces of honeycomb. No further preparation is needed.

Figure 2-29. Stacks 7 and 8 prepared

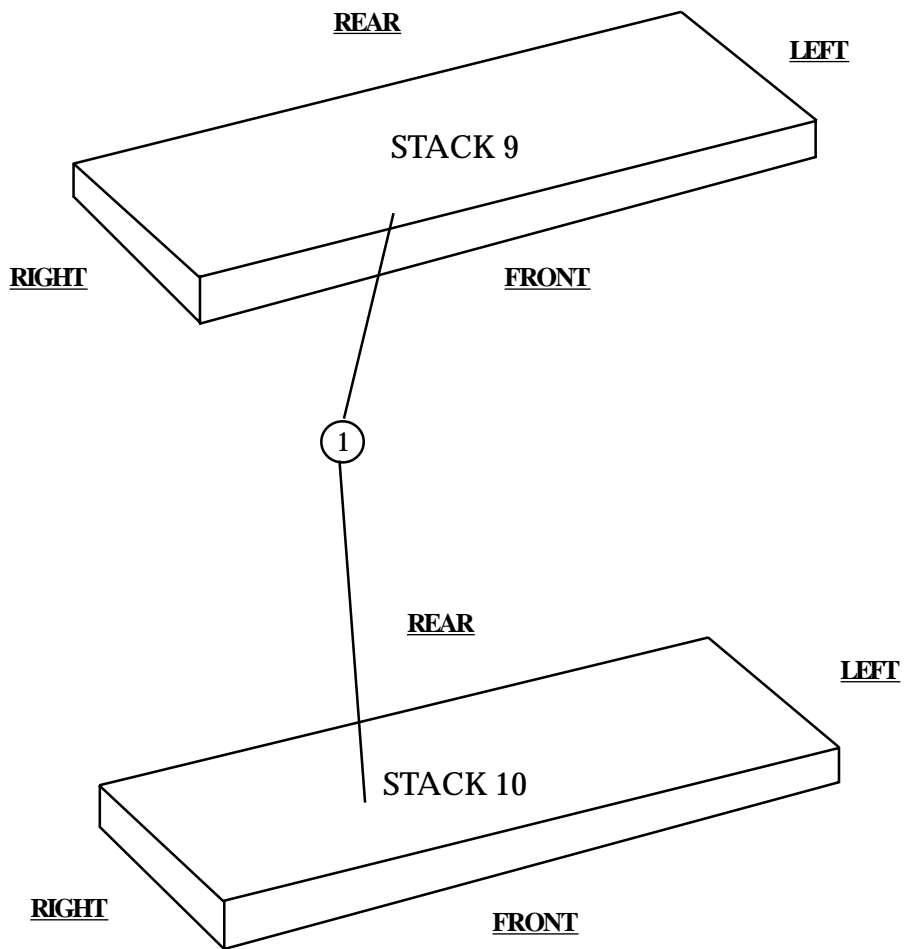

- ① Cut two 18- by 74-inch pieces of honeycomb. No further preparation is needed.

Figure 2-30. Stacks 9 and 10 prepared

2-21. Positioning Honeycomb Stacks

Position the honeycomb stacks as shown in *Figure 2-31*.

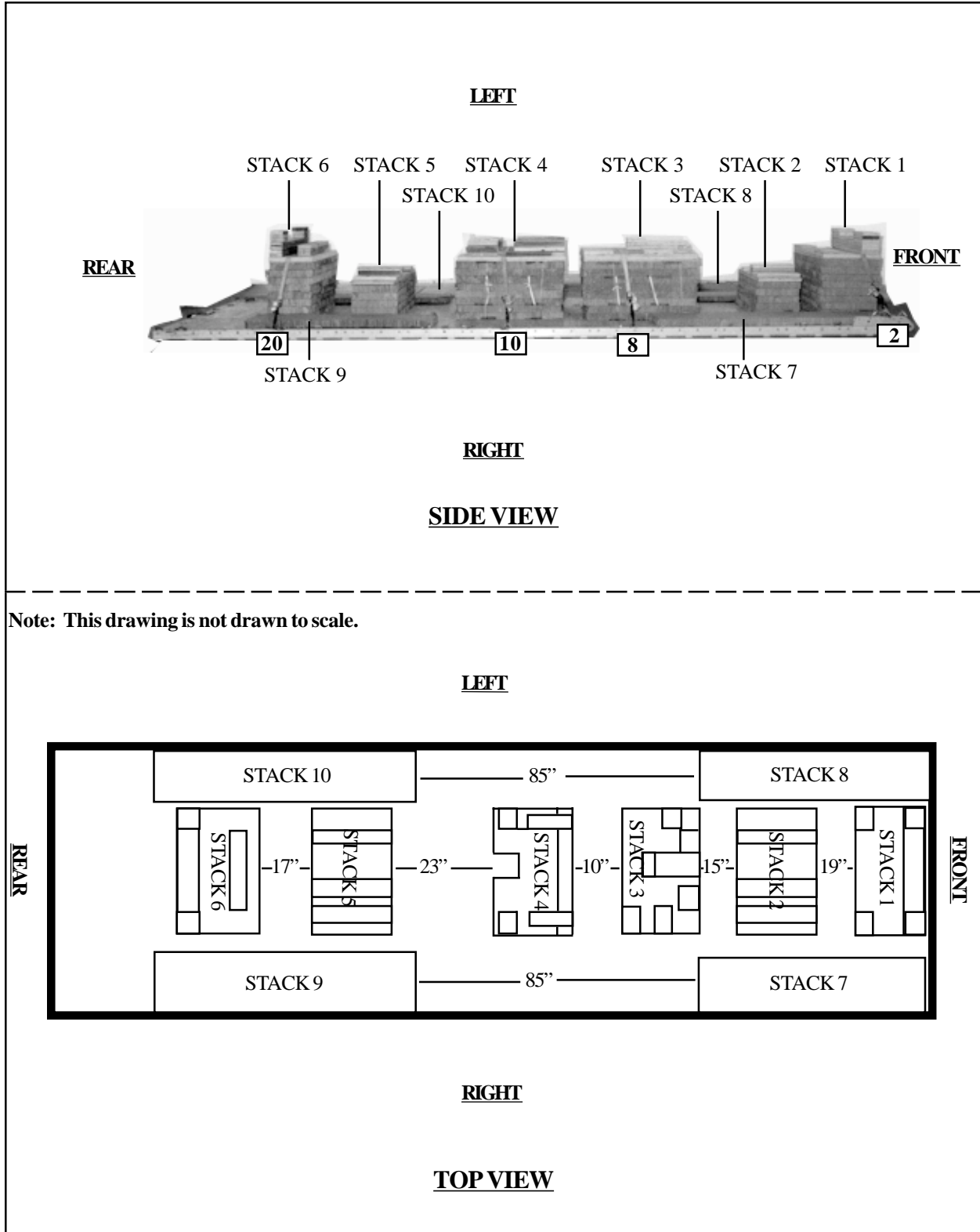

Figure 2-31. Honeycomb stacks positioned on platform

Stack Number	Instructions
1	Position stack 1, centered and flush with the front edge of the platform. Secure the stack by passing a lashing through clevis 2A and it's own D-ring. Route the lashing over the stack and secure it with a loadbinder to clevis 2.
2	Position stack 2, 19 inches from stack 1, 22 inches from the left side rail, and 28 inches from right side rail.
3	Position stack 3, 15 inches from stack 2, 30 1/4 inches from the left side rail and 19 1/4 inches from the right side rail. Secure the stack by passing a lashing through clevis 8A and it's own D-ring. Route the lashing over the stack and secure it with a loadbinder to clevis 8.
4	Position stack 4, 10 inches from stack 3, 25 1/2 inches from the left side rail and 24 1/4 inches from the right side rail. Secure the stack by passing a lashing through clevis 10A and it's own D-ring. Route the lashing over the stack and secure it with a loadbinder to clevis 10.
5	Position stack 5, 23 inches from stack 4, 19 1/4 inches from the left side rail, and 18 inches from right side rail.
6	Position stack 6, 17 inches from stack 5, 26 inches from the left side rail and 23 inches from the right side rail. Secure the stack by passing a lashing through clevis 20A and it's own D-ring. Route the lashing over the stack and secure it with a loadbinder to clevis 20.
7	Position stack 7, flush with the front edge of the platform and flush with the right side rail.
8	Position stack 8, flush with the front edge of the platform and flush with the left side rail.
9	Position stack 9, 85 inches from the rear of stack 7 and flush with the right side rail.
10	Position stack 10, 85 inches from the rear of stack 8 and flush with the left side rail.

Figure 2-31. Honeycomb stacks positioned on platform (Continued)

2-22. Preparing Truck

Prepare the M1081 truck as described below and as shown in *Figure 2-12*.

- a.* Make sure the fuel tank is 3/4 full.
- b.* Make sure the batteries and compartment comply with AFJMAN 24-204/TM 38-250.

The following is a list of materials used for truck preparation.

PIECES	WIDTH (inches)	LENGTH (inches)	MATERIAL
1	36	36	Honeycomb
1	36	80	Honeycomb
2	18	60	Honeycomb
10	2- by 6	13	Lumber
2	4- by 4	6	Lumber
2	4- by 4	15	Lumber
4	2- by 4	6	Lumber
1	10	10	3/4-inch Plywood
3	2- by 6	6	Lumber
1	36	96	Honeycomb
4	1/2	10	Bolts (washers and nuts)

- NOTES:**
- 1. The truck should arrive at the rigging site with the gun turret removed from roof and replaced with flat insert.**
 - 2. The cargo/troop cover, bows, seats, and rails located in the rear of the truck should be removed.**

2-23. Stowing Accompanying Load

Stow the accompanying load of forty-two boxes of 105 mm ammunition and vehicle parts as shown in *Figure 2-32*.

NOTE: Ensure the rear lifting points are in the up position.

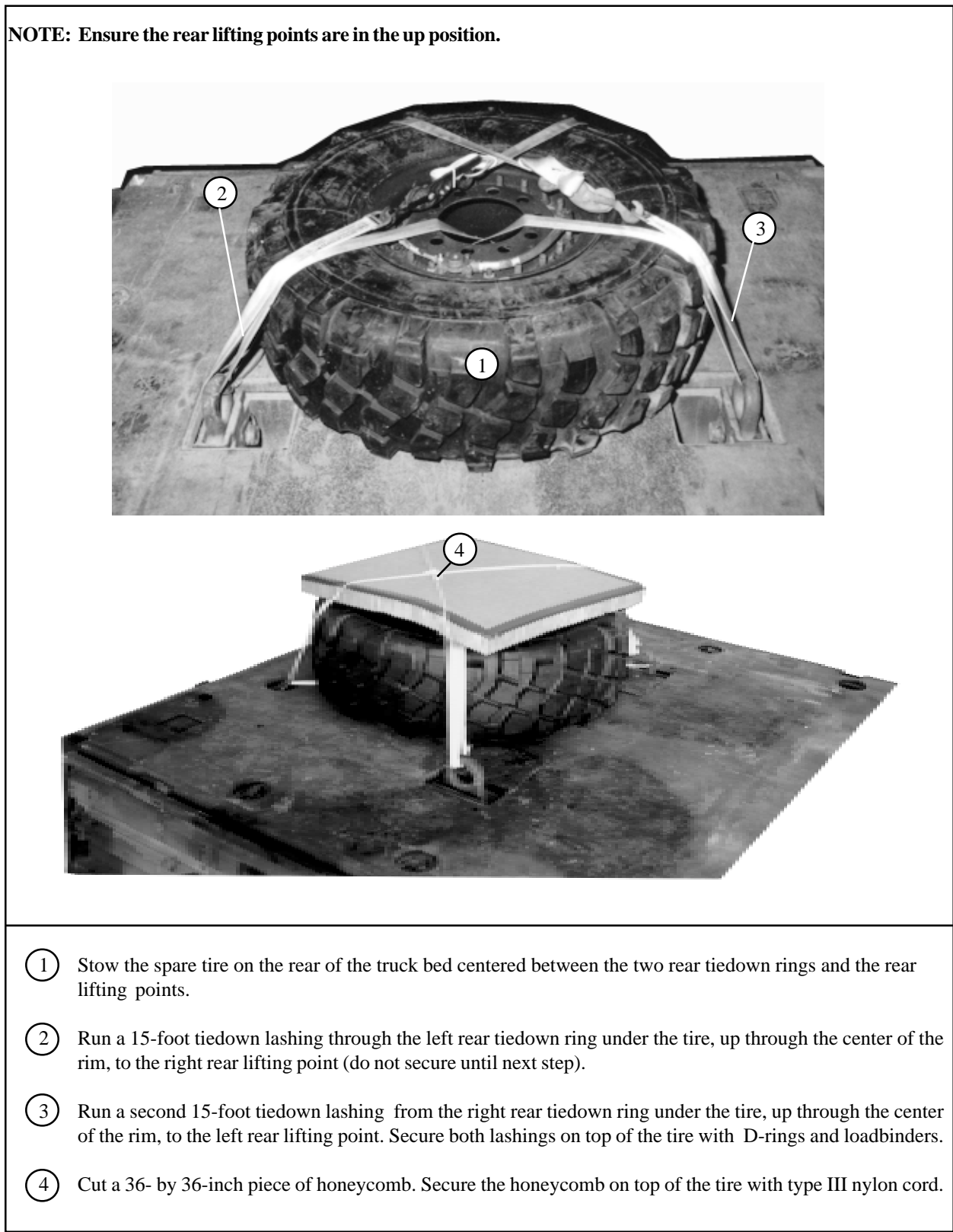

Figure 2-32. Accompanying load stowed

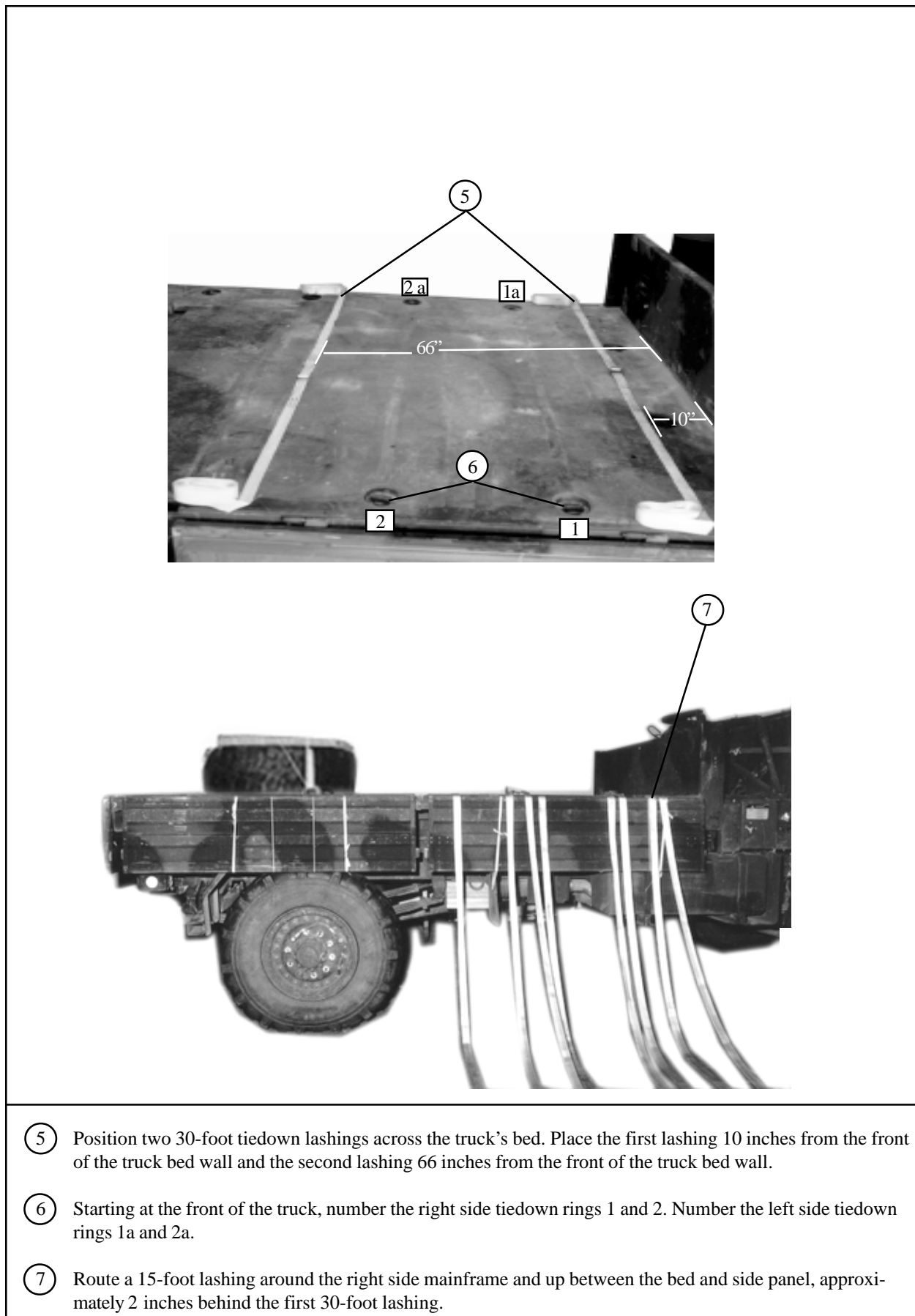
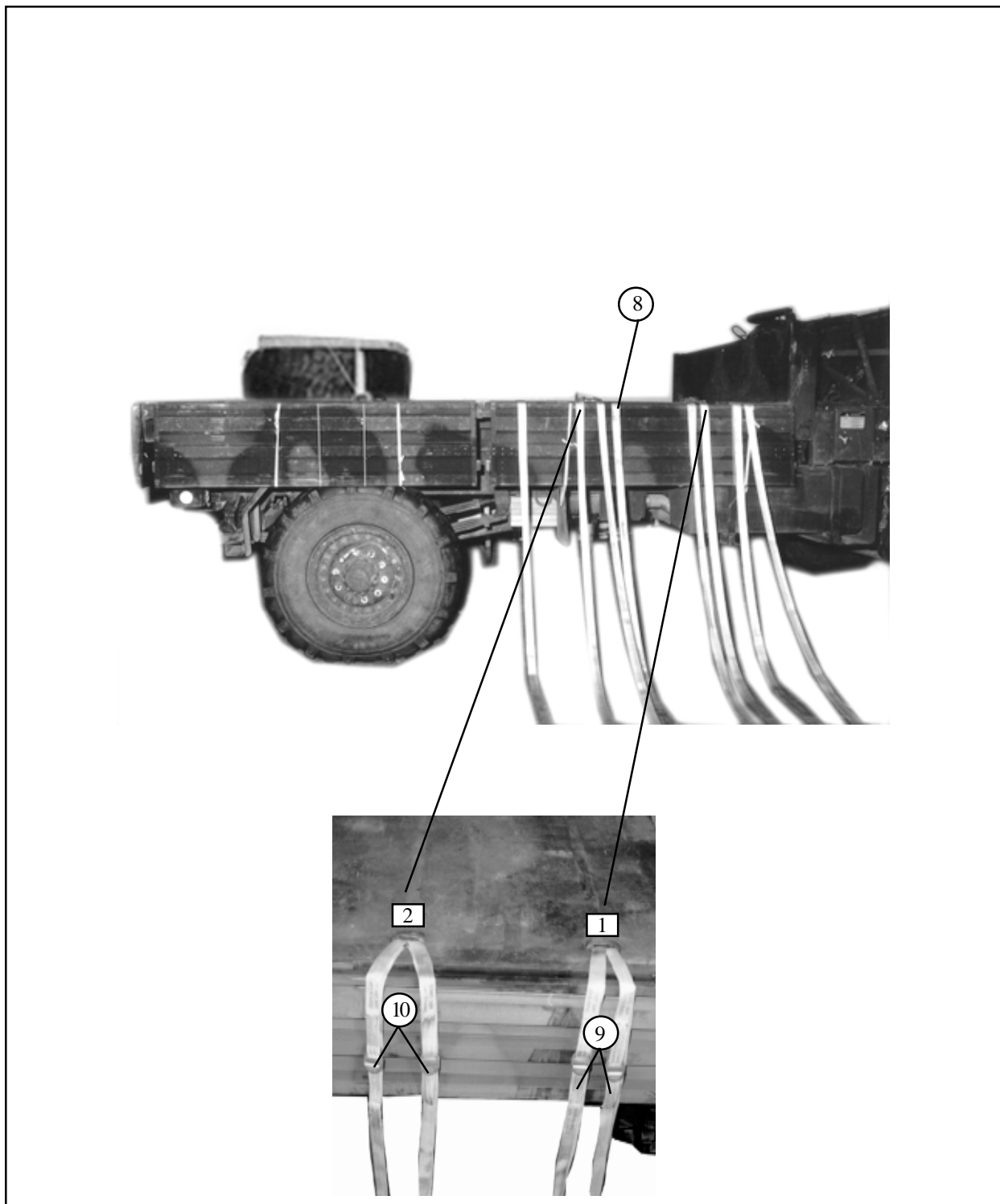

Figure 2-32. Accompanying load stowed (Continued)



- ⑧ Route a 15-foot lashing around the right side mainframe and up between the bed and side panel, approximately 2 inches in front of the truck bed tiedown ring 2. Repeat for the left side.
- ⑨ Route two 15-foot lashings through the truck bed tiedown ring 1, and through their own D-rings. Repeat for truck bed tie-down ring 1a.
- ⑩ Route two 15-foot lashings through the truck bed tiedown ring 2, and through their own D-rings. Repeat for truck bed tie-down ring 2a.

Figure 2-32. Accompanying load stowed (Continued)

Note: Before positioning 105-mm ammunition boxes, make sure that all tiedown rings are laying to the outside of the truck bed.

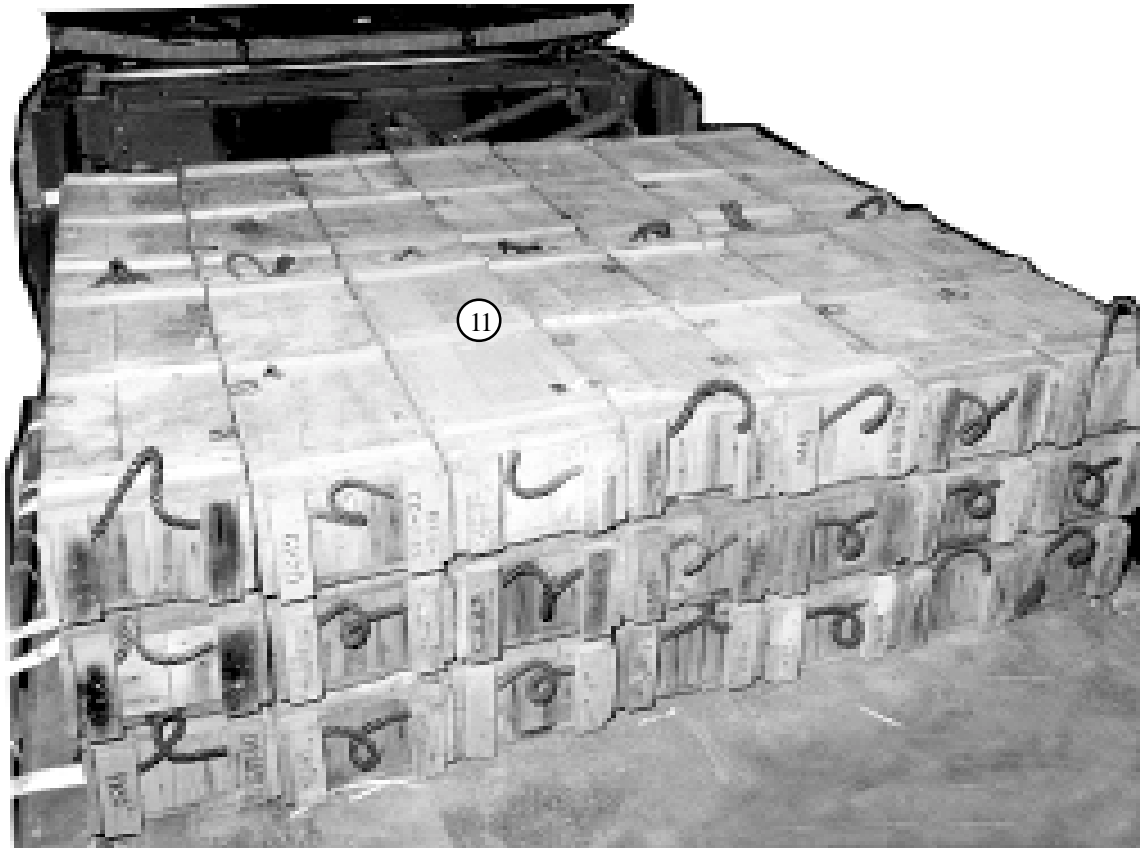

- ⑪ Position forty-two 105mm ammunition boxes on top of truck bed. Make sure the boxes against the front of the bed, two rows of seven boxes across and three boxes deep.

Figure 2-32. Accompanying load stowed(Continued)

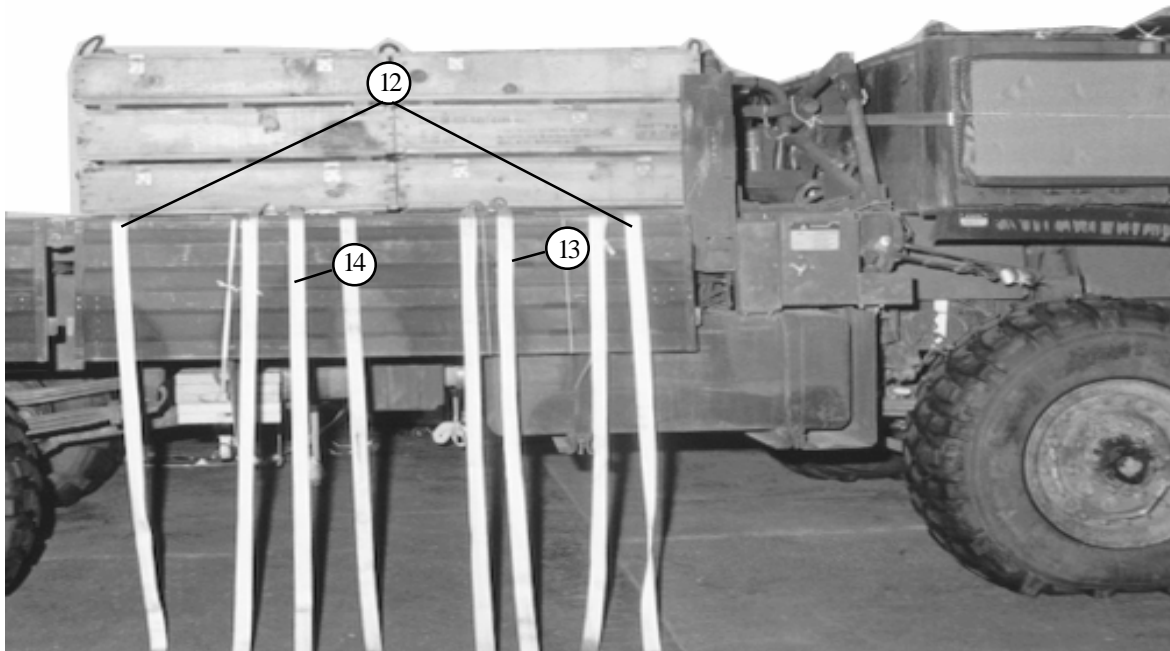

- ⑫ Secure each of the 30-foot lashings on top of the boxes.
- ⑬ Secure one 15-foot lashing from tiedown ring 1 together on the boxes with one lashing from tiedown ring 1a.
- ⑭ Secure one 15-foot lashing from tiedown ring 2 together on top of the boxes with one lashing from tiedown ring 2a.

Figure 2-32. Accompanying load stowed (Continued)

Note: This drawing is not drawn to scale.

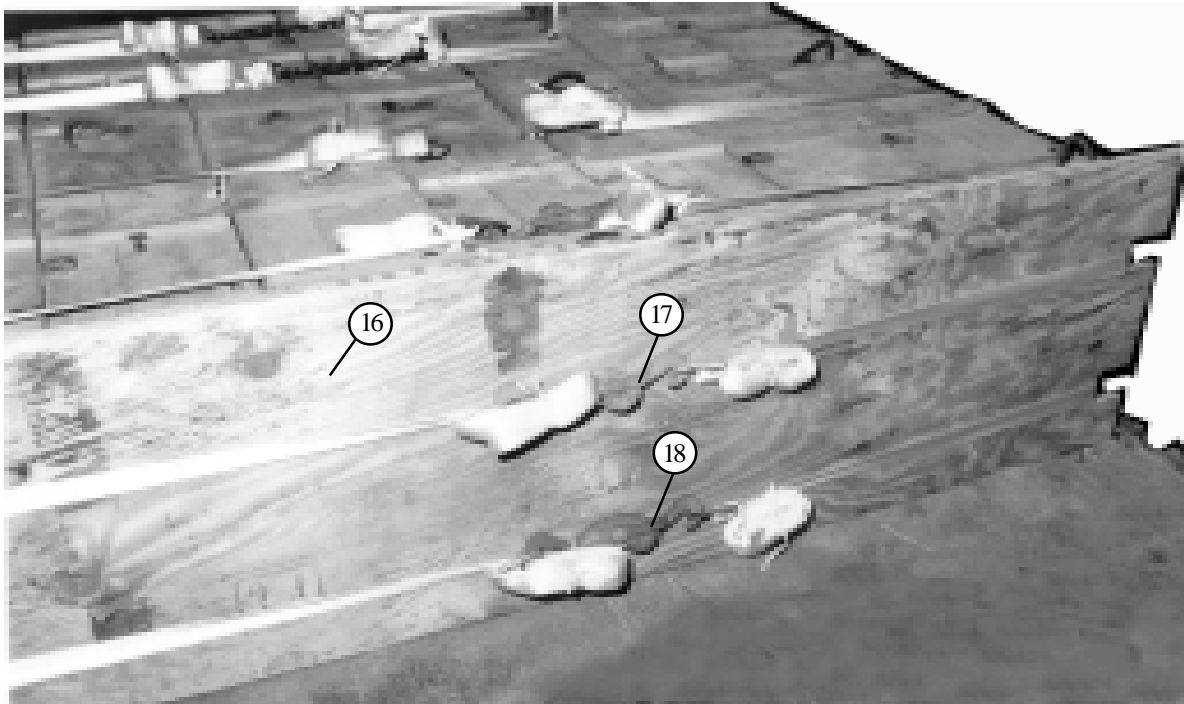
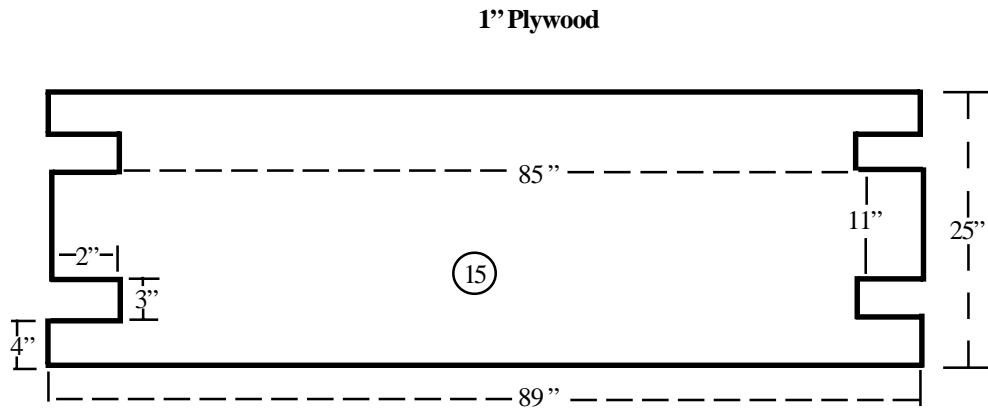

- (15) Cut an end-board as shown, using one sheet of 1-inch or two sheets of 1/2-inch plywood.
- (16) Position the end-board against the ammunition boxes.
- (17) Run the 15-foot lashings from tiedown rings 1 and 1a through the top cutouts. Secure together in the rear with D-rings and loadbinder.
- (18) Run the 15-foot lashings from tiedown rings 2 and 2a through the bottom cutouts. Secure together in the rear with D-rings and loadbinder.

Figure 2-32. Accompanying load stowed (Continued)

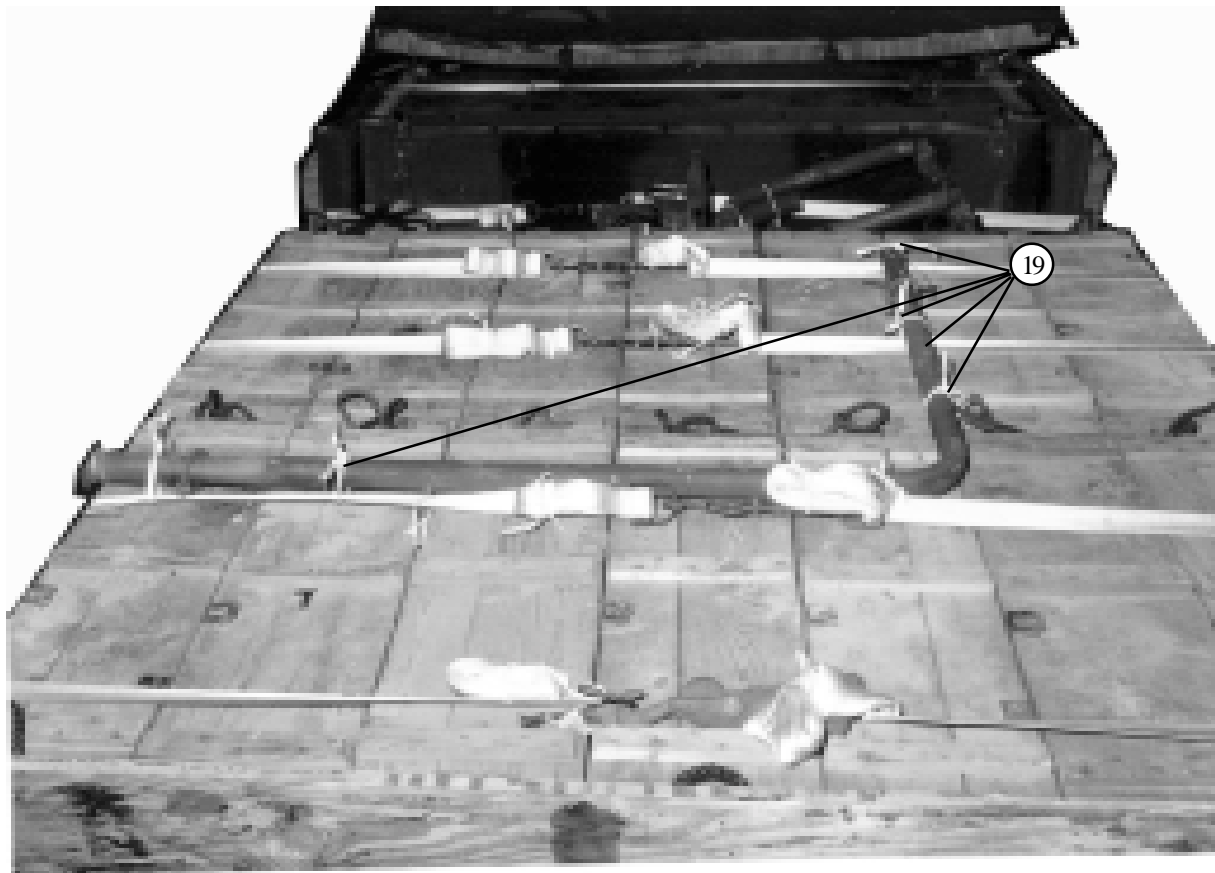

- ①9 Secure the spare tire davit on top of the boxes with 1/2-inch tubular nylon, tied to convenient points on the load.

Figure 2-32. Accompanying load stowed (Continued)

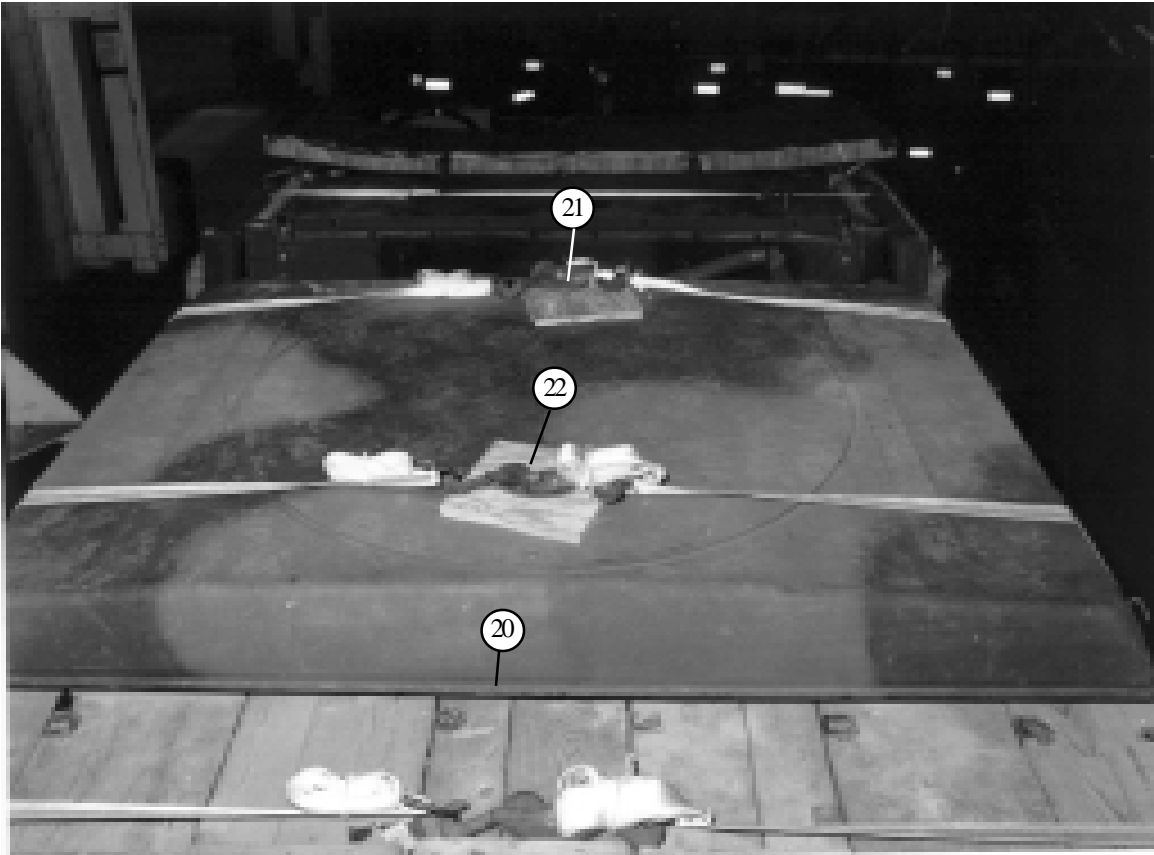

- ②① Position the roof on top of the ammunition boxes.
- ②① Secure the front lashing (routed around the mainframe) together on top of the roof with loadbinder and D-rings. Place a 14- by 14-inch piece of 3/4-inch plywood under the binder and tape to the roof.
- ②② Secure the rear lashing (routed around the mainframe) together on top of the roof. Place a 14- by 14-inch piece of 3/4-inch plywood under the binder and tape to the roof with loadbinder and D-rings.
- ②③ Secure all corners of the roof with 1/2-inch tubular nylon to convenient points on the load. (Not shown).

Figure 2-32. Accompanying load stowed (Continued)

2-24. Lifting and Positioning Truck

Install lifting sling on the M1081 truck and position the truck on the platform as shown in *Figure 2-33*.

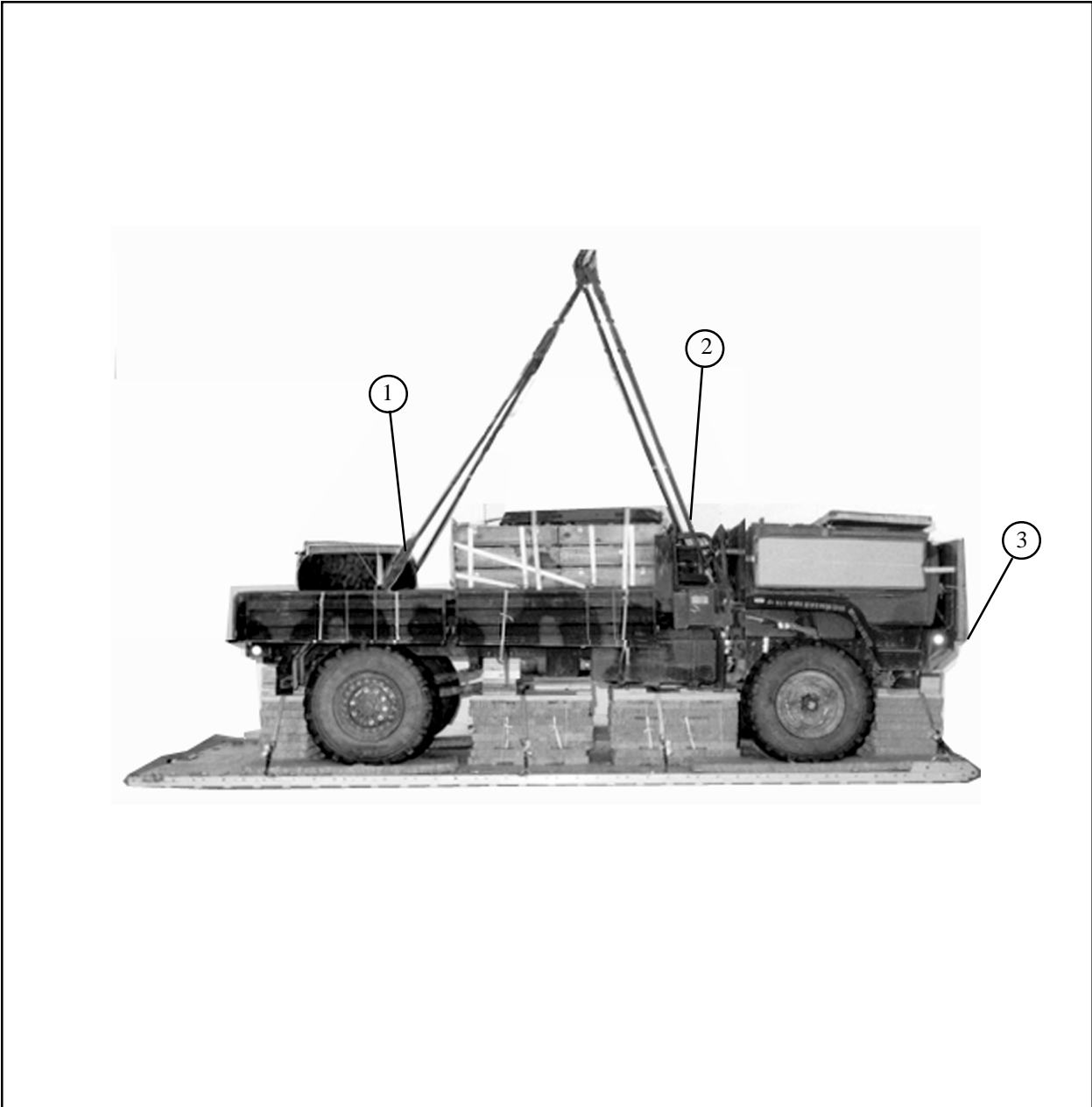

- ① Attach a 9-foot (4-loop), type XXVI sling to the rear lifting points with a clevis screw pin. Attach a 3-foot (4-loop), type XXVI sling to each of the rear slings with a 5 1/2-inch two-point link. Wrap the links with felt and tape.
- ② Attach a 11-foot (4-loop), type XXVI sling to each of the front lifting points with a clevis screw pin.
- ③ Position the truck on the platform so that the front of the truck is flush with the front edge of the platform.

Figure 2-33. Lifting slings installed and truck positioned on the platform

2-25. Installing Lashings

Lash the truck to the platform as shown in *Figure 2-34*.
Install the lashings according to FM 10-500-2/TO 13C7-1-5.

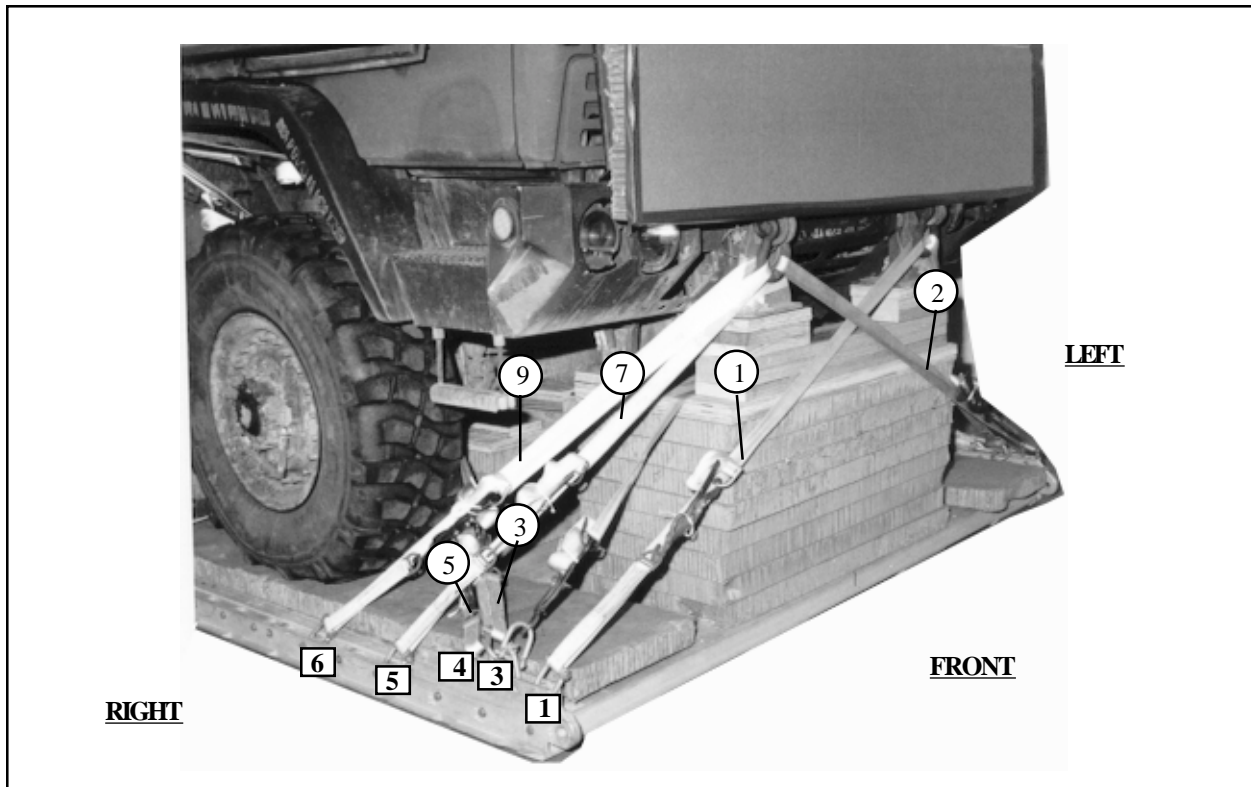

Lashing Number	Clevis Number	Instructions
1	1	Route a 15-foot lashing through the front shackle on the left side.
2	1a	Route a 15-foot lashing through the front shackle on the right side.
3	3	Route a 15-foot lashing around the front axle, right side.
4	3a	Route a 15-foot lashing around the front axle, left side.
5	4	Route a 15-foot lashing around the front axle, right side.
6	4a	Route a 15-foot lashing around the front axle, left side.
7	5	Route a 15-foot lashing through the front shackle on the right side.
8	5a	Route a 15-foot lashing through the front shackle on the left side.
9	6	Route a 15-foot lashing through the front shackle on the right side.
10	6a	Route a 15-foot lashing through the front shackle on the left side.

Figure 2-34. Lashings installed

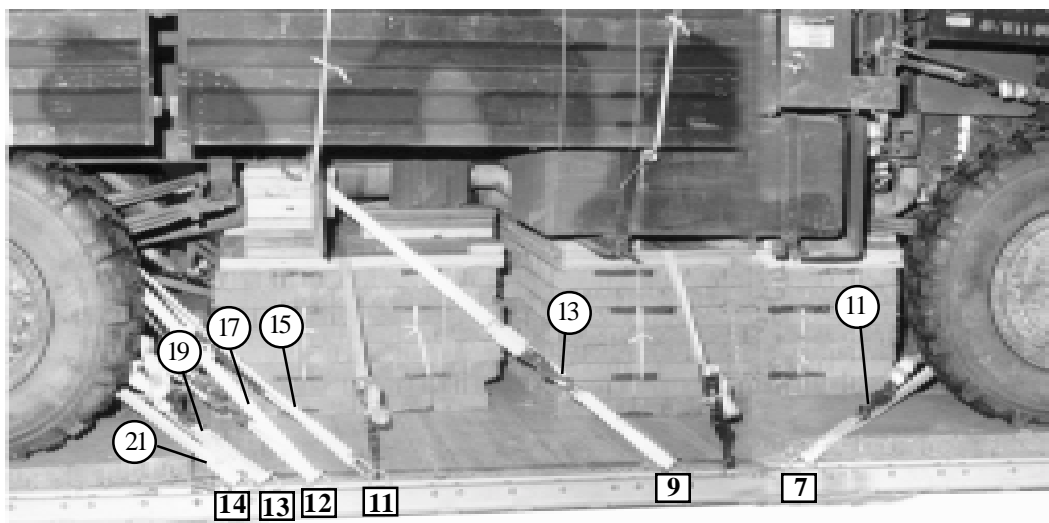

Lashing Number	Clevis Number	Instructions
11	7	Route a 15-foot lashing around the front axle, right side.
12	7a	Route a 15-foot lashing around the front axle, left side.
13	9	Route a 15-foot lashing through tiedown point #1 on the right side.
14	9a	Route a 15-foot lashing through tiedown point #1 on the left side.
15	11	Route a 15-foot lashing through tiedown point #3 on the right side.
16	11a	Route a 15-foot lashing through tiedown point #3 on the left side.
17	12	Route a 15-foot lashing through tiedown point #3 on the right side.
18	12a	Route a 15-foot lashing through tiedown point #3 on the left side.
19	13	Route a 15-foot lashing around the rear axle, right side.
20	13a	Route a 15-foot lashing around the rear axle, left side.
21	14	Route a 15-foot lashing around the rear axle, right side.
22	14a	Route a 15-foot lashing around the rear axle, left side.

Figure 2-34. Lashings installed (Continued)

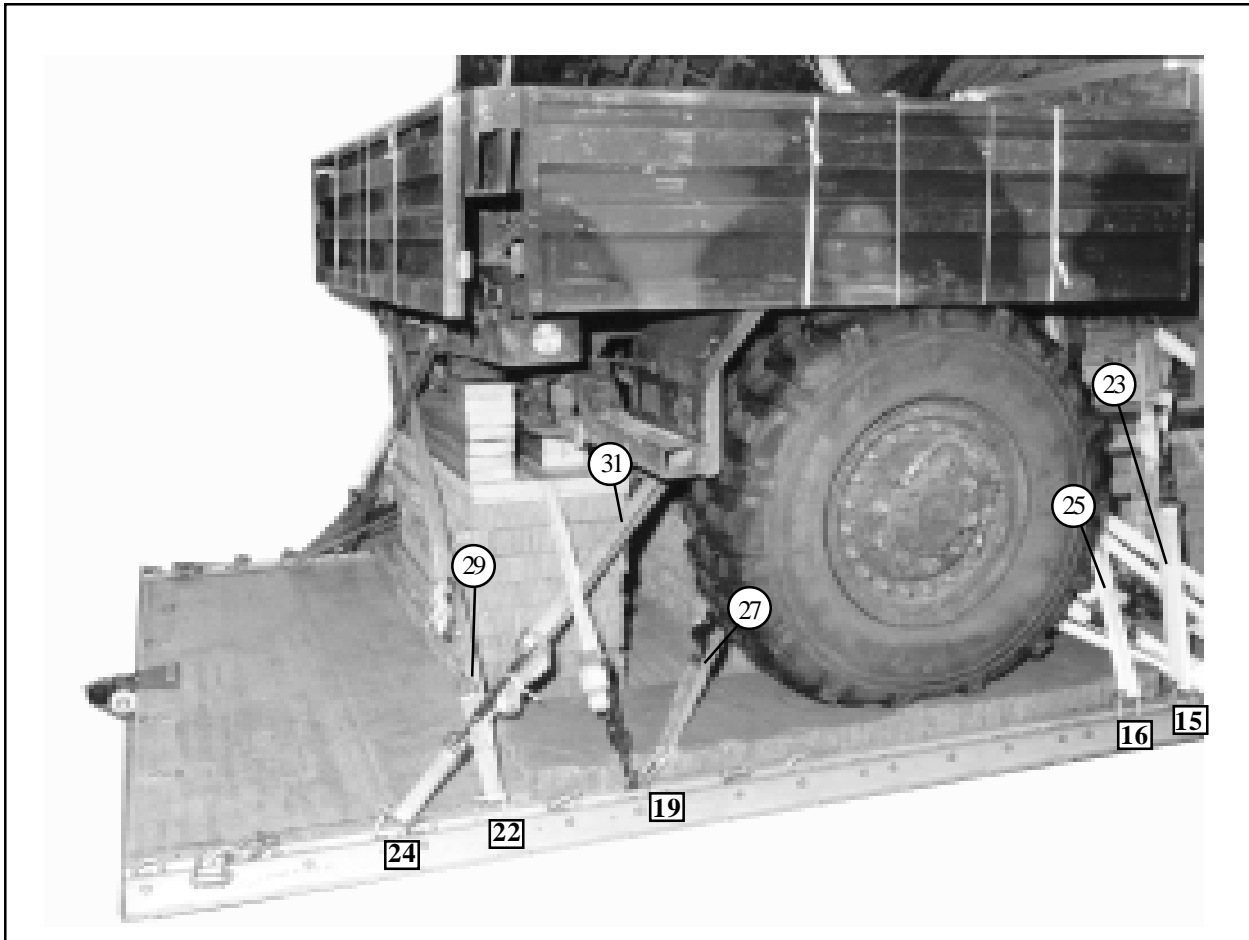

Lashing Number	Clevis Number	Instructions
23	15	Route a 15-foot lashing through tiedown point #1 on the right side.
24	15a	Route a 15-foot lashing through tiedown point #1 on the left side.
25	16	Route a 15-foot lashing through tiedown point #2 on the right side.
26	16a	Route a 15-foot lashing through tiedown point #2 on the left side.
27	19	Route a 15-foot lashing around the rear axle on the right side.
28	19a	Route a 15-foot lashing around the rear axle on the left side.
29	22	Route a 15-foot lashing through the rear shackle on the left side.
30	22a	Route a 15-foot lashing through the rear shackle on the right side.
31	24	Route a 15-foot lashing around the rear stabilizer bar on the right side.
32	24a	Route a 15-foot lashing around the rear stabilizer bar on the left side.

Figure 2-34. Lashings installed (Continued)

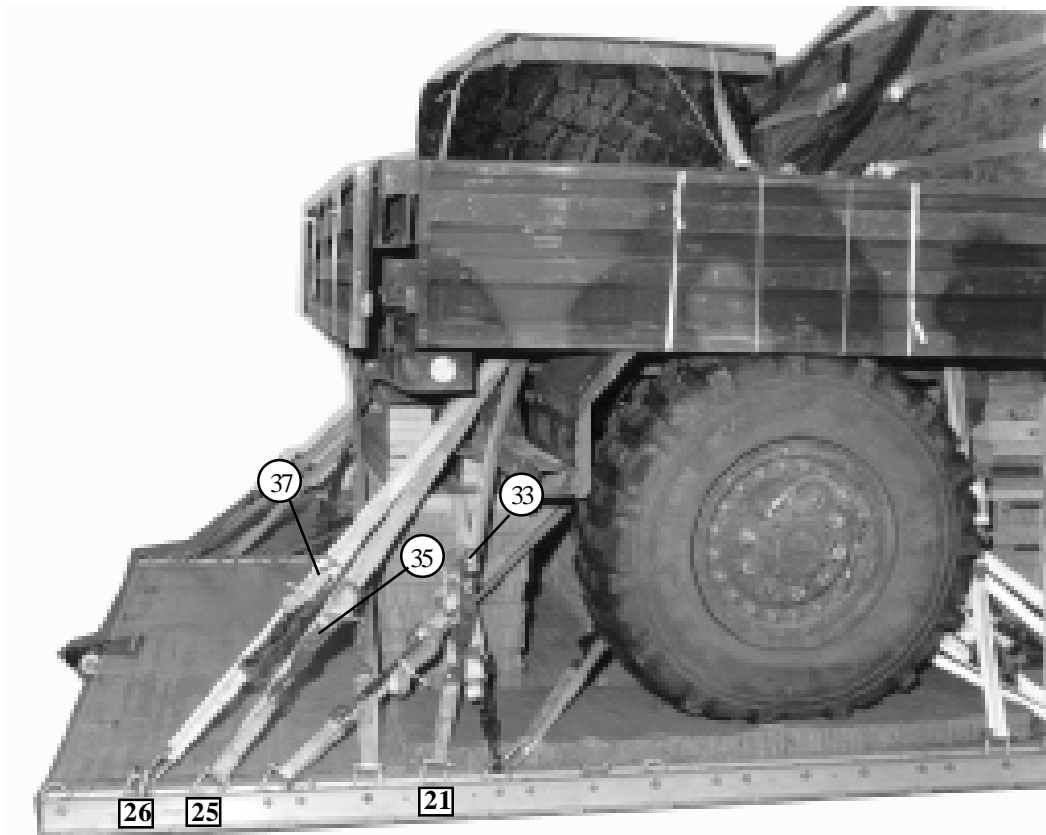

Lashing Number	Clevis Number	Instructions
33	21	Route a 15-foot lashing through tiedown point #4 on the right side.
34	21a	Route a 15-foot lashing through tiedown point #4 on the left side.
35	25	Route a 15-foot lashing through tiedown point #4 on the right side.
36	25a	Route a 15-foot lashing through tiedown point #4 on the left side.
37	26	Route a 15-foot lashing through tiedown point #4 on the right side.
38	26a	Route a 15-foot lashing through tiedown point #4 on the left side.

Figure 2-34. Lashings installed (Continued)

2-26. Installing and Safetying Suspension Slings

Install and safety two 9-foot (4-loop), two 3-foot (4-loop), type XXVI nylon slings and two 11-foot (4-loop), type XXVI nylon slings as shown in *Figure 2-35*.

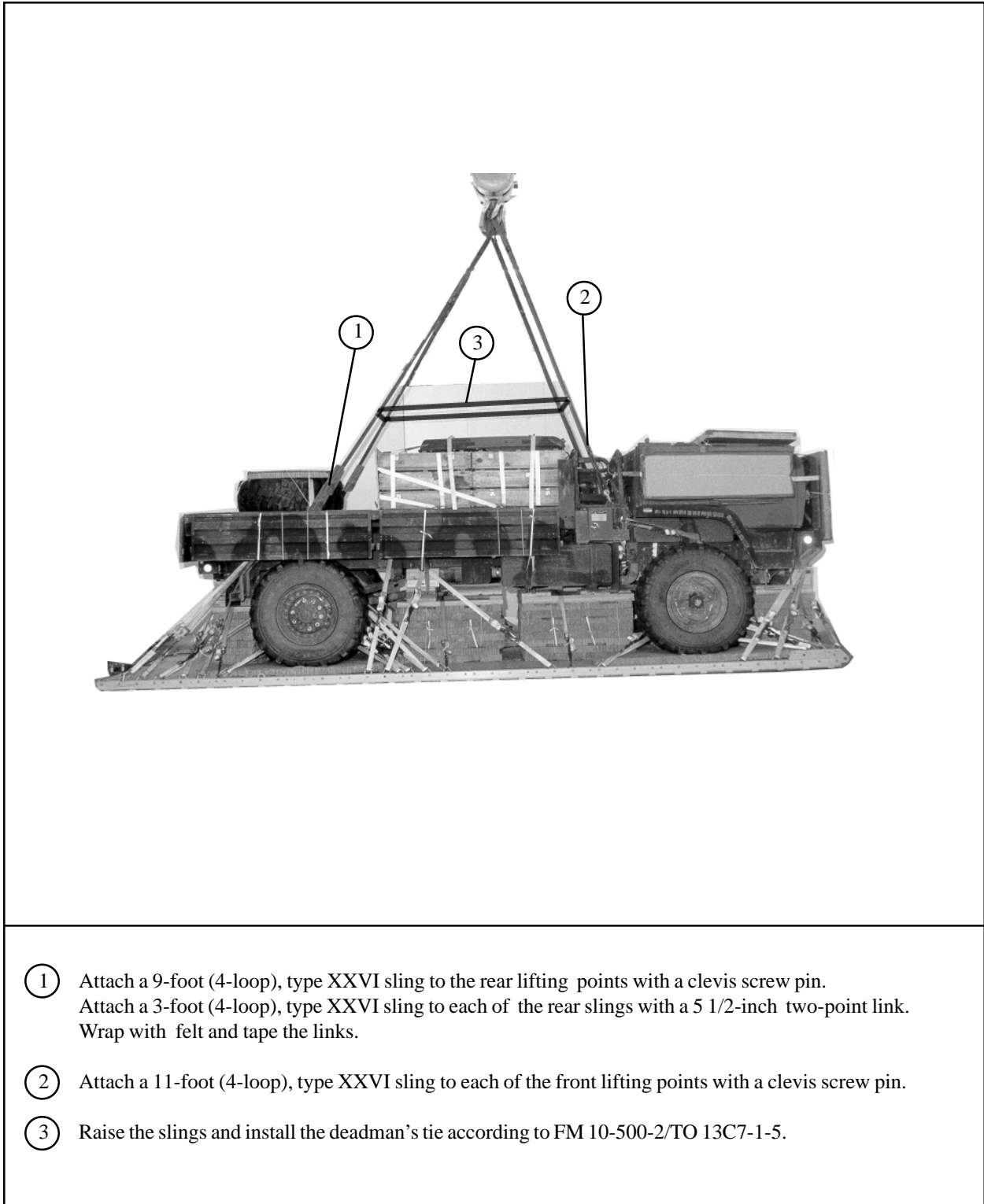

- ① Attach a 9-foot (4-loop), type XXVI sling to the rear lifting points with a clevis screw pin. Attach a 3-foot (4-loop), type XXVI sling to each of the rear slings with a 5 1/2-inch two-point link. Wrap with felt and tape the links.
- ② Attach a 11-foot (4-loop), type XXVI sling to each of the front lifting points with a clevis screw pin.
- ③ Raise the slings and install the deadman's tie according to FM 10-500-2/TO 13C7-1-5.

Figure 2-35. Suspension slings installed and safetyed

2-27. Building and Positioning the Parachute Stowage Platform

Build and position the parachute stowage platform as shown in *Figure 2-36*.

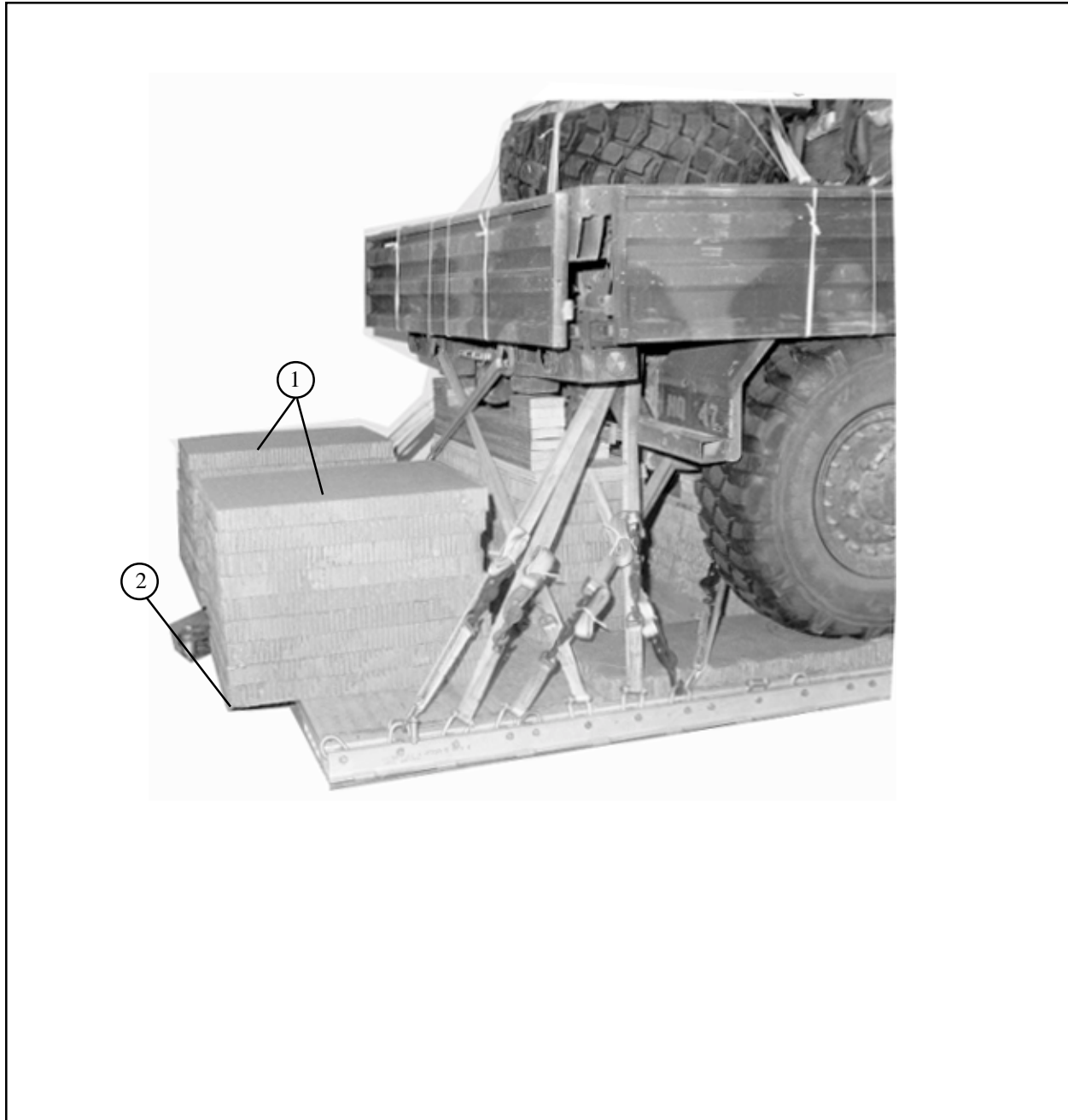

- ① Cut eighteen pieces of 24- by 36-inch honeycomb. Glue nine layers of honeycomb together forming a stack. Repeat forming the second stack.
- ② Position each stack 22-inches apart and with a 10-inch overhang. Cut a channel in the left stack so that the EFTC cable will route through it.

Figure 2-36. Cargo stowage platform positioned

Note: This drawing is not drawn to scale.

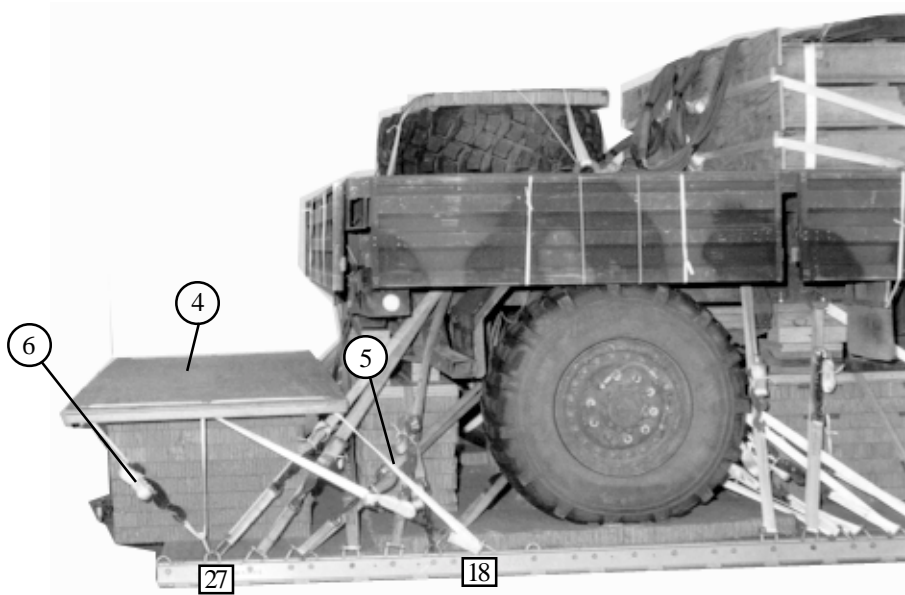
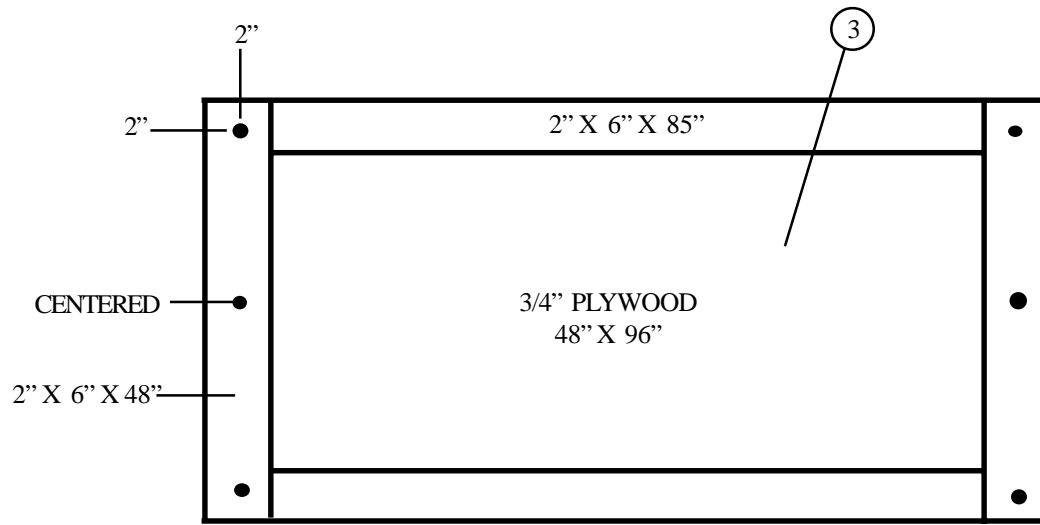

- ③ Construct a stowage platform as shown, using one sheet of 3/4-inch plywood.
- ④ Center the stowage platform on the honeycomb stacks and flush against the lashings.
- ⑤ Route a lashing through clevis 18, through the front right hole in the stowage platform, and through the center right hole. Secure with a loadbinder. Repeat using clevis 18A for the left side.
- ⑥ Route a lashing through clevis 27, through the center right hole in the stowage platform, and through the rear right hole. Secure with a loadbinder. Repeat using clevis 27A for the left side.

Figure 2-36. Cargo stowage platform positioned (Continued)

2-28. Stowing Cargo Parachutes

Stow six G-11 cargo parachutes as shown in *Figure 2-37*.

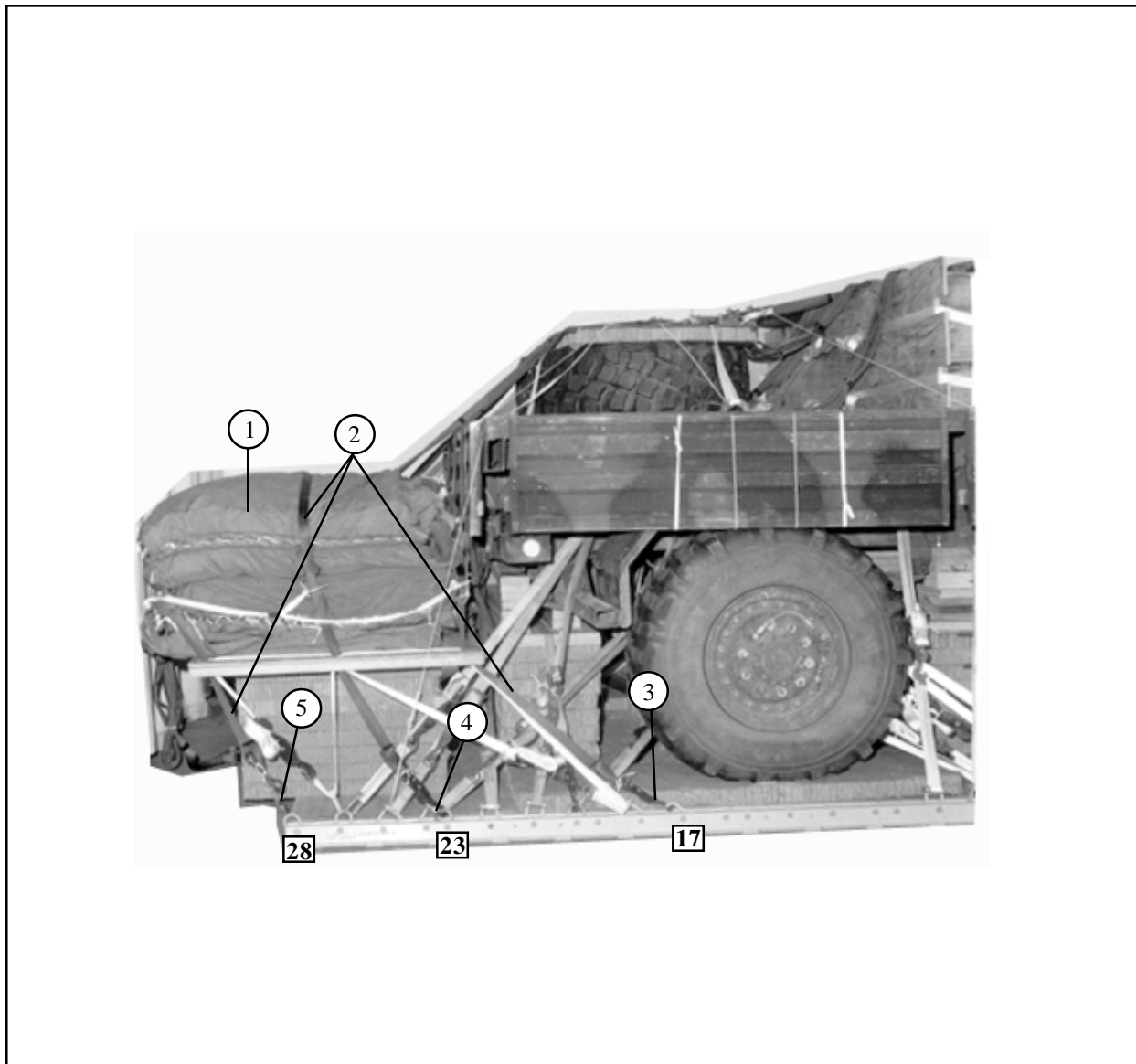

- ① Prepare, cluster and place six G-11 parachutes on the parachute stowage platform according to FM 10-500-2/TO 13C7-1-5.
- ② Install parachute restraints according to FM 10-500-2/TO 13C7-1-5.
- ③ Secure the aft restraint to clevis 17 right side. Repeat for the left side using clevis 17a.
- ④ Secure the center restraint to clevis 23 right side. Repeat for the left side using clevis 23a.
- ⑤ Secure the rear restraint to clevis 28 right side. Repeat for the left side using clevis 28a.

Figure 2-37. Cargo parachutes stowed

2-29. Installing Extraction System

Install the components of the extraction force transfer coupling (EFTC) according to FM 10-500-2/TO 13C7-1-5 and as shown in *Figure 2-38*.

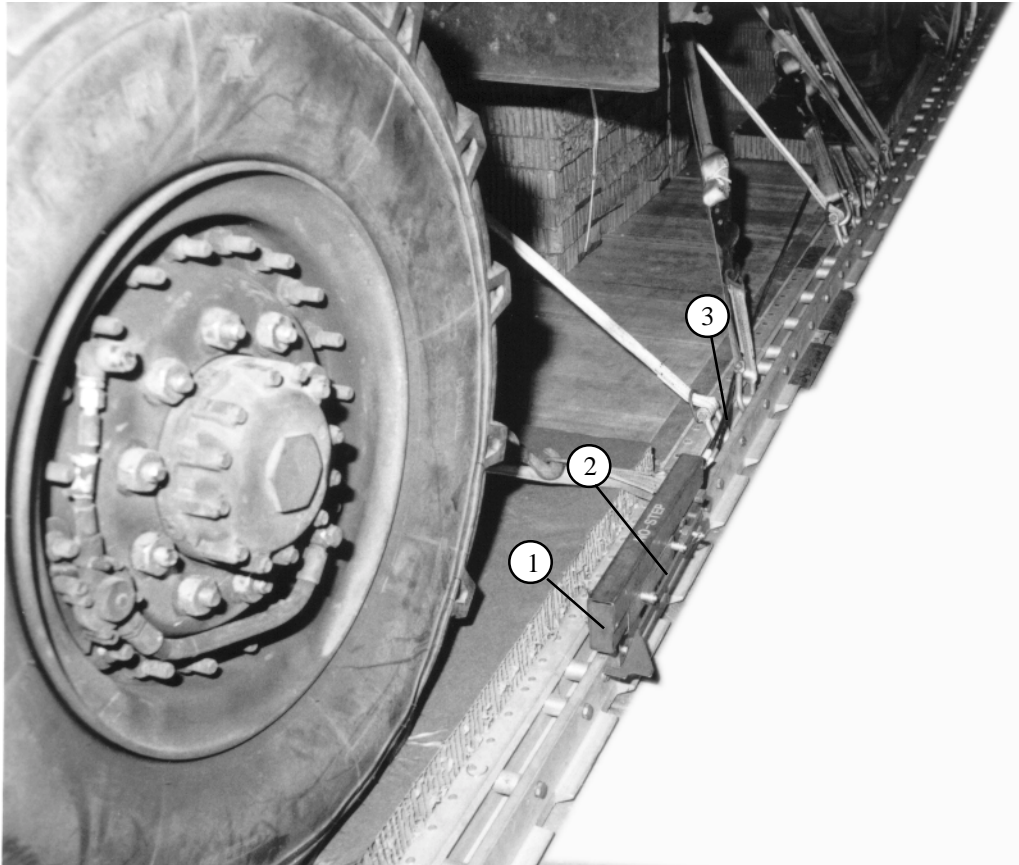

- ① Install the EFTC according to FM 10-500-2/TO 13C7-1-5.
- ② Install the EFTC mounting brackets in the rear mounting holes in the left platform rail.
- ③ Attach a 20-foot release cable to the actuator. Install the actuator in the EFTC mounting bracket.

Figure 2-38. Extraction system installed

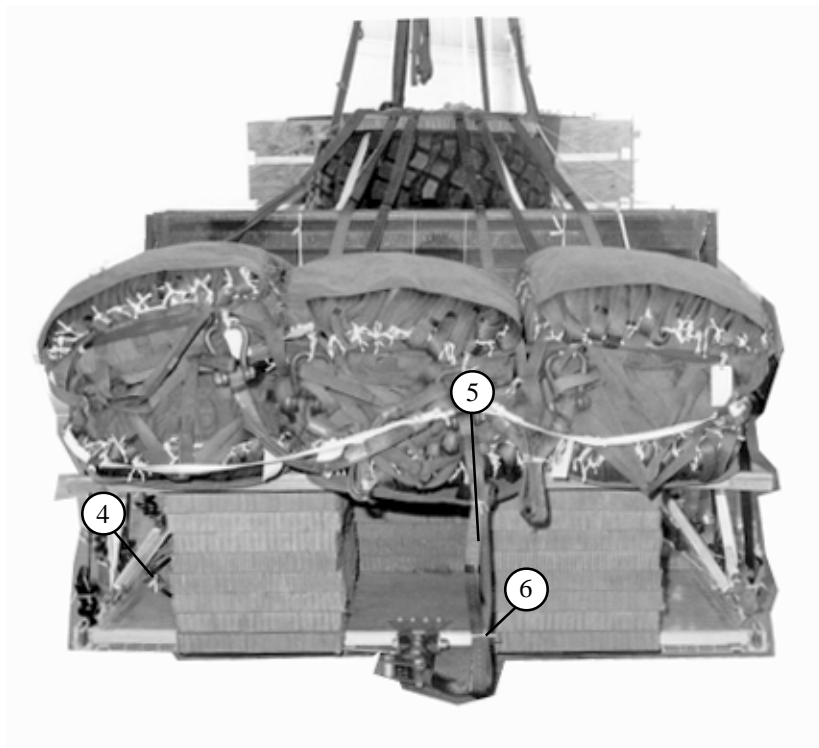

- ④ Safety the release cable with type I, 1/4-inch cotton webbing to the platform bushing or deck-rings.
- ⑤ Attach a 9-foot (2-loop), type XXXVI nylon sling, for use as a deployment line.
- ⑥ S-fold and secure the folds with type I, 1/4-inch cotton webbing according to FM 10-500-2/TO 13C7-1-5.

Figure 2-38. Extraction system installed (Continued)

2-30. Installing Release System

Install an M-2 cargo parachute release according to FM 10-500-2/TO 13C7-1-5 and as shown in *Figure 2-39*.

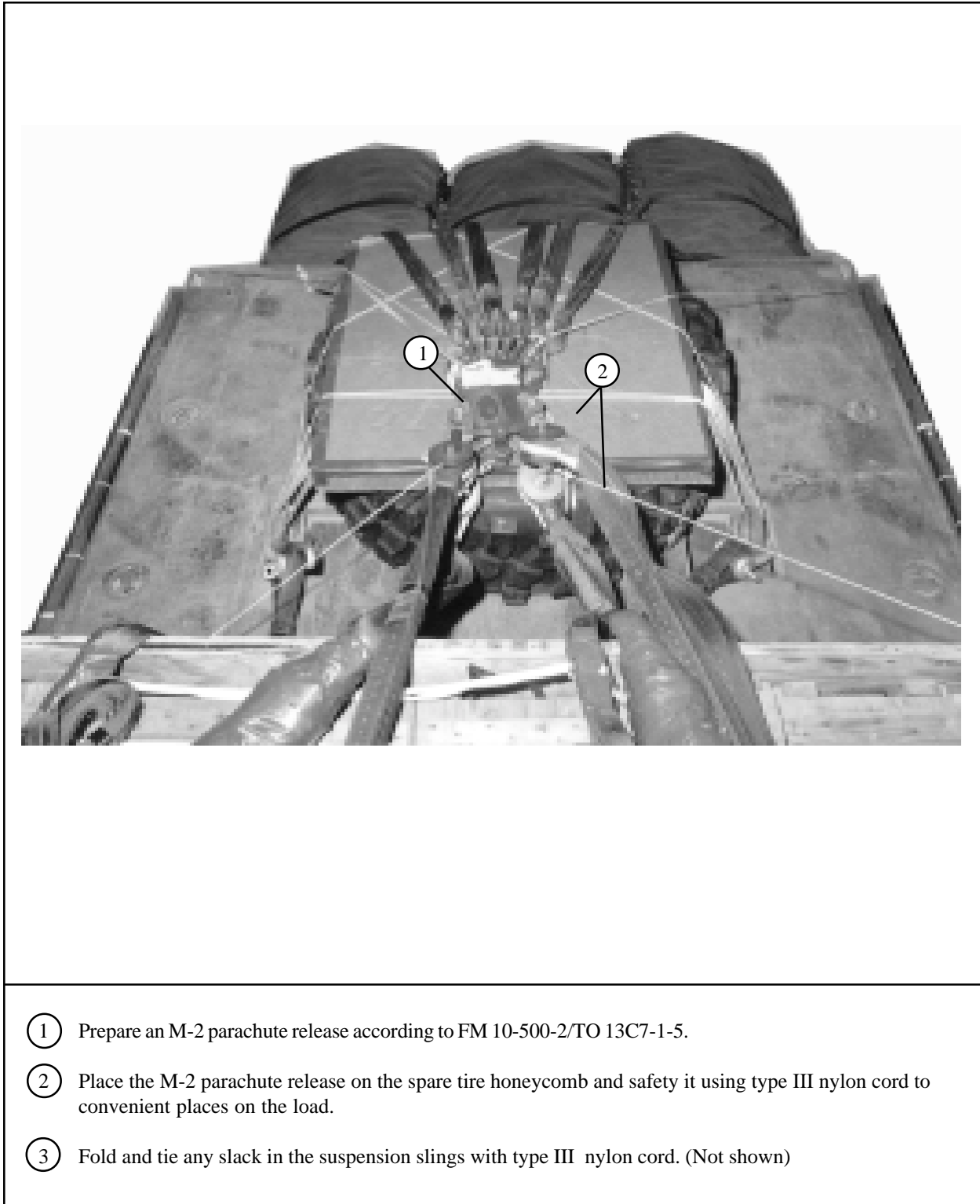

Figure 2-39. Parachute release installed

2-31. Installing Provisions for Emergency Restraints

Select and install provisions for emergency restraints according to the emergency restraint requirements table found in FM 10-500-2/TO 13C7-1-5.

2-32. Placing Extraction Parachute

Select the extraction parachute and extraction parachute line needed using the extraction parachute and extraction line requirements table found in FM 10-500-2/TO 13C7-1-5.

2-33. Marking the Rigged Load

Mark the rigged load according to FM 10-500-2/TO 13C7-1-5 and as shown in *Figure 2-40*. Complete Shipper's Declaration for Dangerous Goods and affix to load. If the load varies from the one shown, the weight, height, CB, tip-off curve and parachute requirements must be recomputed.

2-34. Equipment Required

Use the equipment listed in *Table 2-4* to rig this load.

CAUTION

Make the final rigger inspection required by
FM 10-500-2/TO 13C7-1-5 before the load leaves the rigging site.

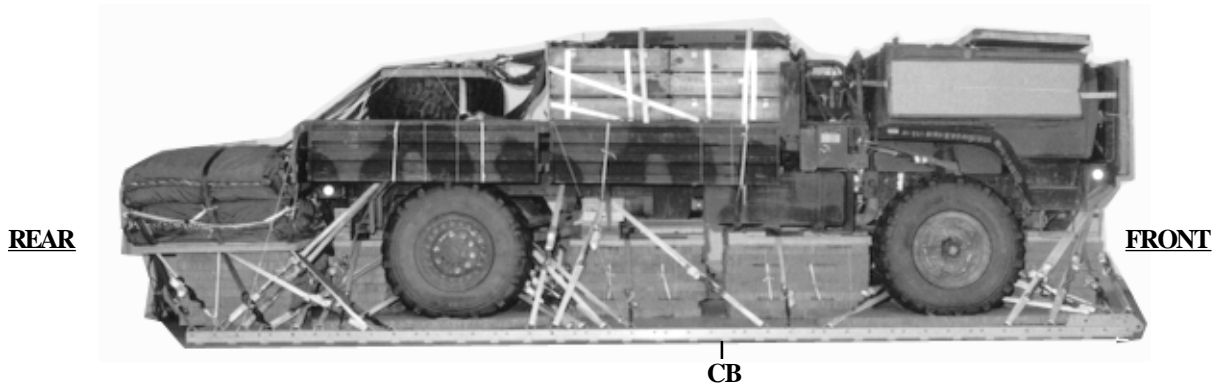

RIGGEDLOADDATA

Weight: Load shown	28,014 pounds
Minimum weight:	27,500 pounds
Maximum weight:	28,500 pounds
Height:	97 inches
Width:	108 inches
Length:	315 inches
Overhang: Front:	0 inches
Rear:	27 inches
Center of Balance: (from the front edge of the platform)	137 inches
Extraction System	EFTC

Figure 2-40. M1081, 2 1/2-ton cargo truck rigged for low-velocity airdrop

Table 2-4. Equipment required for rigging the M1081, 2 1/2-ton cargo truck for low-velocity airdrop on a type V platform

National Stock Number	Item	Quantity
8040-00-273-8713	Adhesive, paste, 1-gal	As required
N/A	Bolts, 1/2- by 10 inch, (nuts and washers)	4
1670-01-035-6054	Bridle, extraction line bag (Use with extraction line bag)	1
4030-00-432-2516	Clevis, screw pin	4
4030-00-090-5354	Clevis, suspension, 1-in (large)	8
4030-00-678-8562	Clevis, suspension, 1-in (medium)	2
4020-00-240-2164	Cord, nylon, type III, 550-lb	As required
1670-00-360-0328	Cover, clevis, large	6
1670-00-360-0329	Cover, link (type IV)	6
1670-00-434-5782	Coupling, airdrop, extraction force transfer w/20-ft cable	1
8135-00-664-6958	Cushioning material, packaging, (cellulose wadding)	As required
8305-00-958-3685	Felt, 1/2-in thick	As required
1670-01-183-2678	Leaf, extraction line	1
	Line, extraction, type XXVI nylon webbing:	
1670-01-062-6313	60-ft (6-loop), (C-130 aircraft)	1
5510-00-220-6148	60-ft (1-loop), drogue	1
1670-01-220-6248	120-ft (6-loop), (dual parachutes), (C-141, C-5 aircraft)	1
1670-01-468-9178	140-ft (6-loop), (C-17 aircraft)	1
	Truck preparation Lumber:	
5510-00-220-6146	2- by 4- by 6	2
5510-00-220-6148	2- by 6- by 6	1
	2- by 6- by 13	1
5510-00-220-6274	4- by 4- by 6	2
	4- by 4- by 15	2

Table 2-4. Equipment required for rigging the M1081, 2 1/2-ton cargo truck for low-velocity airdrop on type V platform (continued)

National Stock Number	Item	Quantity
1670-00-006-2752	Link assembly: Four-point:	1
	Two-point:	
5305-00-435-8994	Bolt, 1-in diam, 4-in long	(2)
5310-00-232-5165	Nut, 1-in	(2)
1670-00-003-1954	Plate, side, 5 1/2-in	(2)
5365-00-007-3414	Spacer, large	(2)
1670-00-783-5988	Type IV	6
1670-01-247-2389	Link, suspension tandem	2
	Load spreader for honeycomb stack 1:	
5510-00-220-6246	Lumber:	
	2- by 8- by 12-in	4
	2- by 8- by 43-in	3
5510-00-220-6448	Plywood 3/4-in:	
	7- by 14-in	4
	7 1/2- by 12-in	4
	24- by 43	3

Table 2-4. Equipment required for rigging the M1081, 2 1/2-ton cargo truck for low-velocity airdrop on a type V platform (continued)

National Stock Number	Item	Quantity
	Load spreader for honeycomb stack 2:	
5510-00-220-6148	Lumber, 2- by 6- by 18-in	2
5530-00-128-4981	Plywood, 3/4-in:	
	5 1/2- by 18-in	2
	18- by 48-in	2
	Load spreader for honeycomb stack 3:	
5510-00-220-6246	Lumber, 2- by 8- by 26 1/2-in	2
5530-00-129-7777	Plywood, 1/2-in:	
	7 1/2- by 26 1/2-in	1
5510-00-128-4981	Plywood, 3/4-in:	
	6- by 8-in	1
	7 1/2- by 8-in	2
	8- by 16-in	1
	10- by 10-in	1
	12- by 14-in	4
	46- by 48-in	4
	Load spreader for honeycomb stack 4:	
	Lumber:	
5510-00-220-6148	2- by 6- by 21-in	6
	2- by 6- by 48-in	1
5510-00-220-6250	2- by 12- by 12-in	4
	2- by 12- by 34- in	2
5510-00-220-6448	Plywood 3/4-in:	
	11 1/2- by 12-in	4
	44- by 48-in	3

Table 2-4. Equipment required for rigging the M1081, 2 1/2-ton cargo truck for low-velocity on type V airdrop platform (continued)

National Stock Number	Item	Quantity
	Load spreader for honeycomb stack 5:	
5510-00-220-6148	Lumber, 2- by 6- by 18-in	2
5530-00-128-4981	Plywood, 3/4-in:	
	5 1/2- by 18-in	6
	18- by 60-in	2
	Load spreader for honeycomb stack 6:	
	Lumber:	
5510-00-220-6148	2- by 6- by 8-in	6
	2- by 6- by 33-in	3
	2- by 6- by 45-in	4
5530-00-128-4981	Plywood, 3/4-in:	
	18- by 48-in	3
	Nail, steel wire, common:	
5315-00-010-4659	8d	As required
5315-00-753-3885	16d	As required
1670-00-753-3928	Pad, energy-dissipating, honeycomb,	
	3- by 36- by 96-in:	40 sheets
	4- by 6-in	1
	12- by 30-in	1
	12- by 31-in	12
	18- by 44-in	24
	18- by 48-in	13
	18- by 60-in	2
	24- by 34-in	4
	36- by 44-in	4
	36- by 80-in	1
	36- by 96-in	10
	43- by 20-in	5
	74- by 18-in	2
	43- by 30-in	2
	96- by 18-in	2

Table 2-4. Equipment required for rigging the M1081, 2 1/2-ton cargo truck for low-velocity airdrop on a type V platform (continued)

National Stock Number	Item	Quantity
1670-01-016-7841	Parachute, cargo: G-11C	6
1670-00-040-8135	Parachute, cargo extraction: 28-ft	2
1670-01-063-3715	15-ft	1
1670-01-353-8425	Platform, AD, type V, 24-ft Bracket assembly comp	1 (1)
1670-01-162-2372	Clevis, load tiedown	(56)
1670-01-353-8424	Extraction bracket assembly	(1)
1670-01-162-2381	Tandem link	(2)
1670-01-097-8817	Release, cargo parachute, M-2	1
1670-01-062-6304	Sling, cargo, airdrop: For deployment line: 9-ft (2-loop), type XXVI nylon webbing	1
1670-01-062-6306	For lifting and suspension: 3-ft (4-loop), type XXVI nylon webbing	2
1670-01-062-6305	9-ft (4-loop), type XXVI nylon webbing	2
1670-01-062-6310	11-ft (4-loop), type XXVI nylon webbing	2
1670-01-062-6311	For riser extention: 120-ft (2-loop), type XXVI nylon webbing	6

Table 2-4. Equipment required for rigging the M1081, 2 1/2-ton cargo truck for low-velocity airdrop on a type V platform (continued)

National Stock Number	Item	Quantity
5340-00-040-8219	Strap, parachute release, multi-cut with 3 knives	2
7510-00-266-5012	Tape, adhesive, 2-in (masking)	As required
7510-00-079-7906	Tape, adhesive, 2-in (pressure sensitive)	As required
1670-00-937-0271	Tiedown assembly, 15-ft	73
	Webbing:	
8305-00-268-2411	Cotton, 80-lb	As required
8305-00-082-5752	Nylon, tubular, 1/2-in, 1,000-lb natural	As required
8305-00-263-3591	Type VIII	As required

CHAPTER 3

RIGGING M1093, 5-TON 6x6 STANDARD CARGO TRUCK ON A 28-FOOT TYPE V PLATFORM FOR LOW-VELOCITY AIRDROP

RIGGING M1093, 5-TON CARGO TRUCK WITH BASIC LOAD

3-1. Description of Load

The M1093, 5-ton cargo truck (*Figure 3-1*) is rigged on a 28-foot, type V airdrop platform with six G-11 cargo parachutes and other items of airdrop equipment.

The load consists of the M1093, 5-ton cargo truck and basic load. This load is 100 inches in height, 108 inches in width, 354 inches in length and has a rigged weight of 27,318 pounds.

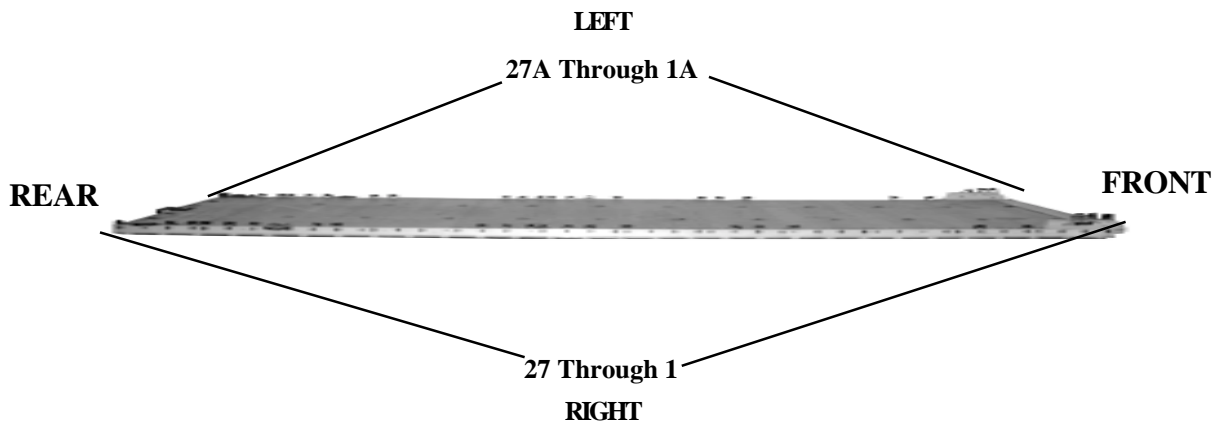

Figure 3-1. M1093, 5-ton 6x6 standard cargo truck

3-2. Preparing Platform

Prepare a 28-foot, type V platform as described below and as shown in *Figure 3-2*.

- NOTES:**
1. The nose bumper may or may not be installed.
 2. Measurements given in this section are from the front edge of the platform NOT from the front edge of the nose bumper.



Step:

1. Inspect, or assemble and inspect, a 28-foot, type V airdrop platform as outlined in TM 10-1670-268-20&P/ TO 13C7-52-22.
2. Install a tandem link on the front of each platform side rail using holes 1, 2, and 3.
3. Attach clevises to each tandem link using bushings 1, 2, and 3 (tripled).
4. Starting at the front of each platform side rail, install clevises using bushings bolted to holes 7, 10, 12, 13, 21, 22, 23, 24, 25, 26, 27, 29, 30, 31, 42, 43, 45, 46, 47, 48, 49, 52 and 56.
5. Starting at the front of the platform, number the clevises bolted to the right rail 1 through 27 and the left rail 1A through 27A.

Figure 3-2. Platform Prepared

3-3. Preparing Honeycomb Stacks

Use the material in *Table 3-1* to prepare 10 honeycomb stacks as shown in *Figures 3-3 through 3-10*.

Table 3-1. Material needed to build honeycomb stacks

Stack Number	Pieces	Width (Inches)	Length (Inches)	Material	Instructions
1	7	48	18	Honeycomb	See <i>Figure 3-3</i> .
	3	48	18	3/4-inch plywood	
	4	2- by 6	45	Lumber	
	10	2- by 6	8	Lumber	
	3	2- by 6	33	Lumber	
	4	2- by 6	10	Lumber	
	4	8	5 1/2	1/2-inch plywood	
	1	10	5 1/2	1/2-inch plywood	
2	5	43	20	Honeycomb	See <i>Figure 3-4</i> .
	3	43	20	3/4-inch plywood	
	3	2- by 8	20	Lumber	
	1	7 1/2	20	3/4-inch plywood	
3	5	48	18	Honeycomb	See <i>Figure 3-5</i> .
	3	48	18	3/4-inch plywood	
	2	4- by 4	48	Lumber	
	2	2- by 4	11	Lumber	
	2	11	6	3/4-inch plywood	
4	2	36	44	Honeycomb	See <i>Figure 3-6</i> .
	2	12	44	Honeycomb	
	12	18	44	Honeycomb	
	6	12	36	Honeycomb	
	3	48	44	3/4-inch plywood	
	1	2- by 6	48	Lumber	
	2	2- by 6	21	Lumber	
	3	2- by 6	21	Lumber	
	2	5 1/2	21	3/4-inch plywood	
	4	2- by 12	12	Lumber	
	2	12	11 1/2	3/4-inch plywood	
	2	2- by 12	38 1/2	Lumber	

Table 3-1. Material needed to build honeycomb stacks (continued)

Stack Number	Pieces	Width (Inches)	Length (Inches)	Material	Instructions
5	2	36	46	Honeycomb	See Figure 3-7.
	2	12	46	Honeycomb	
	12	18	46	Honeycomb	
	6	12	36	Honeycomb	
	3	48	46	3/4-inch plywood	
	6	14	12	3/4-inch plywood	
	2	2- by 8	26 1/2	Lumber	
	1	7 1/2	26 1/2	3/4-inch plywood	
	1	7 1/2	8	3/4-inch plywood	
	1	10	10	3/4-inch plywood	
	1	8	6	3/4-inch plywood	
1	8	16	3/4-inch plywood		
6	8	43	24	Honeycomb	See Figure 3-8.
	3	43	24	3/4-inch plywood	
	3	2- by 8	43	Lumber	
	4	2- by 8	12	Lumber	
	4	7 1/2	12	3/4-inch plywood	
	4	14	7	3/4-inch plywood	
7	1	18	96	Honeycomb	See Figure 3-9.
8	1	18	96	Honeycomb	See Figure 3-9.
9	1	18	74	Honeycomb	See Figure 3-10.
10	1	18	74	Honeycomb	See Figure 3-10.

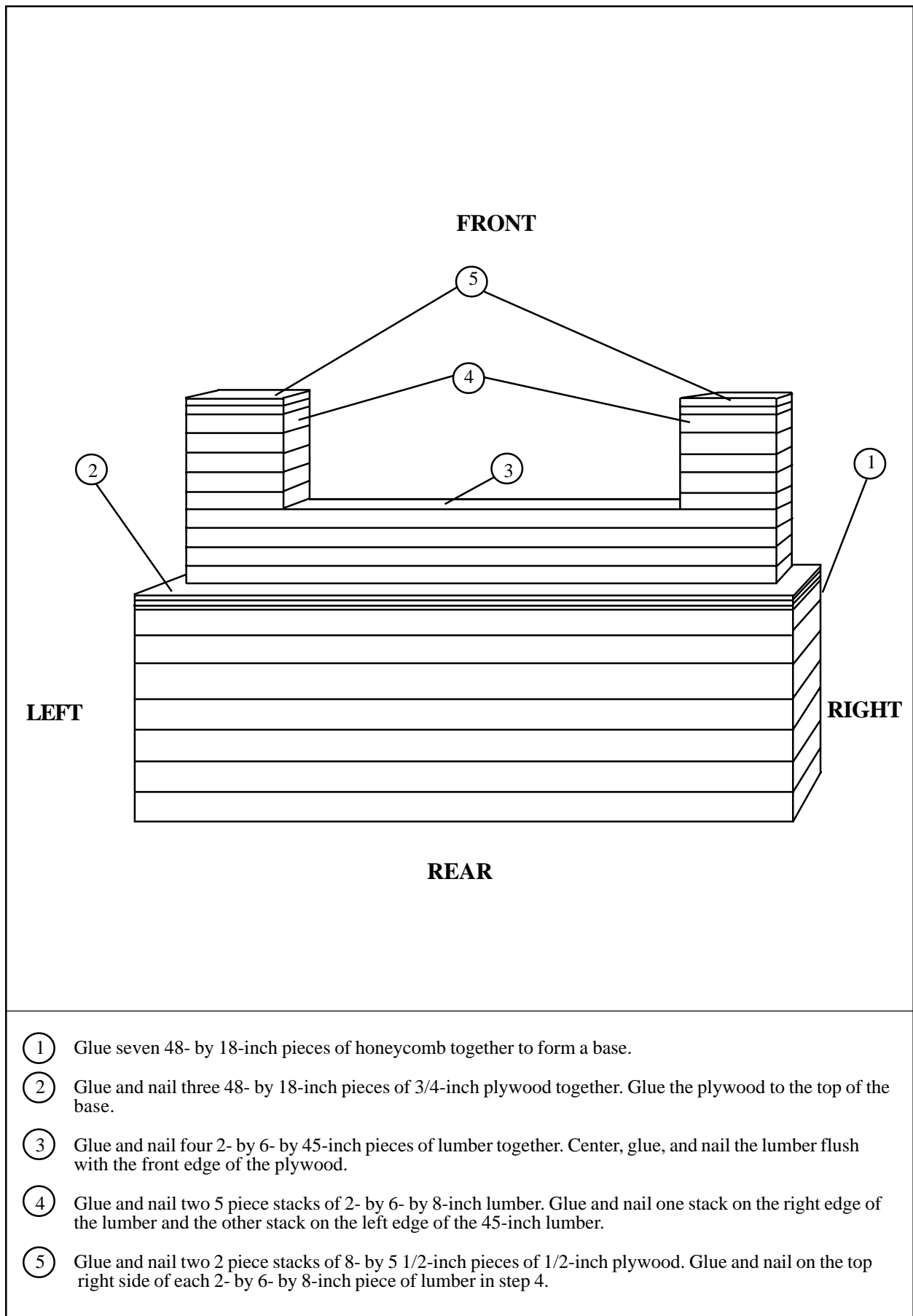

- ① Glue seven 48- by 18-inch pieces of honeycomb together to form a base.
- ② Glue and nail three 48- by 18-inch pieces of 3/4-inch plywood together. Glue the plywood to the top of the base.
- ③ Glue and nail four 2- by 6- by 45-inch pieces of lumber together. Center, glue, and nail the lumber flush with the front edge of the plywood.
- ④ Glue and nail two 5 piece stacks of 2- by 6- by 8-inch lumber. Glue and nail one stack on the right edge of the lumber and the other stack on the left edge of the 45-inch lumber.
- ⑤ Glue and nail two 2 piece stacks of 8- by 5 1/2-inch pieces of 1/2-inch plywood. Glue and nail on the top right side of each 2- by 6- by 8-inch piece of lumber in step 4.

Figure 3-3. Stack 1 prepared

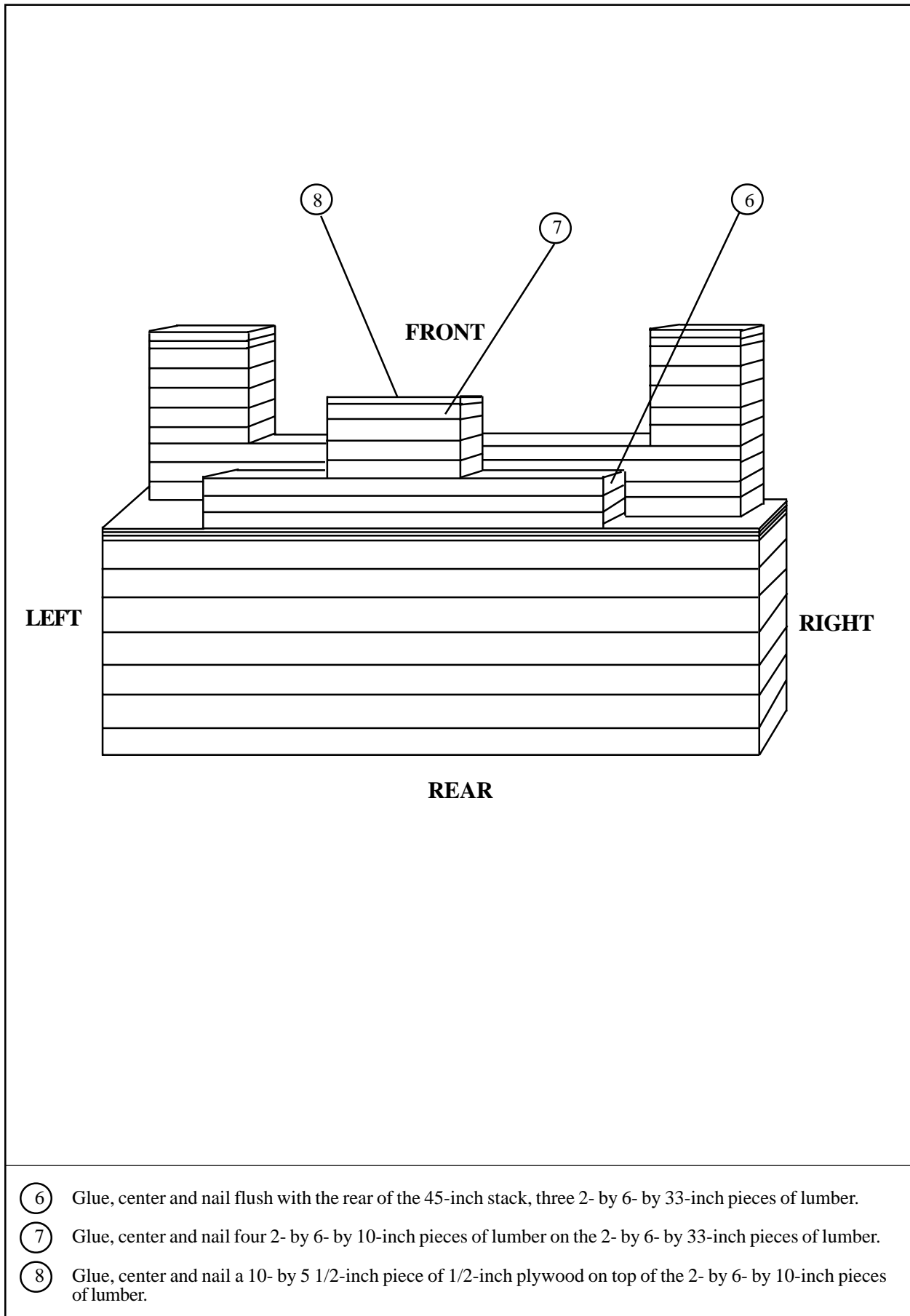

Figure 3-3. Stack 1 prepared (Continued)

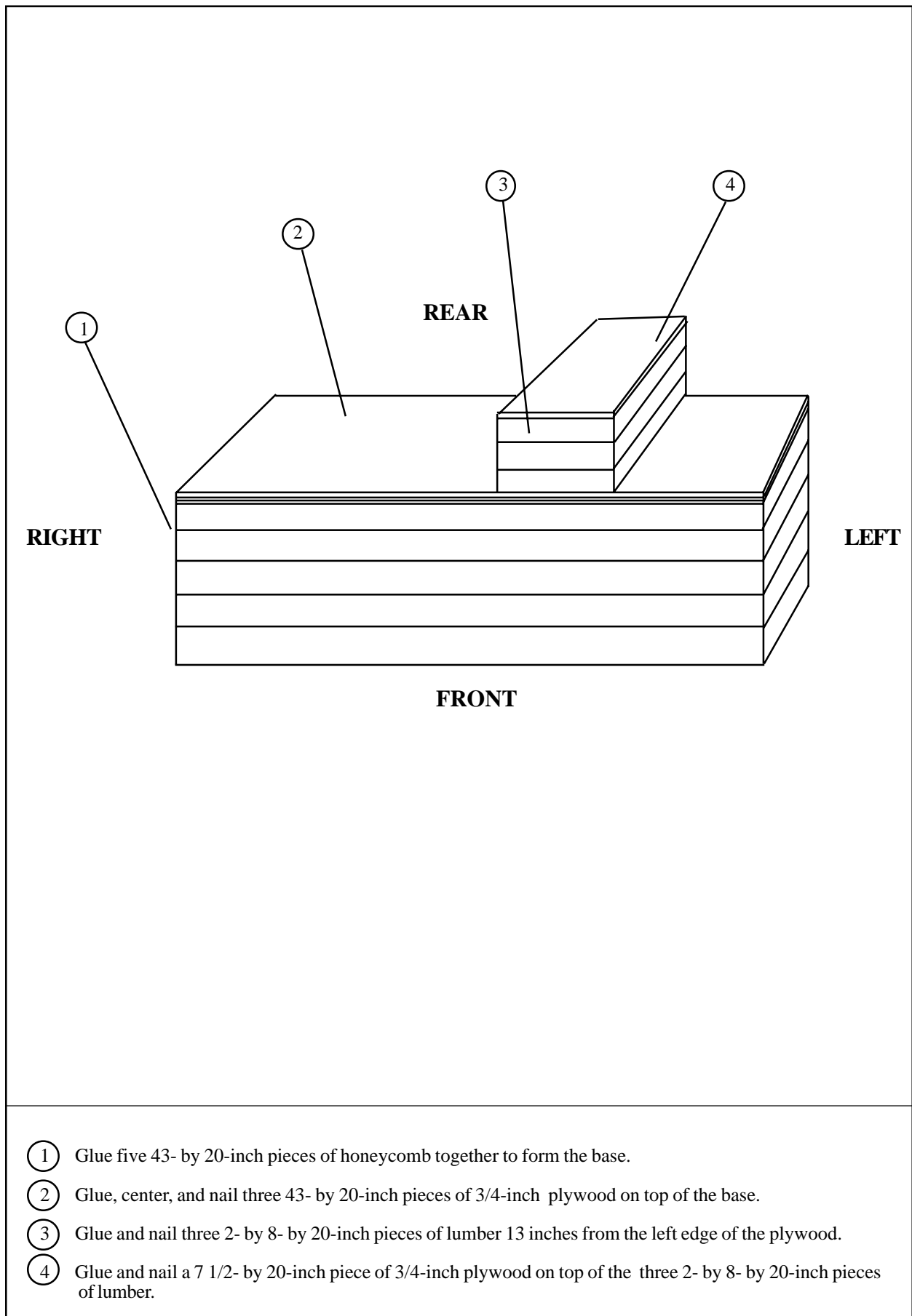

Figure 3-4. Stack 2 prepared

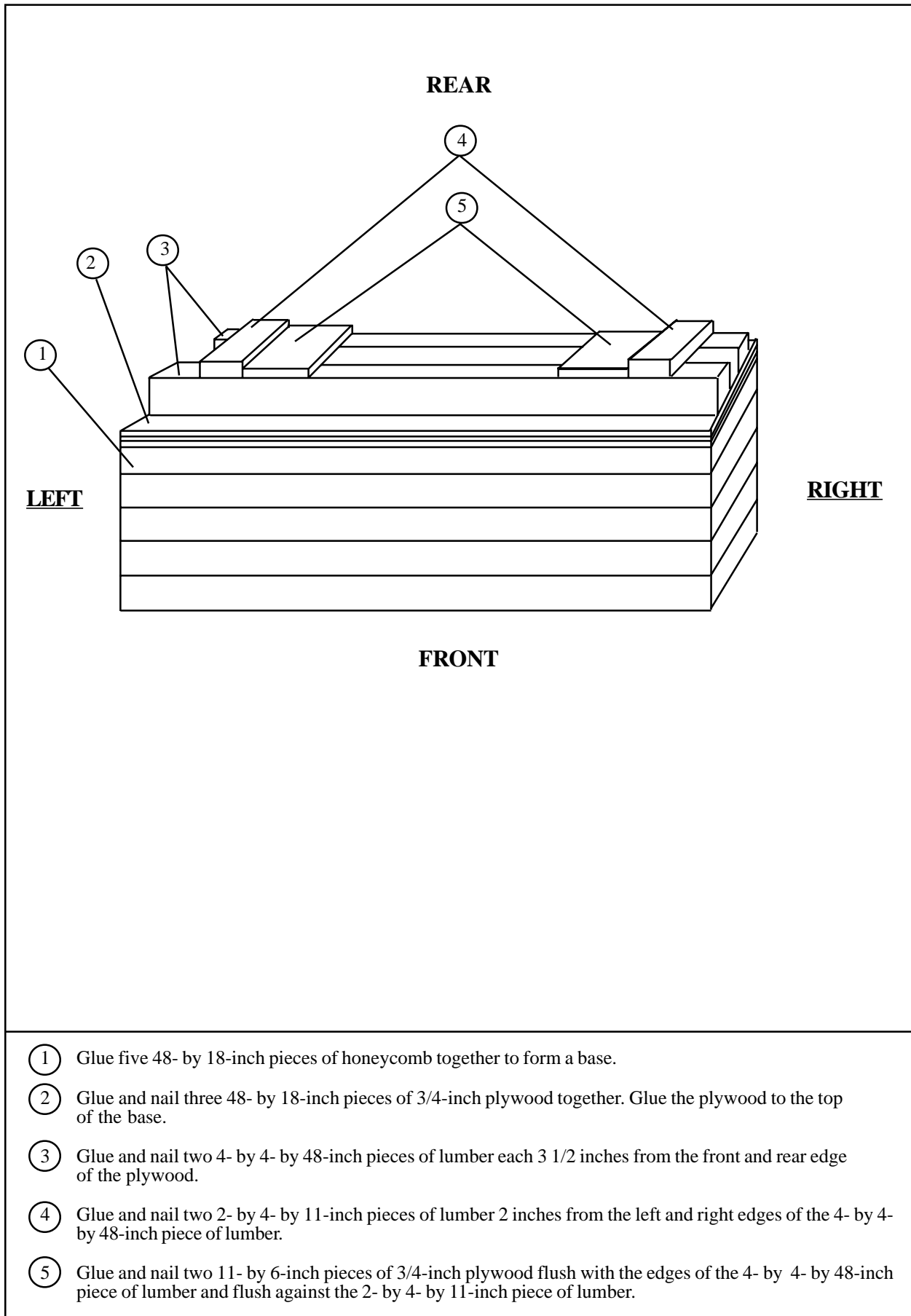
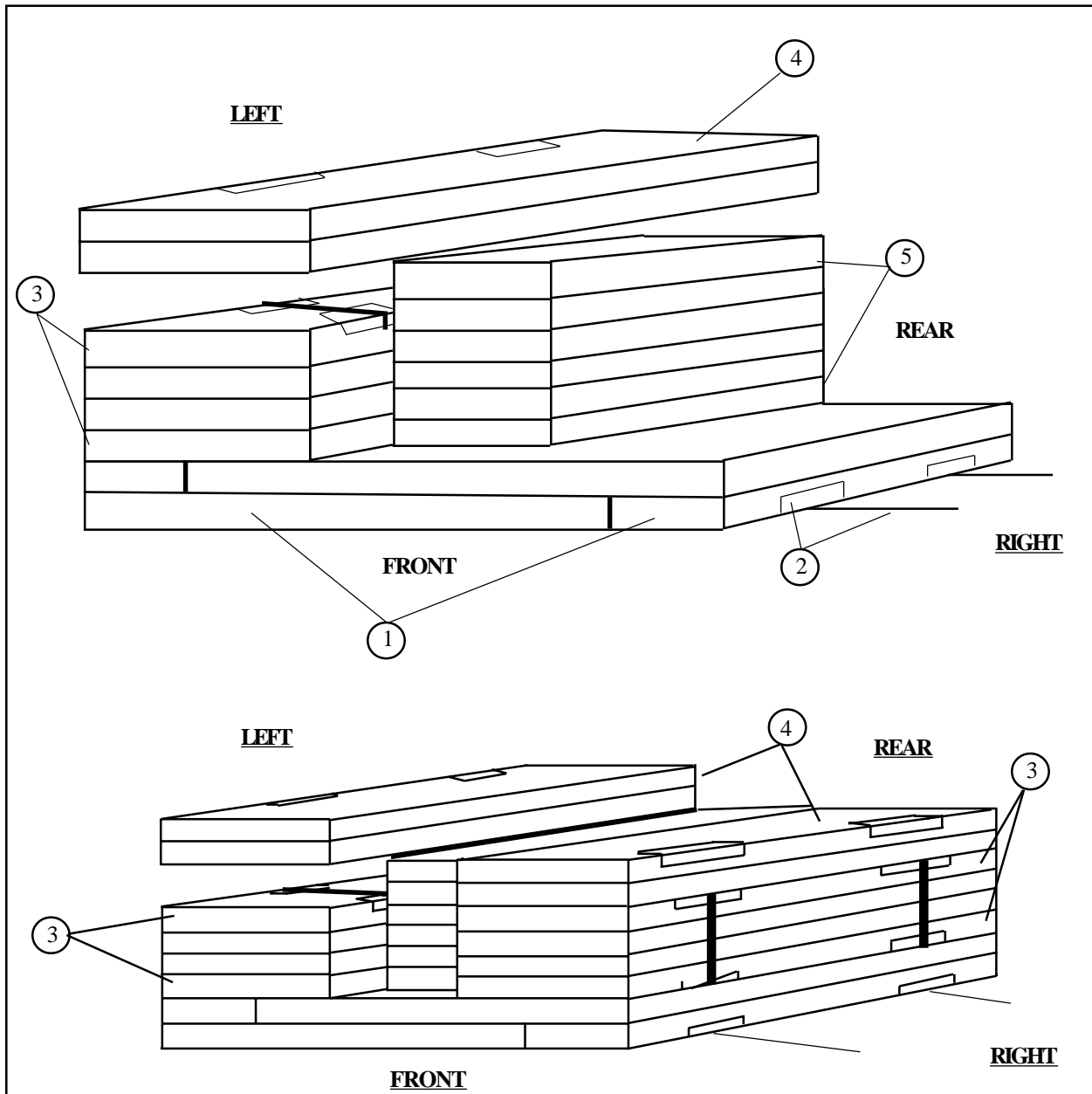

Figure 3-5. Stack 3 prepared



- ① Position a 36- by 44-inch piece of honeycomb beside a 12- by 44-inch piece of honeycomb. Glue a 36- by 44-inch piece of honeycomb and a 12- by 44-inch piece of honeycomb on top of the first layer. Alternate them to form the base.
- ② Place a length of cloth backed tape on the bottom outer edges of the base. Position two 13-foot lengths of type III nylon cord under the base aligned with the strips of tape.
- ③ Form two stacks by gluing four pieces of 18- by 44-inch honeycomb together. Place a sufficient length of cloth backed tape on all edges. Run a length of 1/2-inch tubular nylon over the strips of tape and around the stack. Secure and tie with a square knot on the outside of the stack. Place the stack flush with the base. **(Do not glue to base.) (The 1/2-inch tubular nylon ties, PULL-OUT AIDS, are to assist in pulling the stacks out from under the vehicle during derigging.)**
- ④ Form two stacks by gluing two pieces of 18- by 44-inch honeycomb together. Place a length of cloth backed tape on each end. Position each stack on top of the existing stacks. **(Do not glue.)**
- ⑤ Form a stack by gluing six 12- by 36-inch pieces of honeycomb together. Position the stack between the two stacks in step 4, flush with the rear edge of the base. **(Do not glue to base.)**

Figure 3-6. Stack 4 prepared

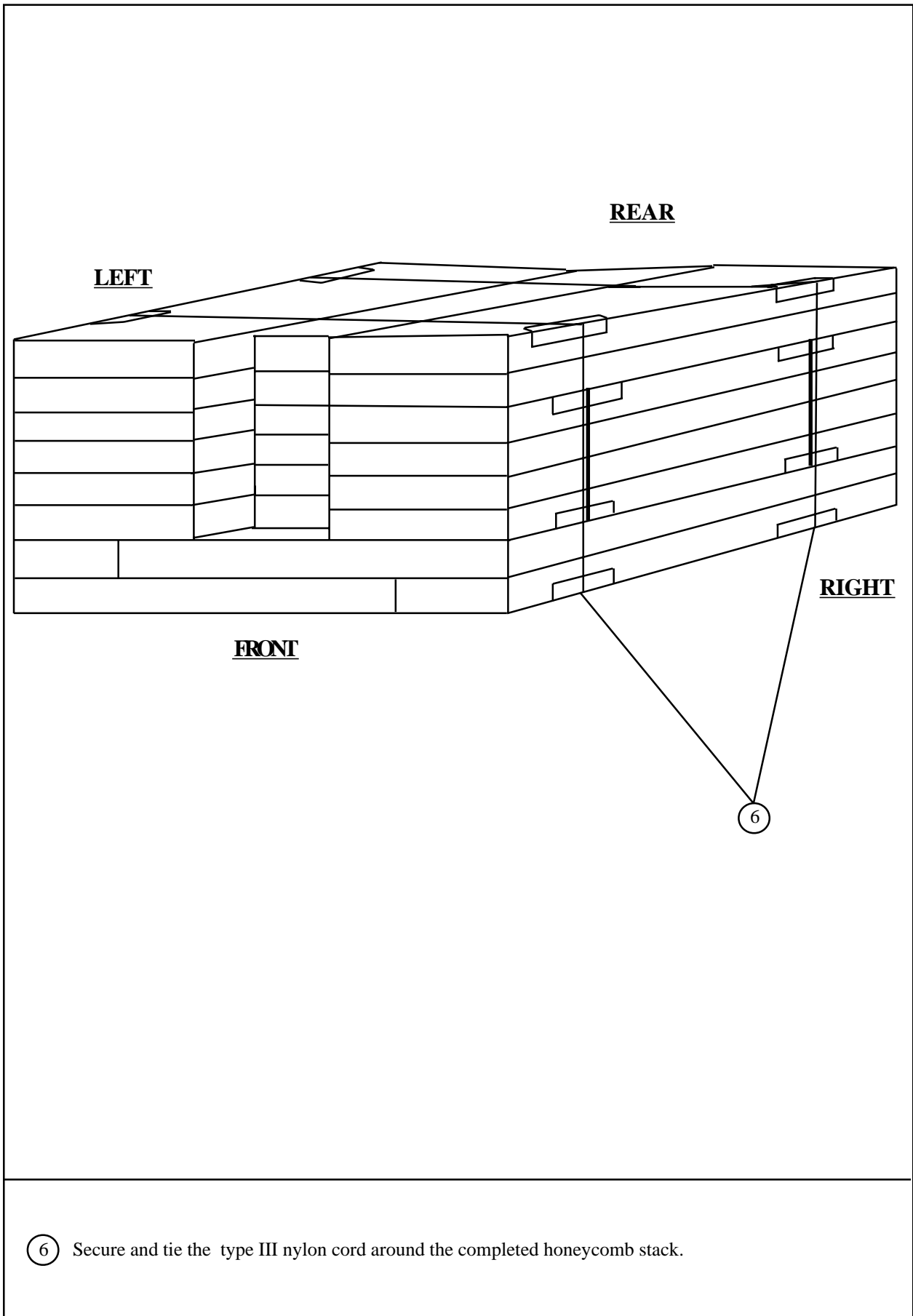

Figure 3-6. Stack 4 prepared (Continued)

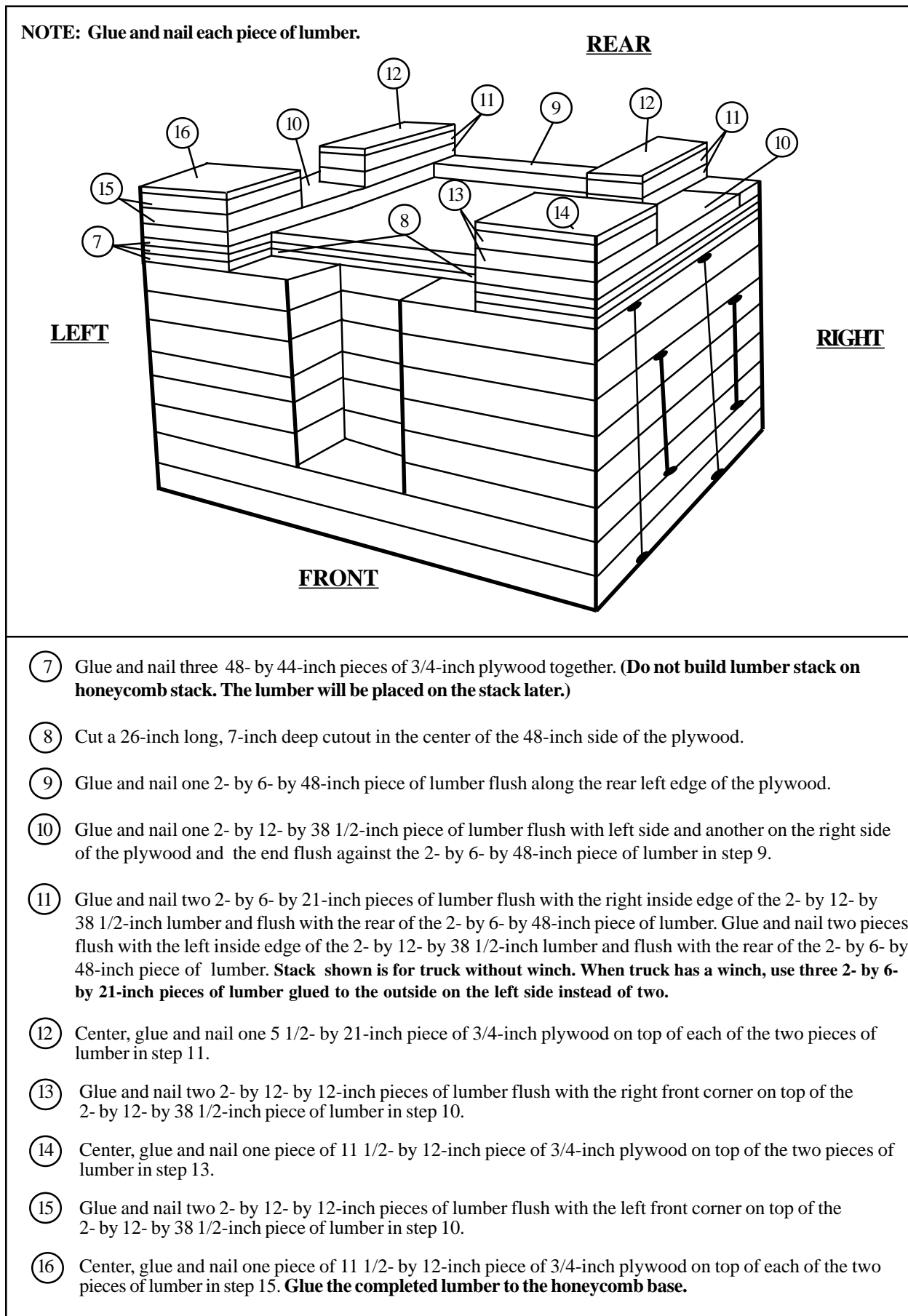
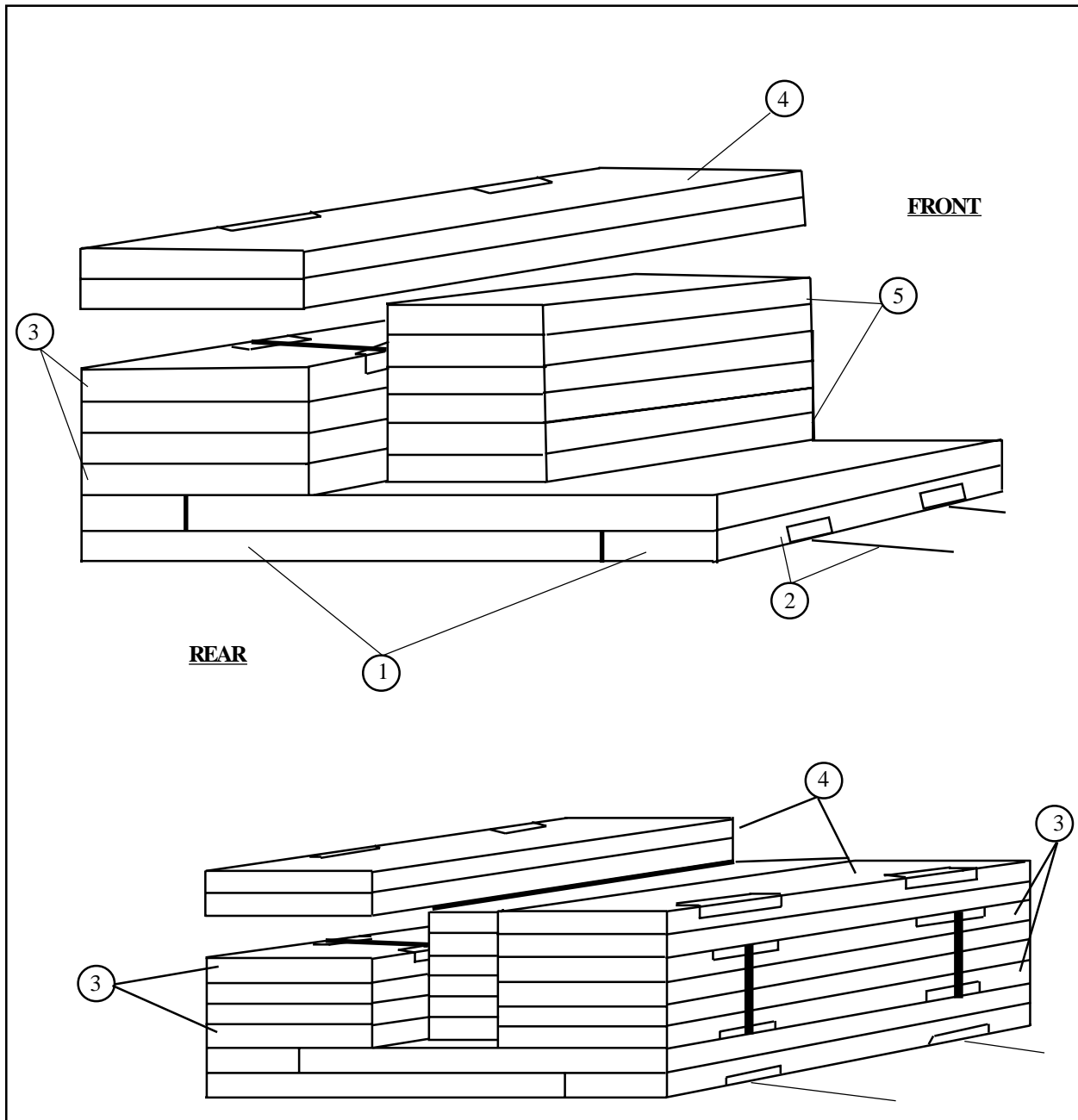
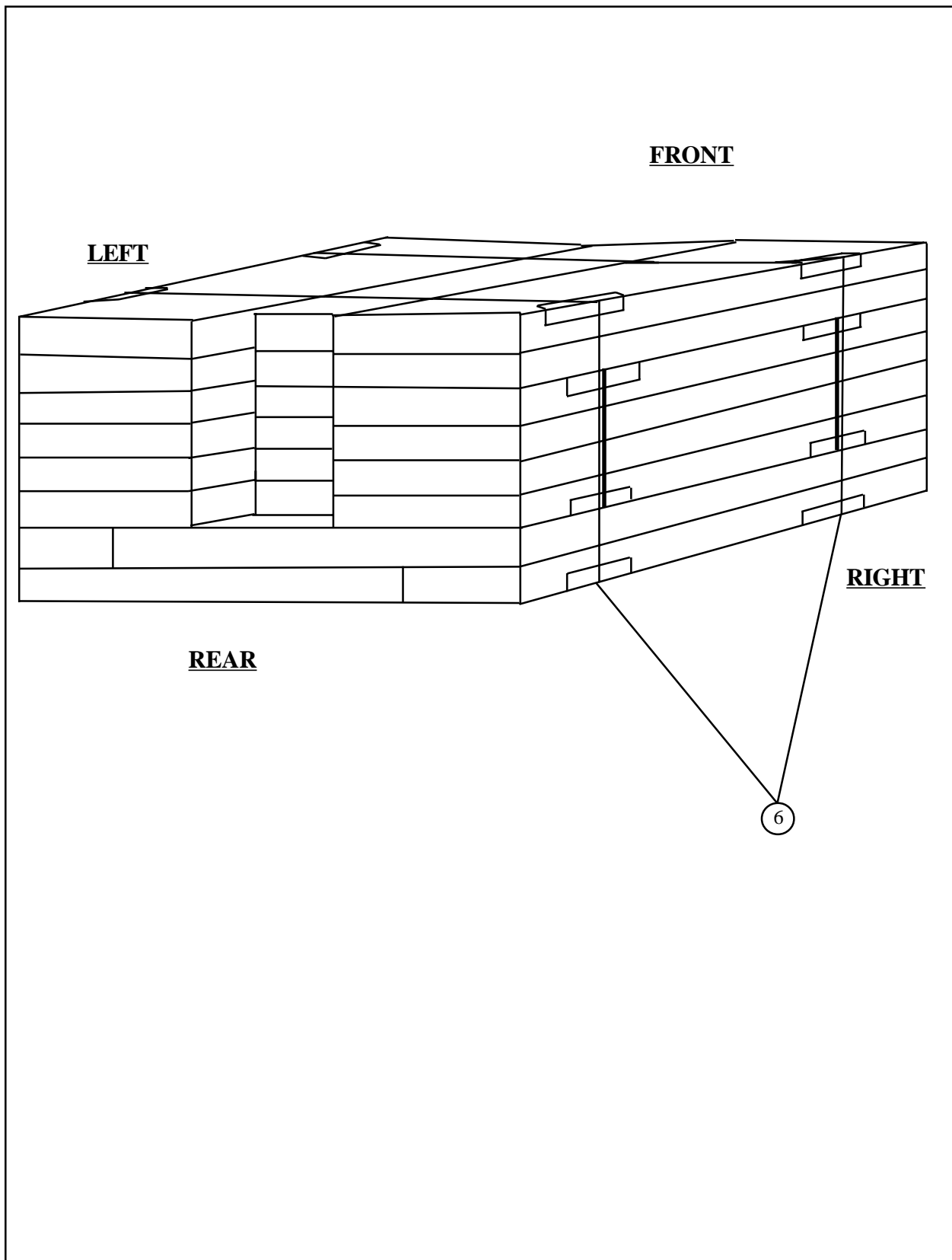

Figure 3-6. Stack 4 prepared (Continued)



- ① Position a 36- by 46-inch piece of honeycomb beside a 12- by 46-inch piece of honeycomb. Glue a 36- by 46-inch piece of honeycomb and a 12- by 46-inch piece of honeycomb on top of the first layer. Alternate them to form the base.
- ② Place a length of cloth backed tape on the bottom outer edges of the base. Position two 13-foot lengths of type III nylon cord under the base. Align with the strips of tape.
- ③ Form two stacks by gluing four pieces of 18- by 46-inch honeycomb together. Place a sufficient length of cloth backed tape on all edges. Run a length of 1/2-inch tubular nylon over the strips of tape and around the 18- by 46-inch stacks. Secure and tie with a square knot on the outside of the stack. Place the stack flush with the base. **(Do not glue to base.) (The 1/2-inch tubular nylon ties, PULL-OUT AIDS, are to assist in pulling the stacks out from under the vehicle during derigging.)**
- ④ Form two stacks by gluing two pieces of 18- by 46-inch honeycomb together. Place a length of cloth backed tape on each end. Position each stack on top of the existing stacks. **(Do not glue.)**
- ⑤ Form a stack by gluing six 12- by 36-inch pieces of honeycomb together. Position the stack between the two stacks in step 4, flush with the rear edge of the base. **(Do not glue to base.)**

Figure 3-7. Stack 5 prepared



⑥ Secure and tie the type III nylon cord around the completed honeycomb stack.

Figure 3-7. Stack 5 prepared (Continued)

Note: Place the plywood on the honeycomb stack after positioning stack on the platform.

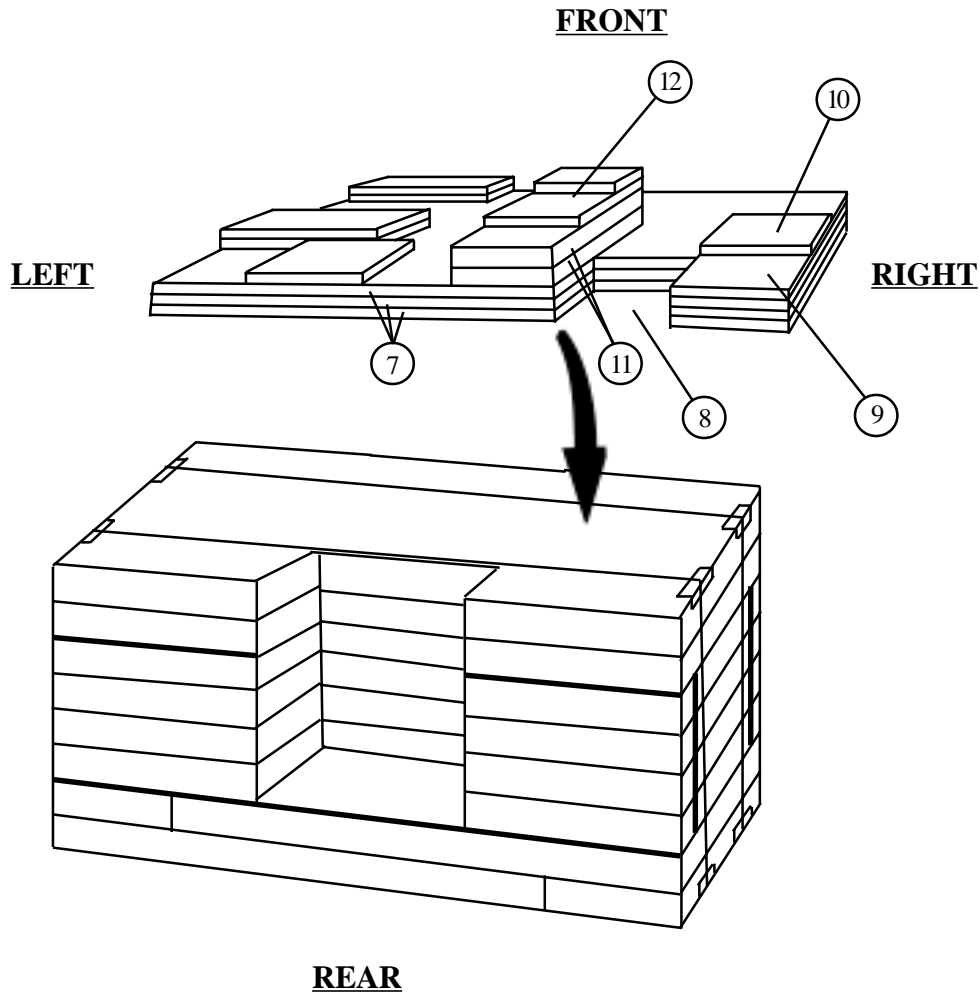

- ⑦ Glue and nail together three 48- by 46-inch pieces of 3/4-inch plywood.
- ⑧ Cut an 8-inch long and 12-inch deep cutout in the rear 48-inch edge of the plywood 8 inches from the right side.
- ⑨ Glue and nail one 8- by 16- by 3/4-inch piece of plywood on top of the plywood flush with the rear right edge.
- ⑩ Glue and nail one 8- by 6- by 3/4-inch piece of plywood on top of the plywood in step 9 flush with the front right edge.
- ⑪ Glue and nail two 2- by 8- by 26 1/2-inch pieces of lumber flush with the rear edge of the plywood and even with the left side of the cutout.
- ⑫ Glue and nail one 7 1/2- by 26 1/2-inch piece of 3/4-inch plywood on top of the lumber in step 11 flush with the front edge of the lumber.

Figure 3-7. Stack 5 prepared (Continued)

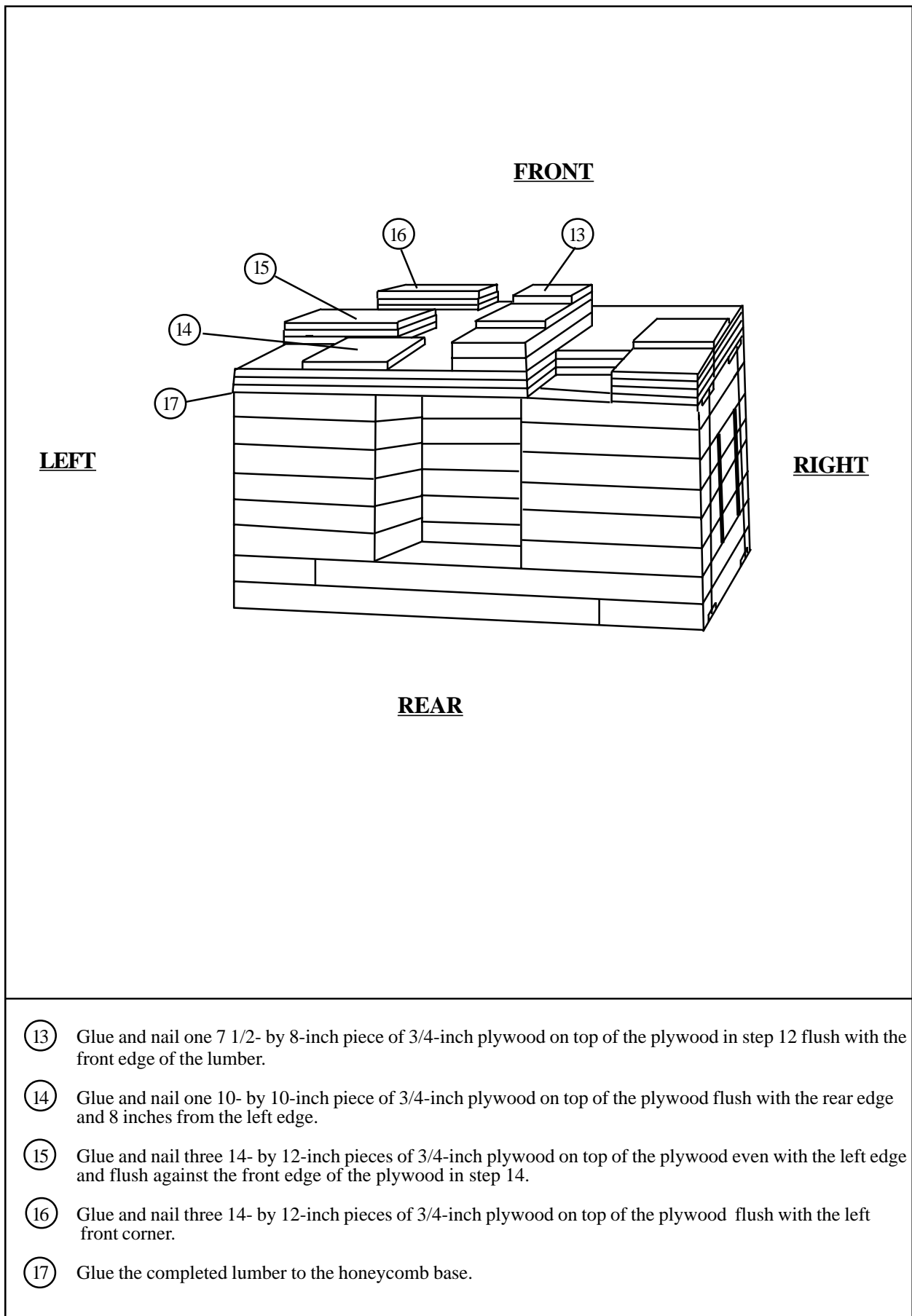
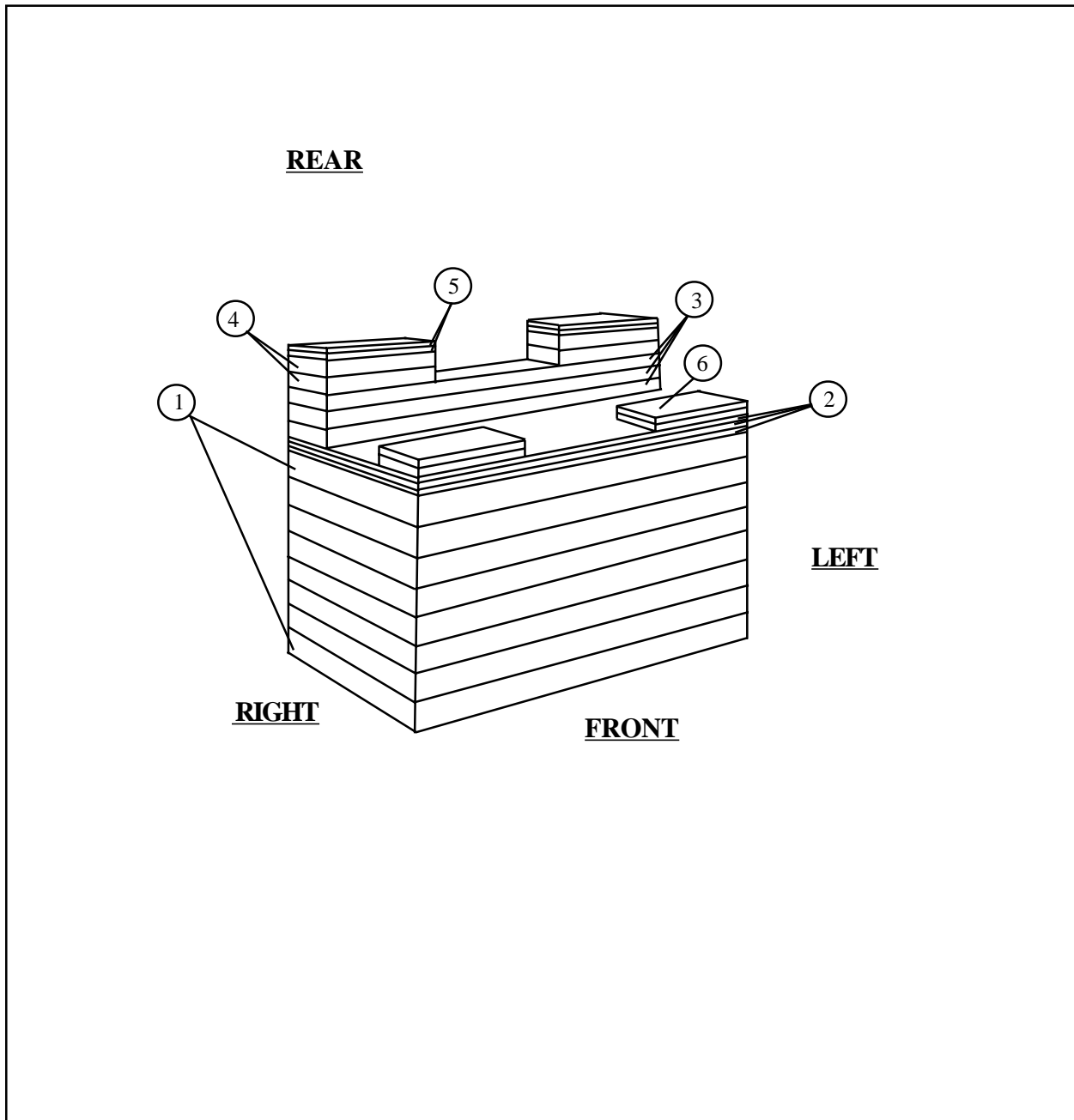
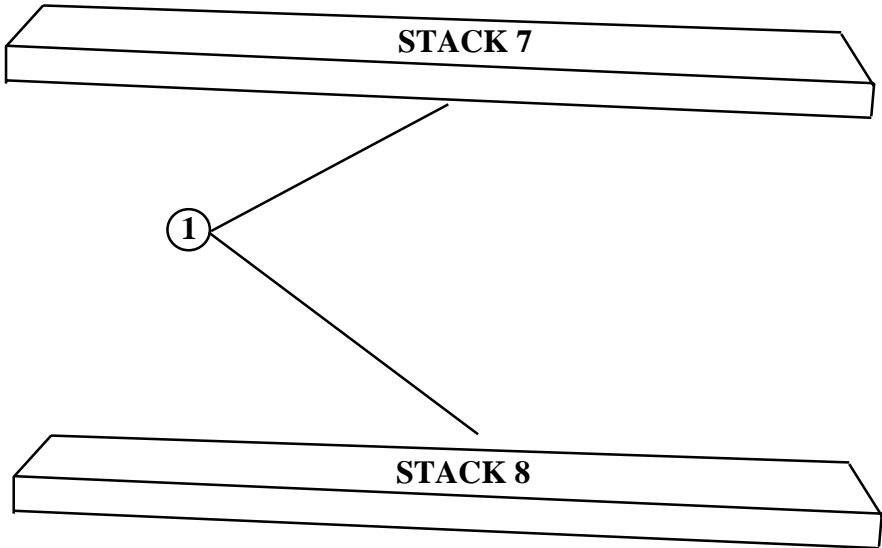

Figure 3-7. Stack 5 prepared (Continued)



- ① Glue eight 43- by 24-inch pieces of honeycomb together to form a base.
- ② Glue and nail three 43- by 24-inch pieces of 3/4-inch plywood together.
- ③ Glue and nail three 2- by 8- by 43-inch pieces of lumber. Center, glue and nail each piece of lumber flush with the rear edge of the plywood.
- ④ Glue and nail two 2 piece stacks of 2- by 8- by 12-inch lumber. Glue and nail one stack flush with the right edge and one stack flush with left edge of the lumber in step 3.
- ⑤ Glue two 2 piece stacks of 7 1/2- by 12-inch pieces of 3/4-inch plywood. Glue and nail one stack on top of the right and left stacks of lumber in step 4.
- ⑥ Glue two 2 piece stacks of 14- by 7-inch pieces of 3/4-inch plywood. Glue and nail each stack flush with the right and left front corners.
- ⑦ Glue the completed lumber to the honeycomb base.

Figure 3-8. Stack 6 prepared



① Cut two 18- by 96-inch pieces of honeycomb.

Figure 3-9. Stacks 7 and 8 prepared

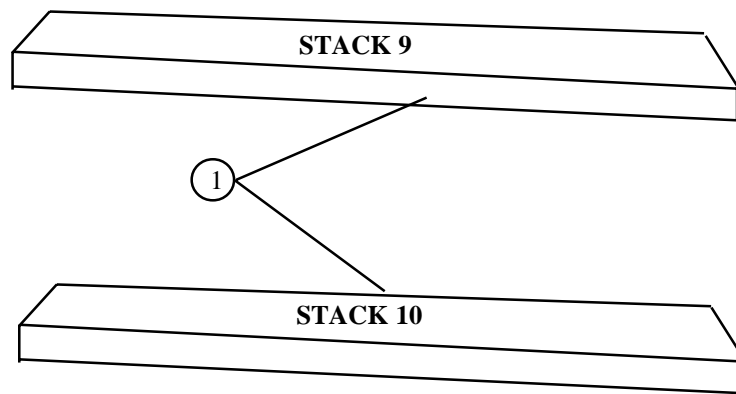

- ① Cut two 18- by 74-inch pieces of honeycomb.

Figure 3-10. Stacks 9 and 10 prepared

3-4. Positioning Honeycomb Stacks

Position the honeycomb stacks as shown in *Figure 3-11*.

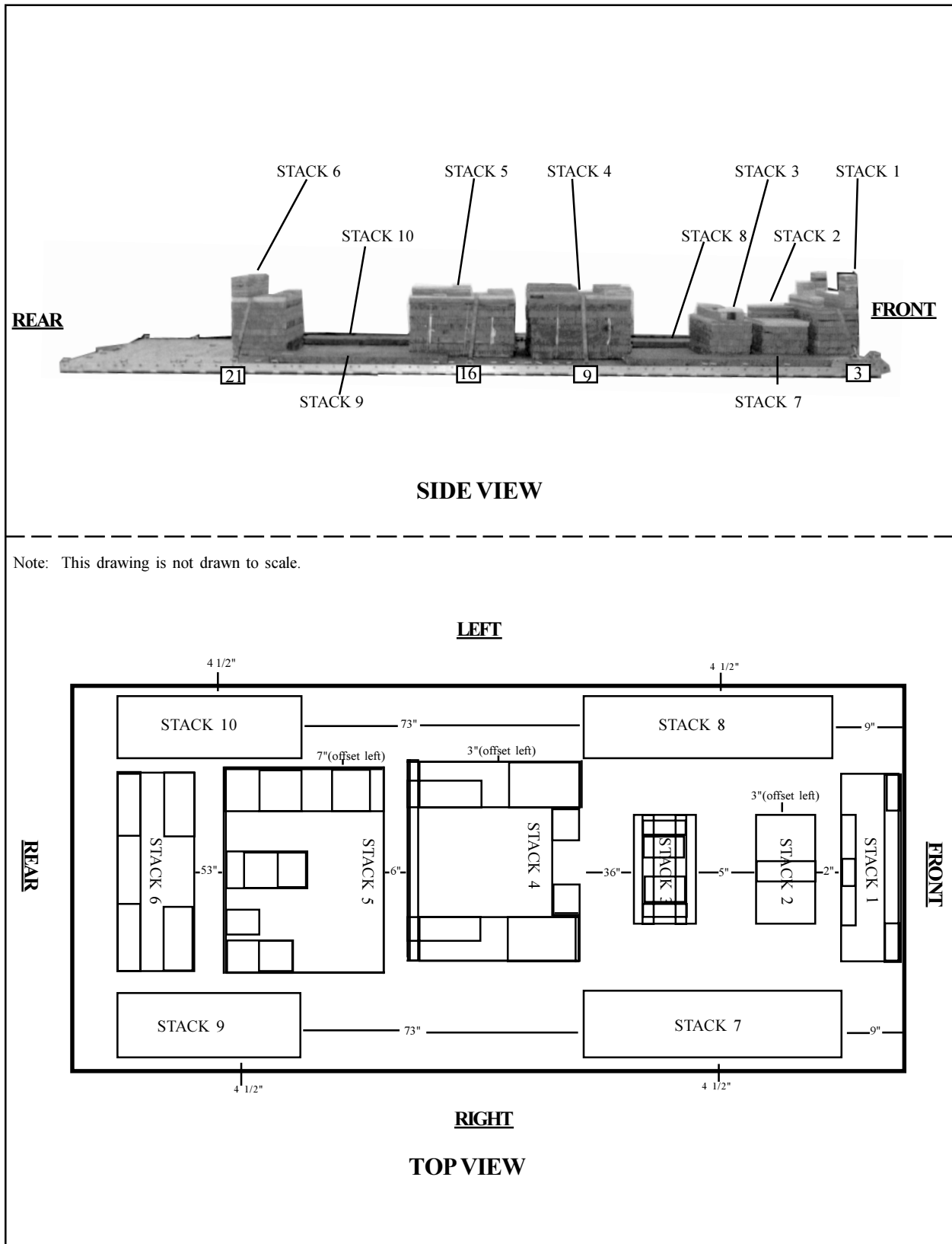

Note: This drawing is not drawn to scale.

Figure 3-11. Honeycomb stacks positioned on platform

Stack Number	Instructions
1	Position stack 1, centered and flush with the front of the platform. Secure the stack by passing a 15-foot tie-down lashing through clevis 3A and through its own D-ring. Route the lashing over the stack and secure it with a D-ring and loadbinder to clevis 3.
2	Position stack 2, offset 3 inches to the left of center and 2 inches from stack 1.
3	Position stack 3, centered and 5 inches from stack 2.
4	Position stack 4, offset 3 inches to the left of center and 36 inches from stack 3. Secure the stack by passing a 15-foot tie-down lashing through clevis 9A and through its own D-ring. Route the lashing over the stack and secure it with a D-ring and a loadbinder to clevis 9.
5	Position stack 5, offset 7 inches to the left of center and 6 inches from stack 4. Secure the stack by passing a lashing through clevis 16A and it's own D-ring. Route the lashing over the stack and secure it with a D-ring and a loadbinder to clevis 16.
6	Position stack 6, centered and 53 inches from stack 5. Secure the stack by passing a 15-foot tiedown lashing through clevis 21A and then through its own D-ring. Route the lashing over the stack and secure the end with a D-ring and loadbinder to clevis 21.
7	Position stack 7, 9 inches from the front edge of the platform and 4 1/2 inches from the right platform side rail.
8	Position stack 8, 9 inches from the front edge of the platform and 4 1/2 inches from the left platform side rail.
9	Position stack 9, 73 inches from stack 7 and 4 1/2 inches from the right platform side rail.
10	Position stack 10, 73 inches from stack 8 and 4 1/2 inches from the left platform side rail.

Figure 3-11. Honeycomb stacks positioned on platform (Continued)

3-5. Preparing Truck

Prepare the M1093 truck as shown in *Figure 3-12* and as described below.

- a. Make sure the fuel tank is not more than 3/4 full.
- b. Make sure the batteries and compartment comply with AFJMAN 24-204/TM 38-250.

The following is a list of materials used for truck preparation.

PIECES	WIDTH (inches)	LENGTH (inches)	MATERIAL
1	36	36	Honeycomb
1	36	80	Honeycomb
2	18	60	Honeycomb
10	2- by 6	13	Lumber
2	4- by 4	6	Lumber
2	4- by 4	15	Lumber
4	2- by 4	6	Lumber
1	10	10	3/4-inch Plywood
3	2- by 6	6	Lumber
1	36	96	Honeycomb
4	1/2	10	Bolts (washers and nuts)

- NOTES:**
1. The truck should arrive at the rigging site with the gun turret removed from roof and replaced with flat insert.
 2. The cargo/troop carrier cover, bows, cargo/troop carrier cover poles, bed stakes, seat bars, seats and side rails located in the rear of the truck should be removed and packed as basic load.

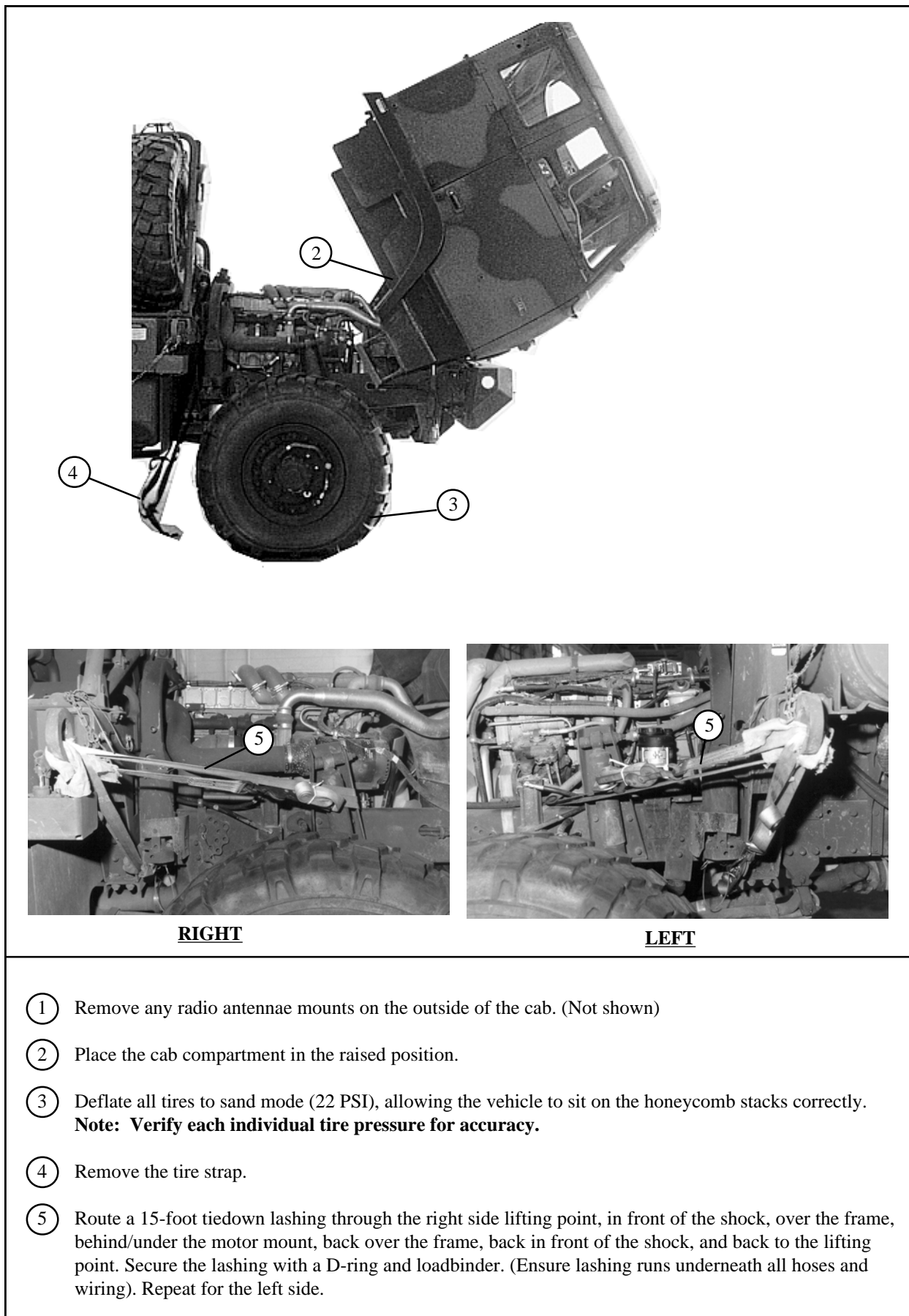
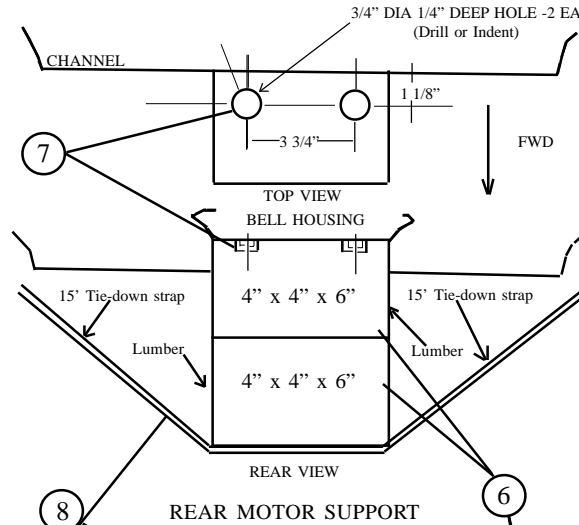

Figure 3-12. Truck prepared

Note: This drawing is not drawn to scale.



- ⑥ Cut two 4- by 4- by 6-inch pieces of lumber.
- ⑦ Countersink two holes 3/4-inch in diameter 1/4-inch deep and 1 1/8 inch from the edge on the 6 inch side, with a 3 3/4 inch center to center hole measurement in one piece of 4- by 4- by 6-inch lumber. Place the other 4 - by 4- by 6-inch piece of lumber under the first piece of lumber and tape them together leaving the holes exposed.
- ⑧ Place the countersunk holes of the 4- by 4- by 6-inch piece of lumber over the bolts in the bell housing. Route a 30-foot lashing through the right side lifting point under the 4- by 4- by 6-inch piece of lumber and through the left side lifting point, and back under the 4- by 4- by 6-inch piece of lumber. Secure with a D-ring and loadbinder.

Figure 3-12 Truck prepared (Continued)

Note: This drawing is not drawn to scale.

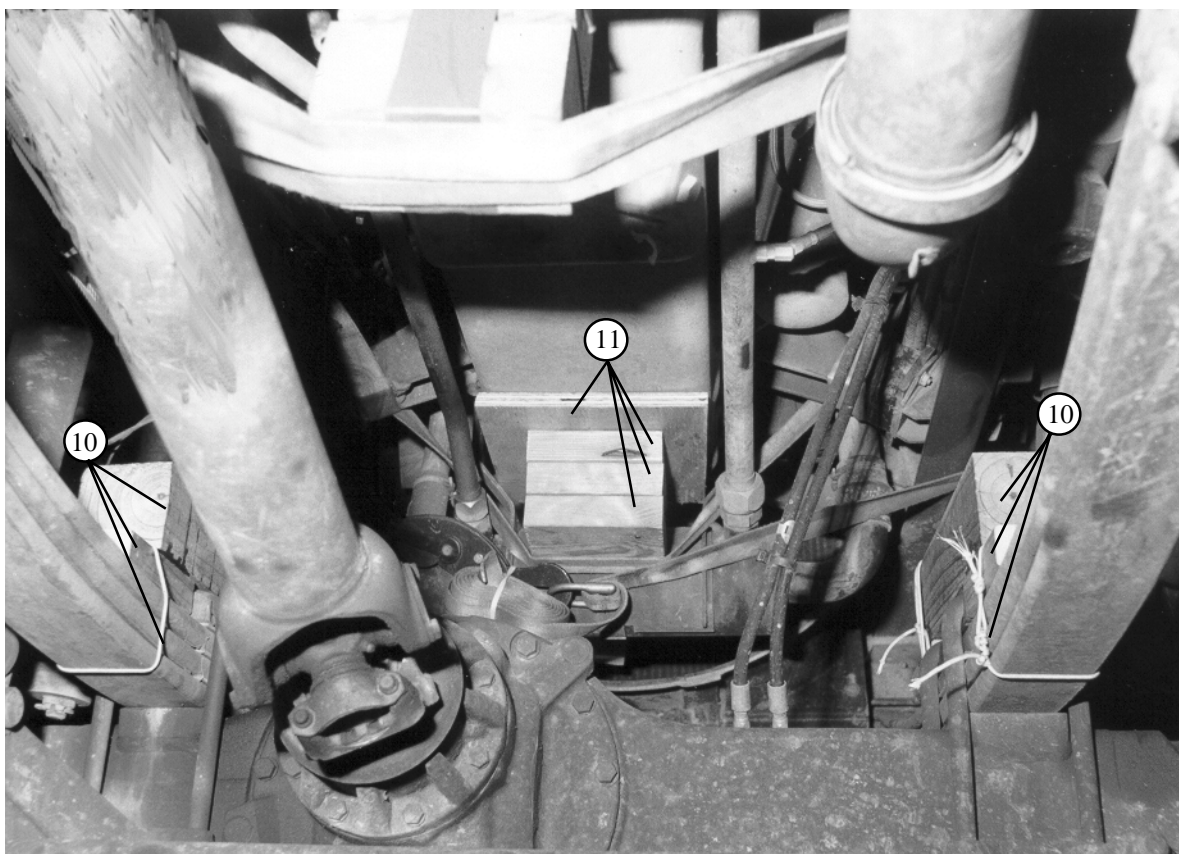
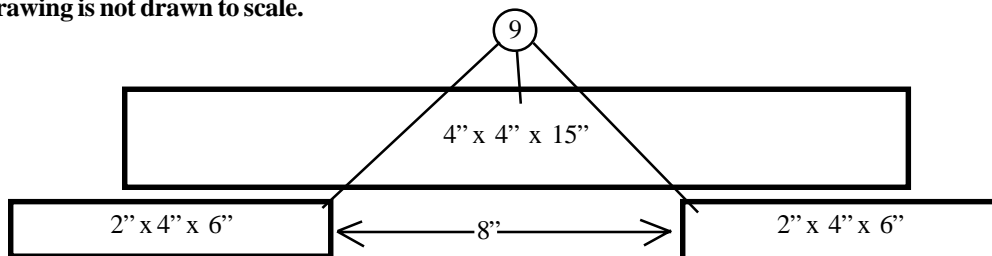

- ⑨ Glue and nail together one 4- by 4- by 15-inch piece of lumber and two 2- by 4- by 6-inch pieces of lumber for each axle.
- ⑩ Position them on top of the right and left axles and secure with type III nylon cord.
- ⑪ Position a 10- by 10- by 3/4-inch piece of plywood and three 2- by 6- by 6-inch pieces of lumber against the oil pan and front of the engine.

Figure 3-12. Truck prepared (Continued)



- ⑫ Route a 15-foot lashing in rear of motor mounts around the left and right main frames (under all hoses). Secure the lumber and plywood with D-ring and load binder.

Figure 3-12. Truck prepared (Continued)

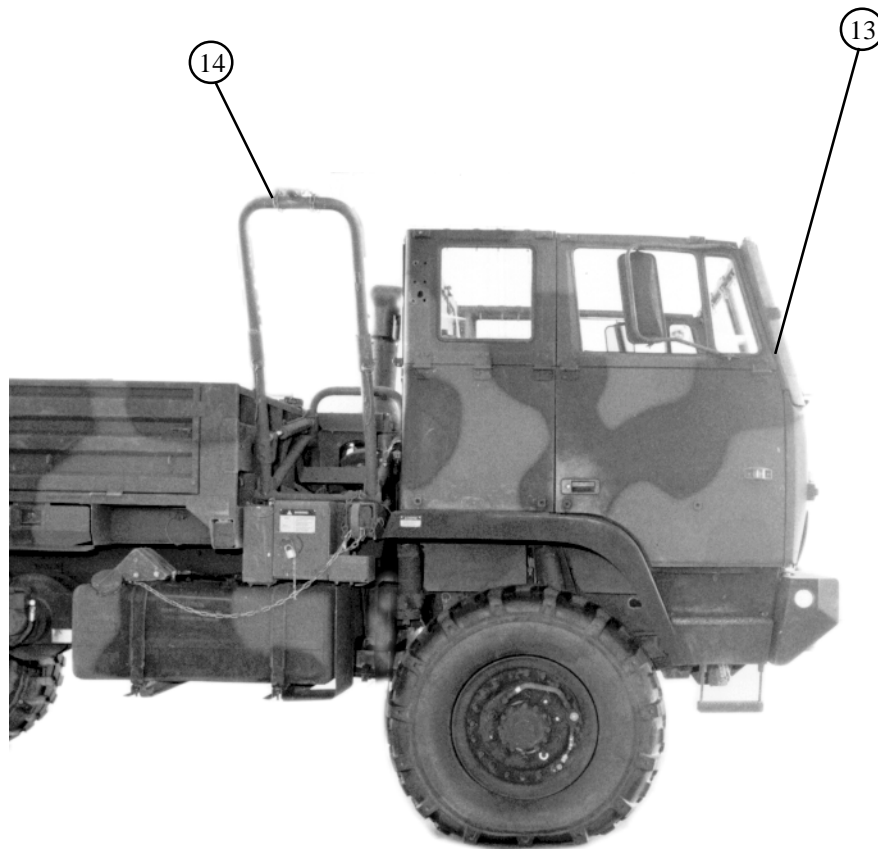

- ⑬ Place the cab in the lowered position.
- ⑭ Remove the spare tire from the rack and leave the spare tire carrier down.
- ⑮ Remove the davit. (It is attached to the back of cab.) (Not shown)
- ⑯ Remove the windshield wipers and stow the bolts and blades in the cab. (Not shown)

Figure 3-12. Truck prepared (Continued)

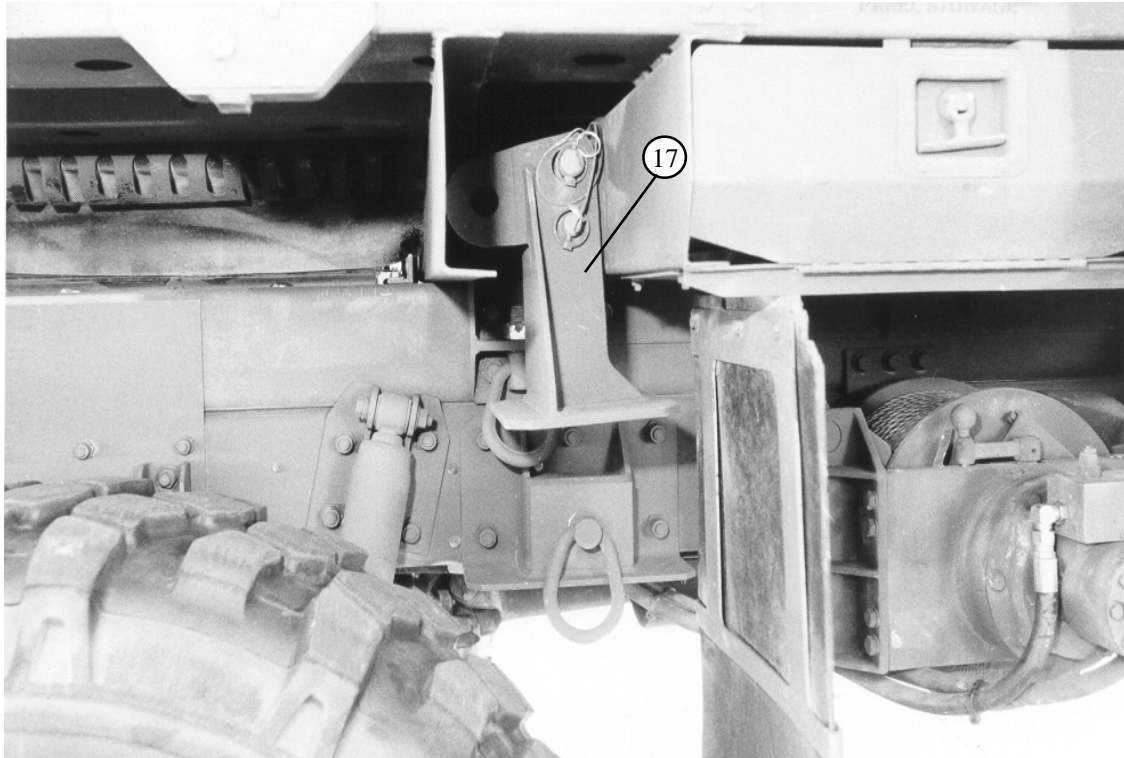

- ①7 Remove the front support brackets from under the bed of the truck.
- ①8 Install them on the front of the vehicle and wrap the outside edges with cellulose wadding and tape.

Figure 3-12. Truck prepared (Continued)

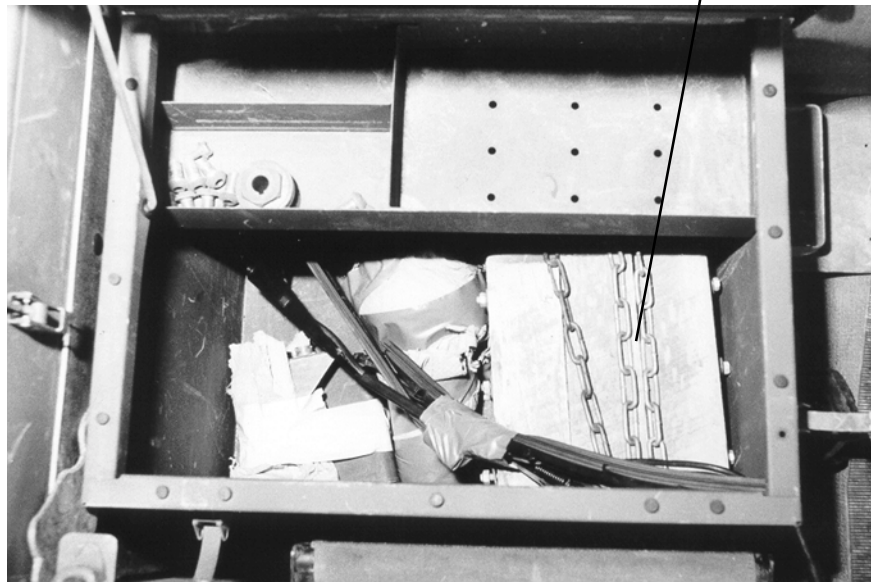
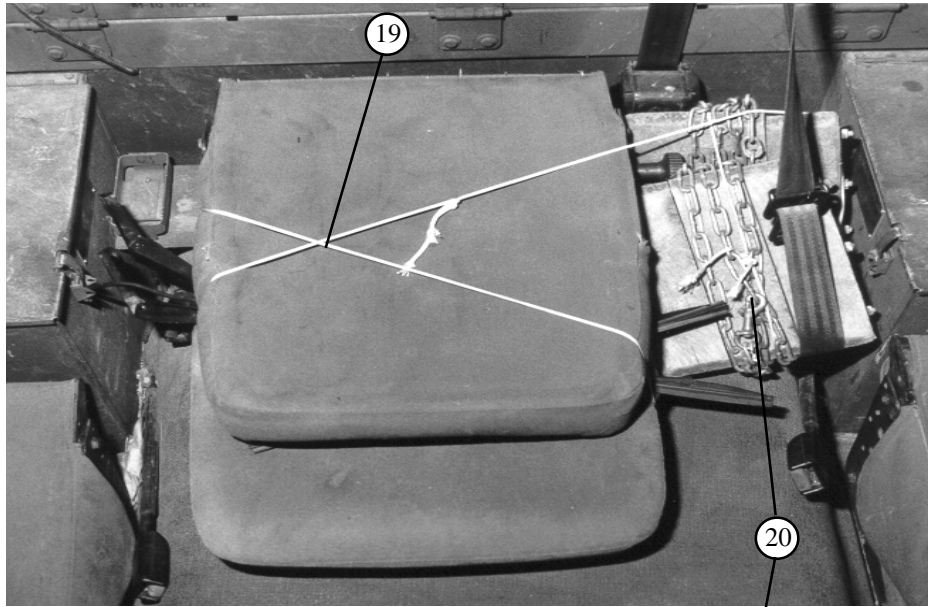

- ①⑨ Secure the chock blocks in cab or in storage box.
- ②⑩ Lower the seats and secure with type III nylon cord.
- ②⑪ Secure the fire extinguisher with type III nylon cord. (Not shown)

Figure 3-12. Truck prepared (Continued)

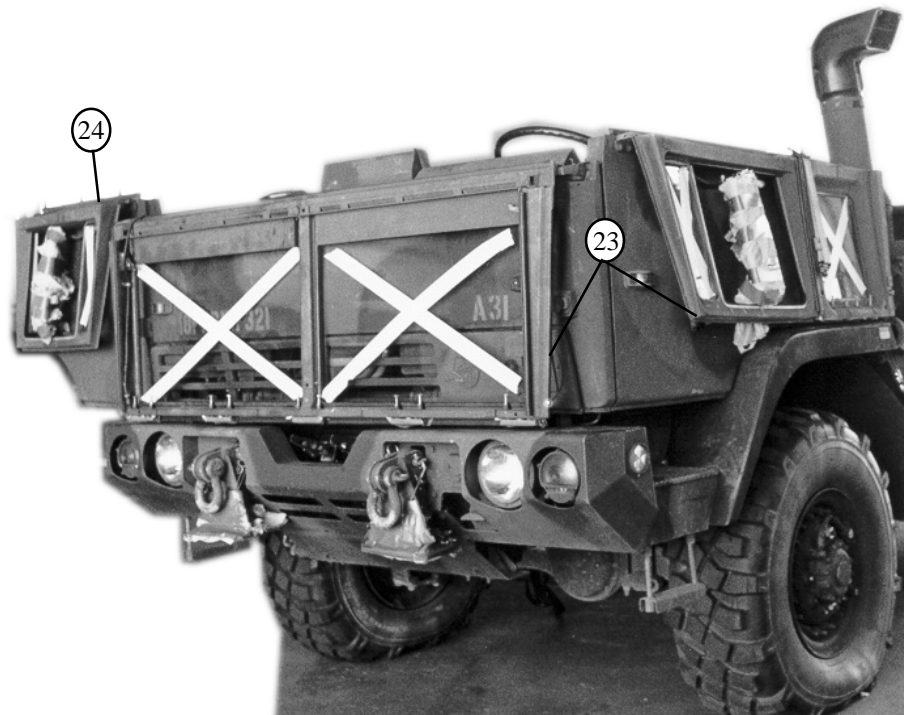
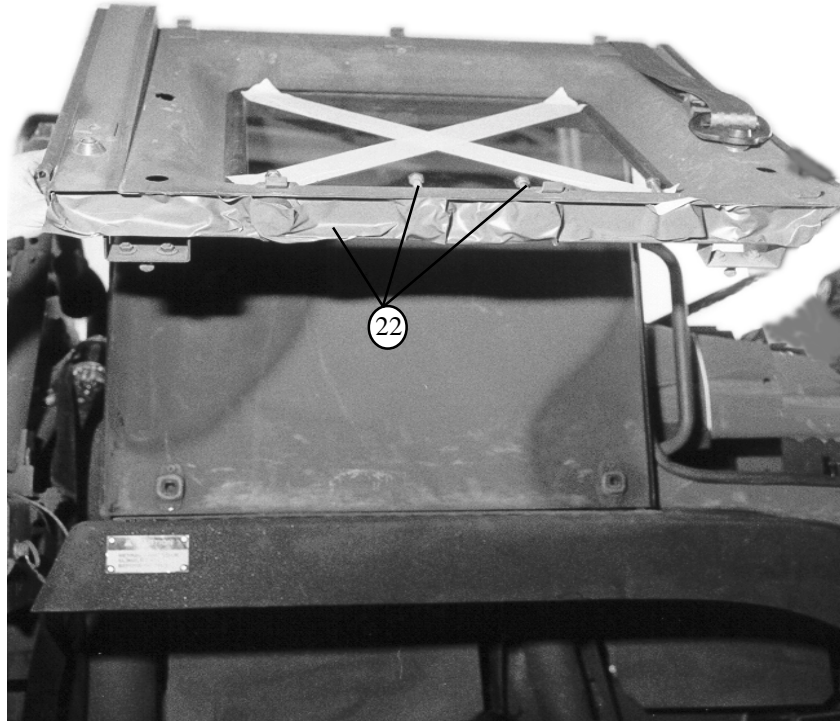

- ②② Remove the roof and secure the roof bolts with tape.
- ②③ Fold down the windows, windshield and rear of the cab.
- ②④ Roll the windows down.

Figure 3-12. Truck prepared (Continued)

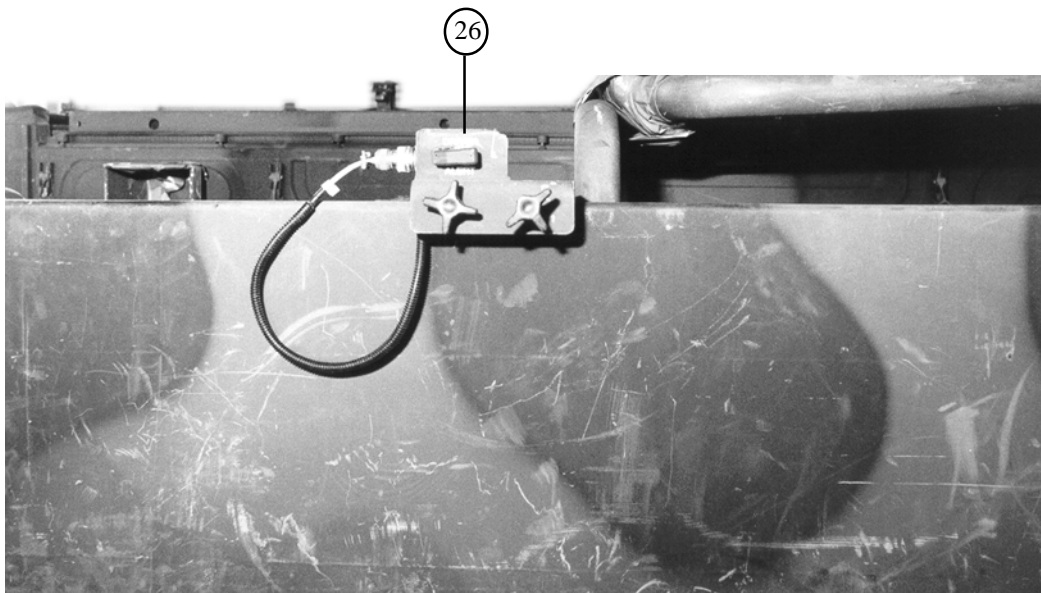

- ②5 Remove the air intake stack. Wrap it with cellulose wadding and stow in the cab.
- ②6 Remove the driver alert switch and stow in the cab. Tape the electrical connection.
- ②7 Remove the sunvisors and stow in the cab. (Not shown)

Figure 3-12. Truck prepared (Continued)

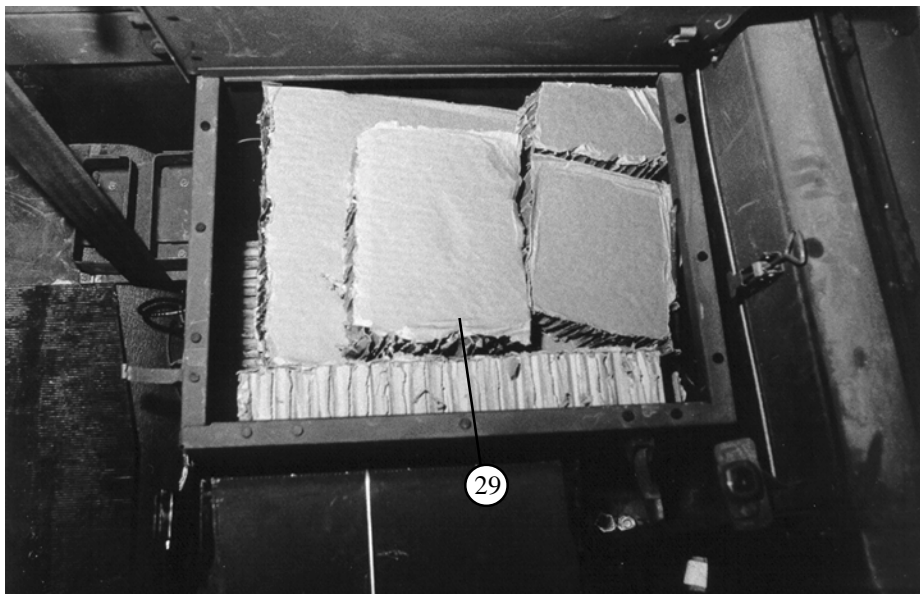
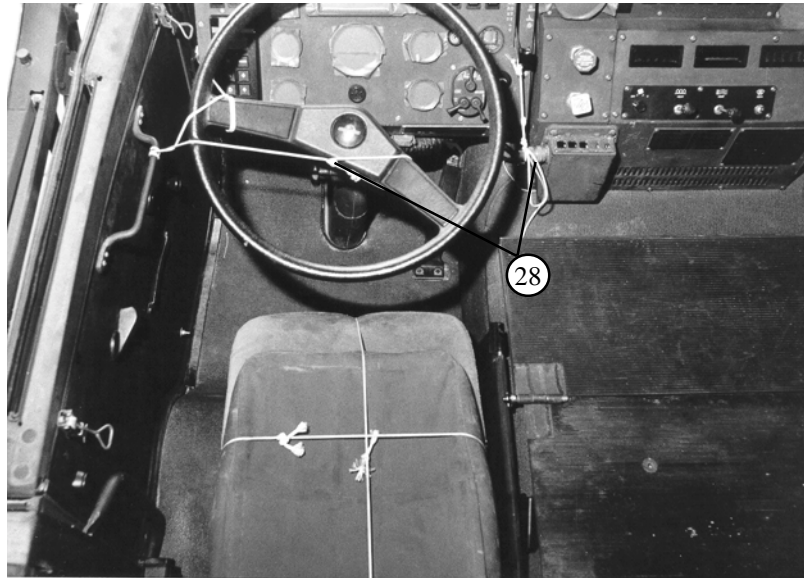

- ②⑧ Secure the steering wheel and hand throttle with type III nylon cord.
- ②⑨ Fill the driver and passenger storage boxes with honeycomb.

Figure 3-12. Truck prepared (Continued)

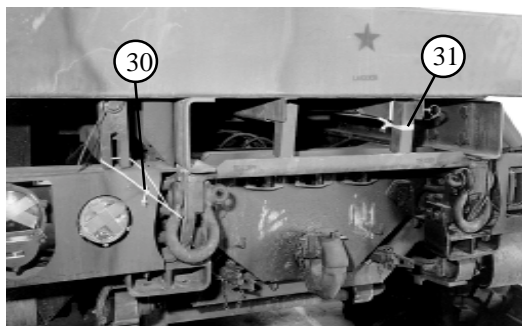
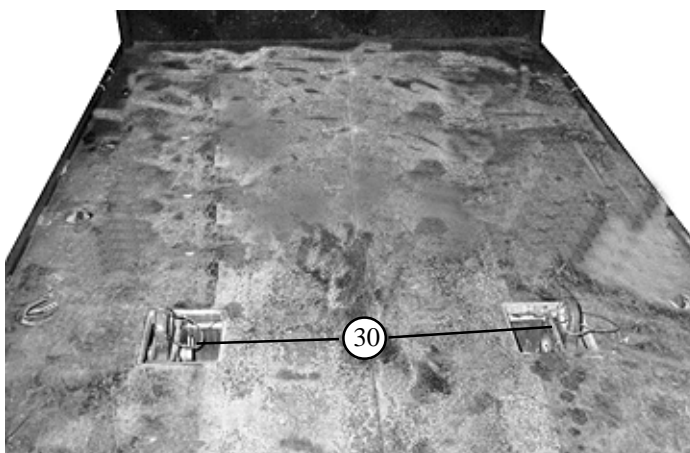

- ③① Safety the left and right rear lifting pins (located on the truck bed near the rear with cover over them) with type III nylon cord. Route the type III nylon cord through the safety pin pull ring and around the safety pin. Stow the covers in the cab.
- ③② Secure the ladder in place with a length of 1/2 -inch tubular nylon webbing.
- ③③ Secure the tow bar on the left side of the truck with a piece of type III nylon cord to the top left rear tie-down point.

Figure 3-12. Truck prepared (Continued)

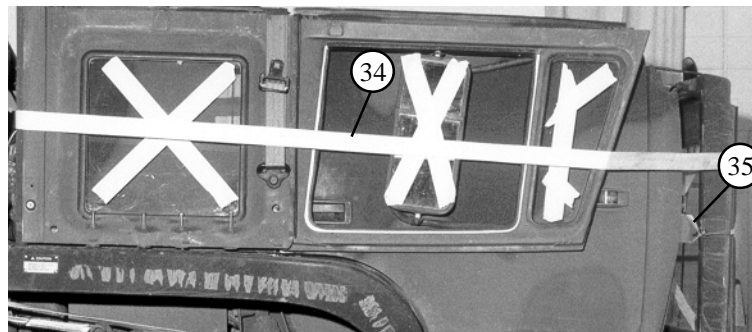
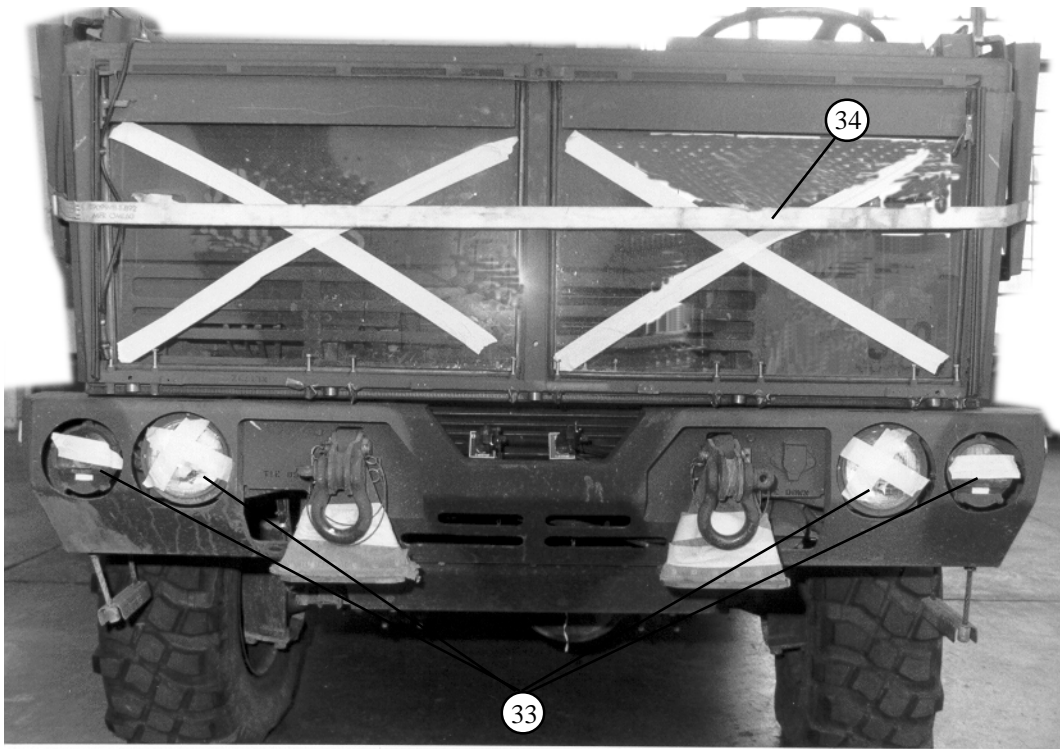

- ③③ Tape all lights, reflectors, and windows and pad mirrors with cellulose wadding and tape.
- ③④ Route a 30-foot lashing around the cab and secure with a loadbinder and D-rings in the rear of the cab. (Ensure D-rings do not come in contact with the glass).
- ③⑤ Secure the windshield to the left and right windshield stops with 1/2 -inch tubular nylon webbing.

Figure 3-12. Truck prepared (Continued)

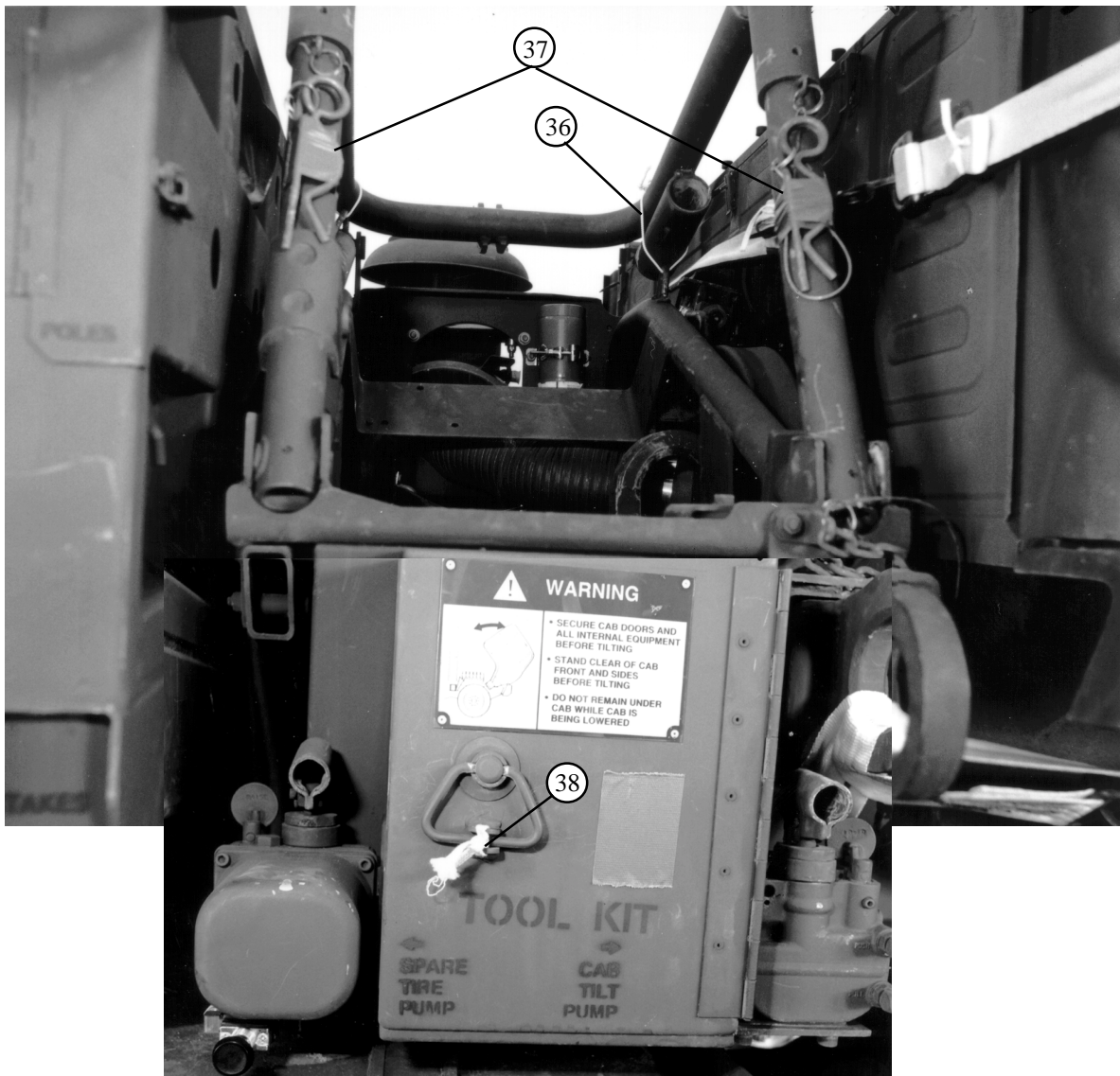

- ③⑥ Retract the spare tire carrier and secure with 1/2-inch tubular nylon webbing.
- ③⑦ Tape the chains and pins in place on the spare tire carrier.
- ③⑧ Secure the tool kit access panel with a length of type III nylon cord.

Figure 3-12. Truck prepared (Continued)

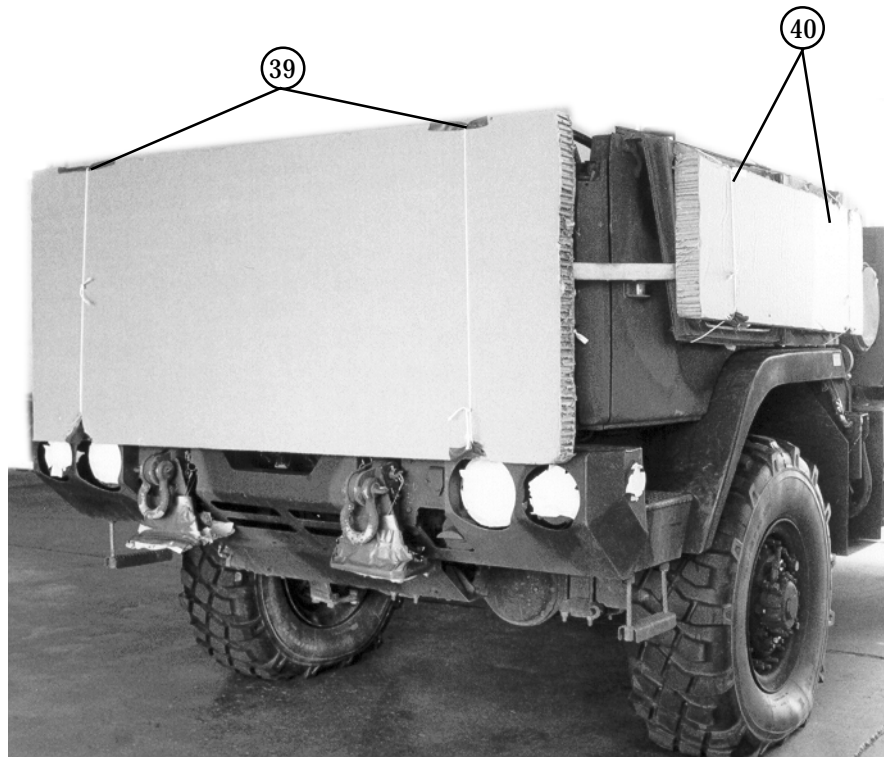

- ③⑨ Place a 36- by 80-inch piece of honeycomb on the windshield. Secure it with two lengths of type III nylon cord.
- ④⑩ Place one 18- by 60-inch piece of honeycomb on the left side window and one piece on the right side window. Secure each with two lengths of type III nylon cord.

Figure 3-12. Truck prepared (Continued)

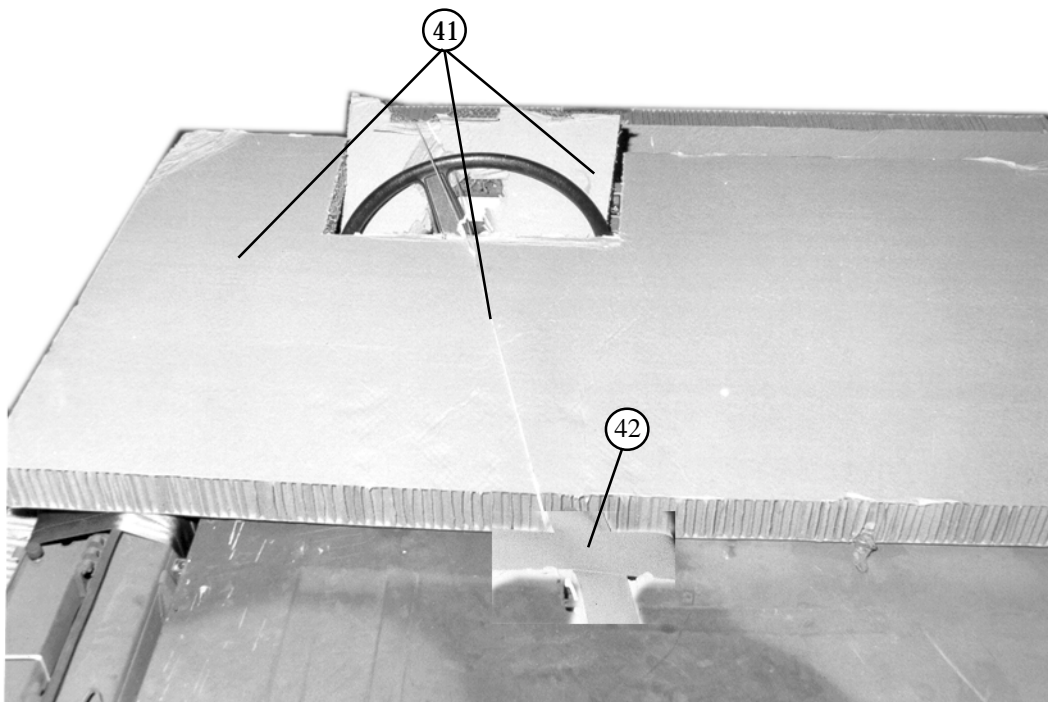

- ④1 Place a 36- by 96-inch piece of honeycomb over the driver's compartment. Cut out a section (approximately 12- by 21-inches) for the steering wheel and place it over the instrumentation panel in the cab. Secure both pieces with type III nylon cord.
- ④2 Pad the davit holders with cellulose wadding and secure with cloth-backed tape.

Figure 3-12. Truck prepared (Continued)

Note: Hoses that will interfere with the attaching of the suspension slings should be tied back.

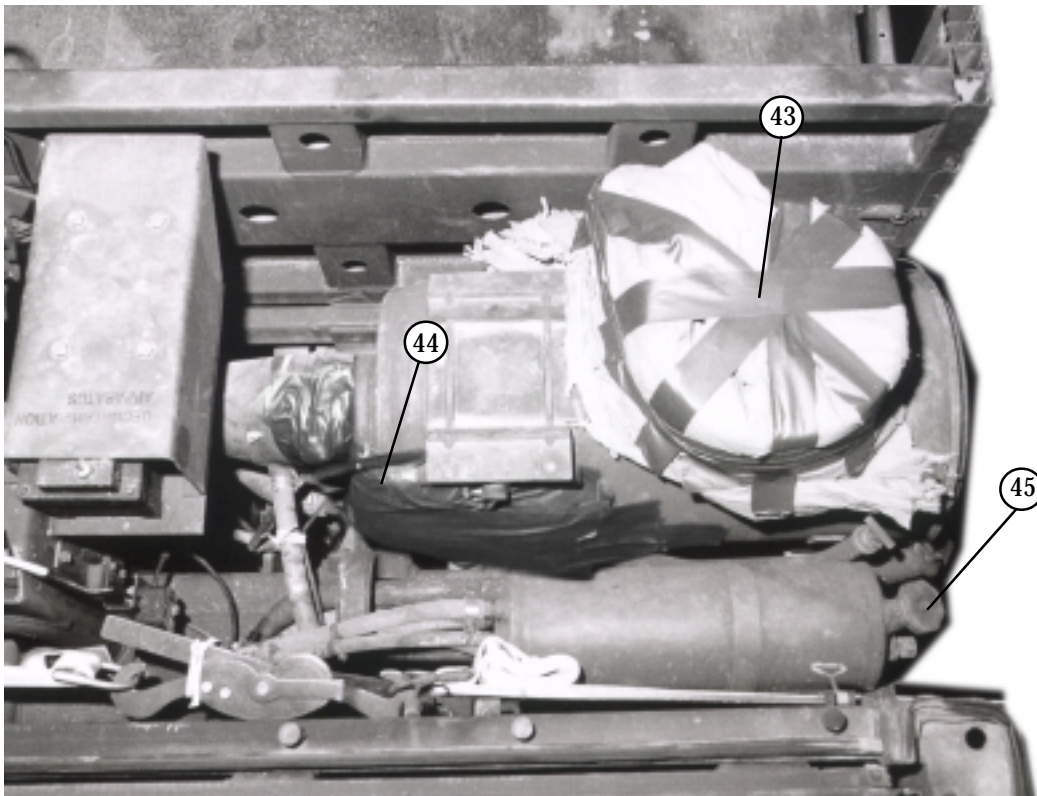

- ④3 Wrap the air intake fitting with cellulose wadding and secure with cloth-backed tape. Secure the end hose out of the way with type III nylon cord.
- ④4 Pad the lower air intake fitting with felt and secure with cloth-backed tape.
- ④5 Ensure the radiator pressure cap is secure.

Figure 3-12. Truck prepared (Continued)

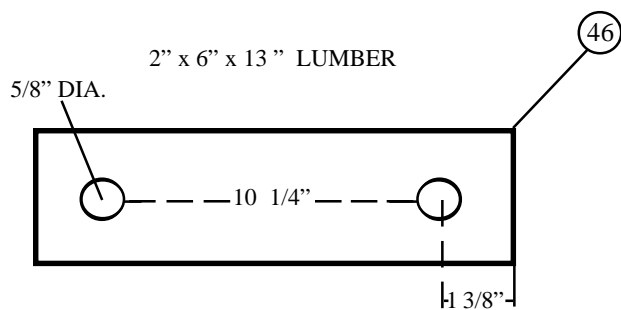

- (46) Cut ten 2-by 6-by 13-inch pieces of lumber. Drill two 5/8-inch diameter holes 1 3/8-inches from the edge, with a 10 1/4-inch center to center hole measurement in each piece of lumber.
- (47) Bolt five 2-by 6-by 13-inch pieces of lumber to the left and right side frame pads using two 1/2-by 10-inch bolts on each side.

Figure 3-12. Truck prepared (Continued)

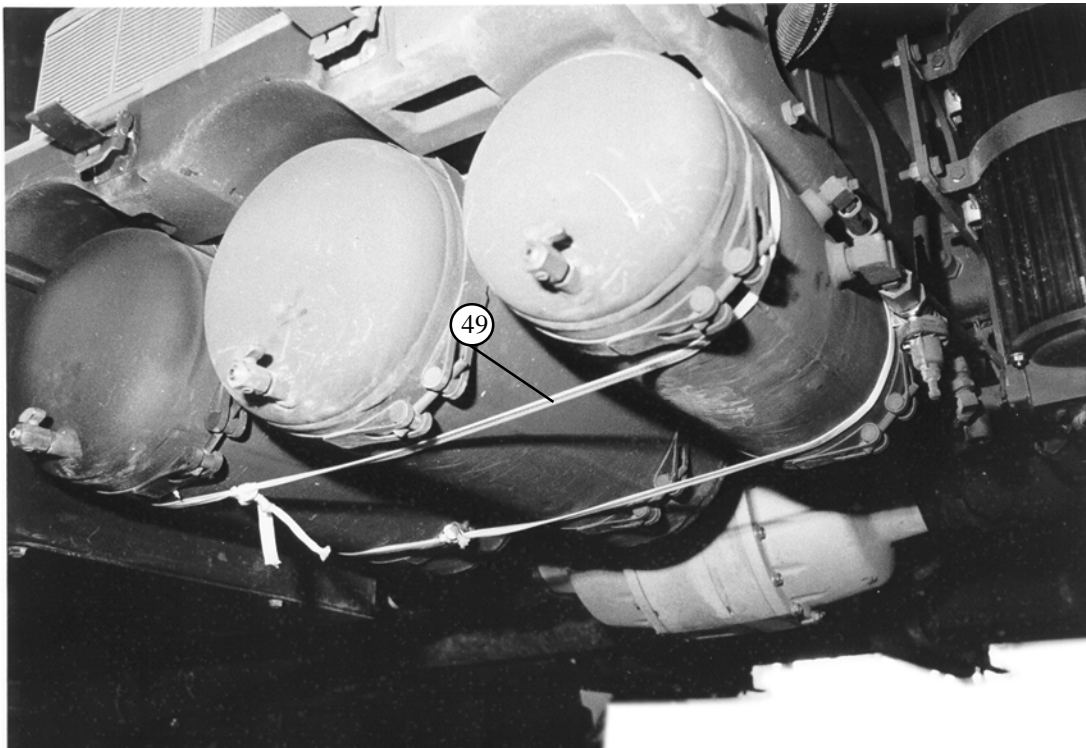
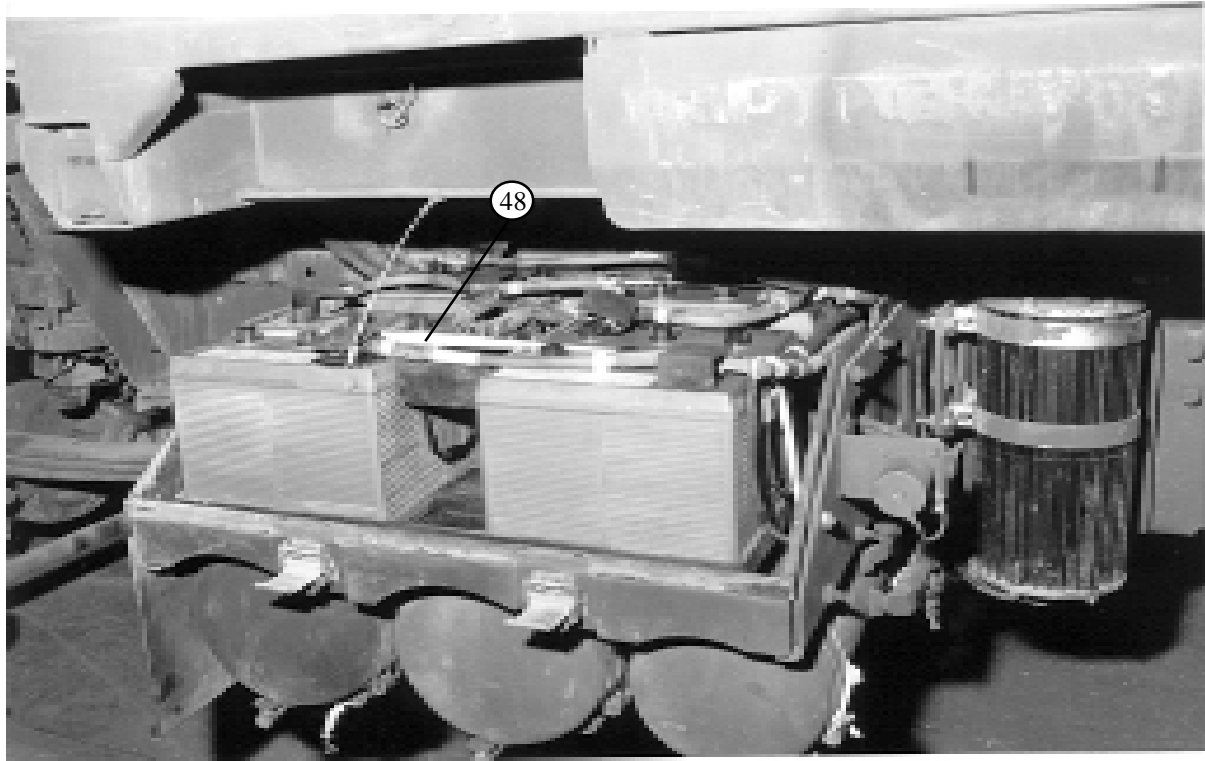

- ④8 Remove the battery box cover and secure the batteries in place with two lengths of 1/2-inch tubular nylon webbing.
- ④9 Run the nylon webbing over the batteries down through the battery box and under the air tanks.

Figure 3-12. Truck prepared (Continued)

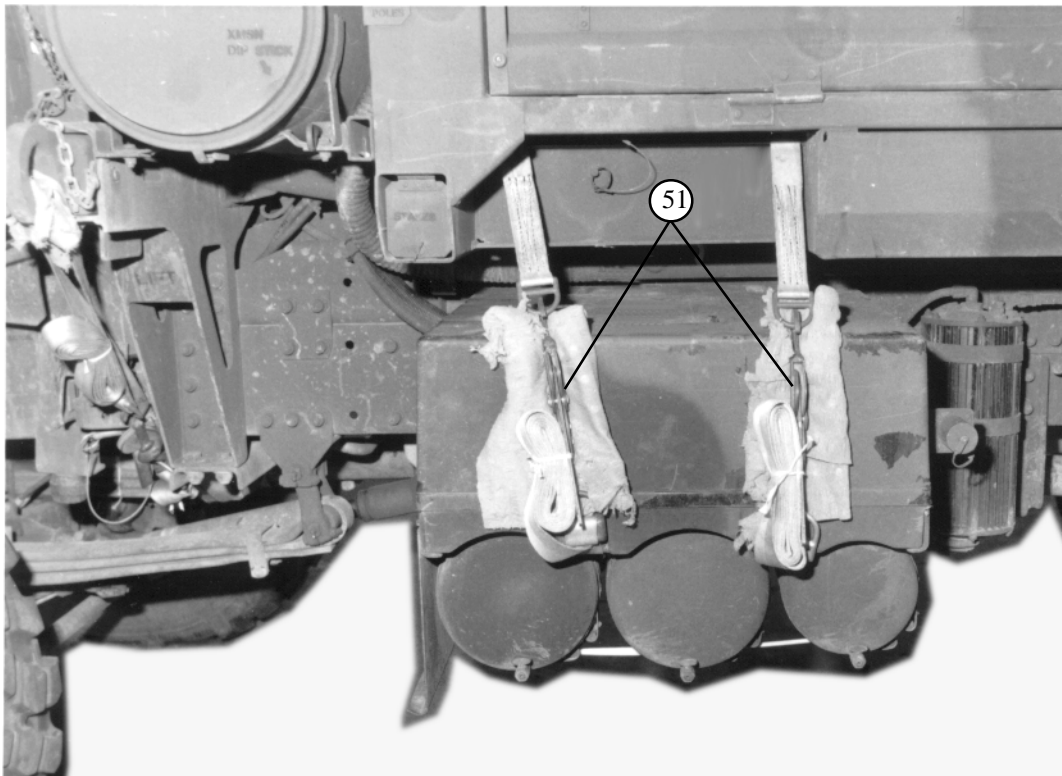
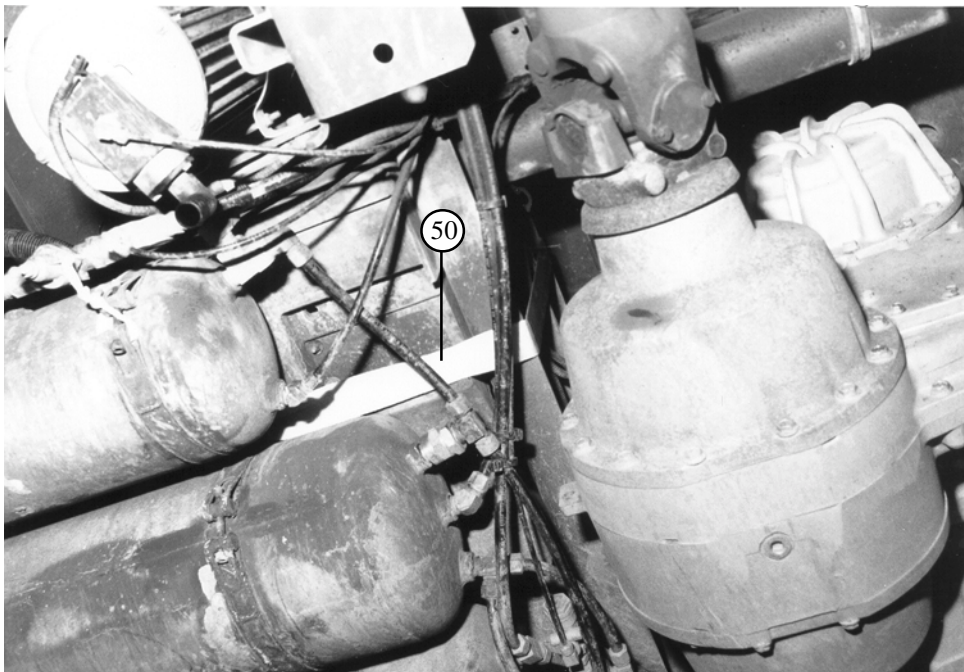

- ⑤⑩ Replace the cover. Route two 15-foot lashings around the main frame, under the battery box, between the air tanks. Ensure hoses are not crimped.
- ⑤① Secure with D-ring and loadbinder on top of battery box. Pad with felt or cellulose wadding.

Figure 3-12. Truck prepared (Continued)

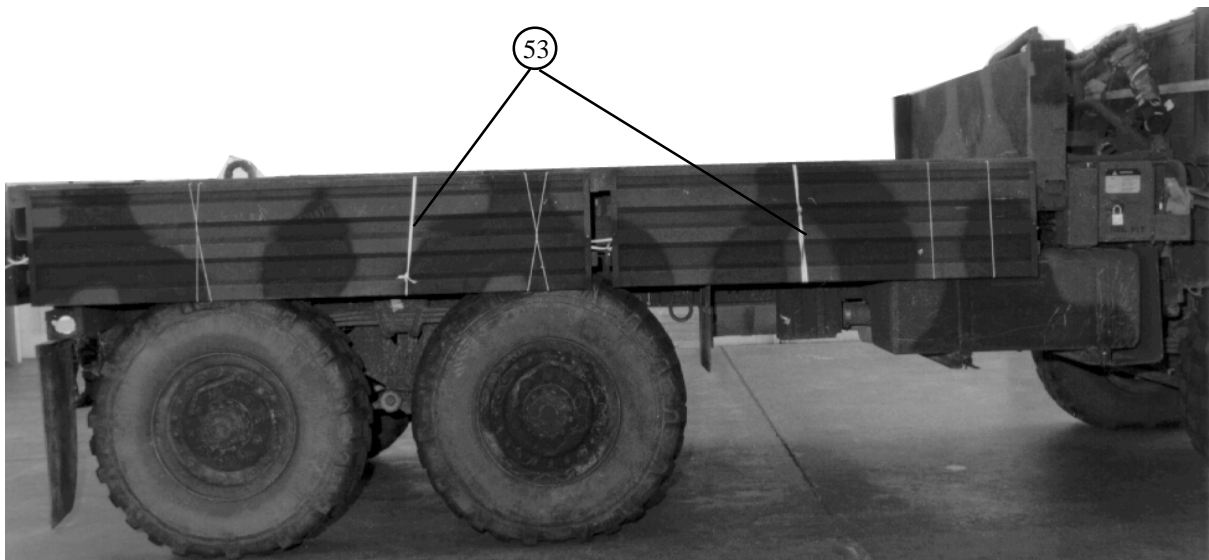
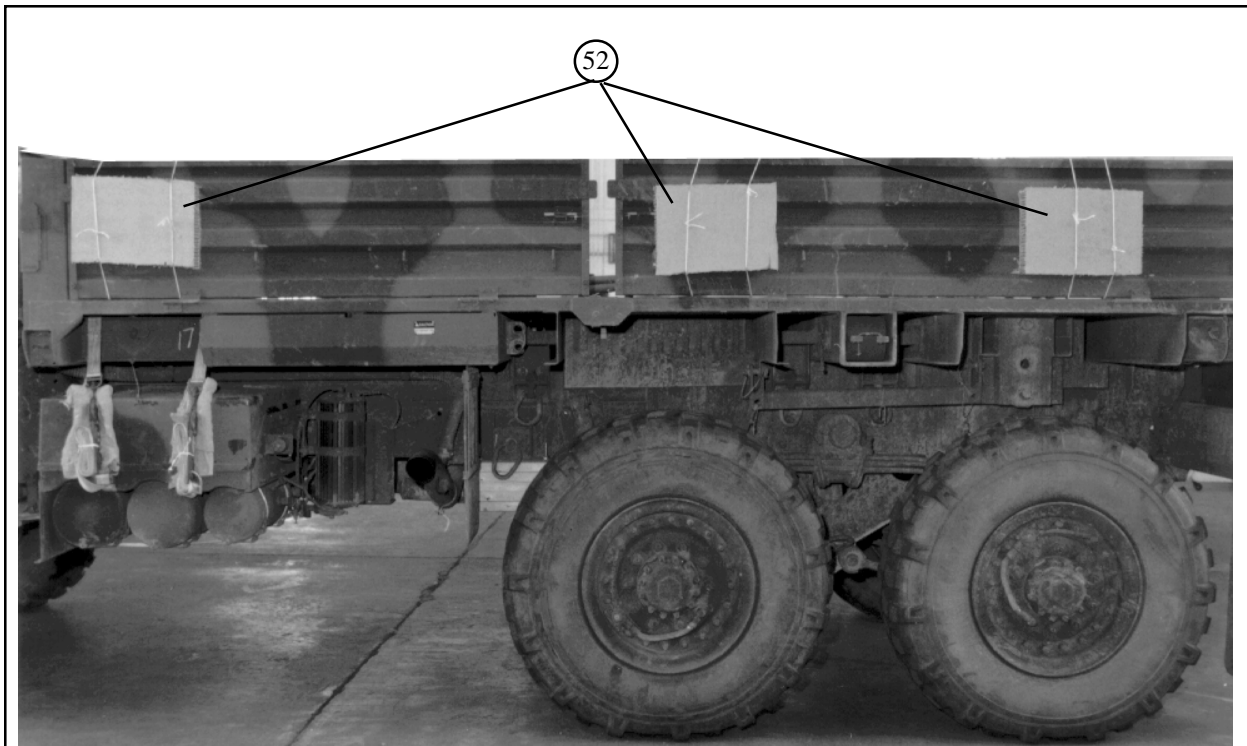

- ⑤2 Raise the side panels and place an 11- by 16-inch piece of honeycomb on each contact point. Position the pieces on the front panels where they will come in contact with the fuel tank and battery box. Place the honeycomb on the rear panels where they will come in contact with both sets of tires. Secure the honeycomb in place with type III nylon cord.
- ⑤3 Secure the side panels and tailgate down using 1/2-inch tubular nylon webbing and tie to convenient locations on the truck.

Note: Steps 52 and 53 must be secured very well. No slippage of the ties is allowed. If the ties are not secure, damage to the side panels will occur.

Figure 3-12. Truck Prepared (Continued)

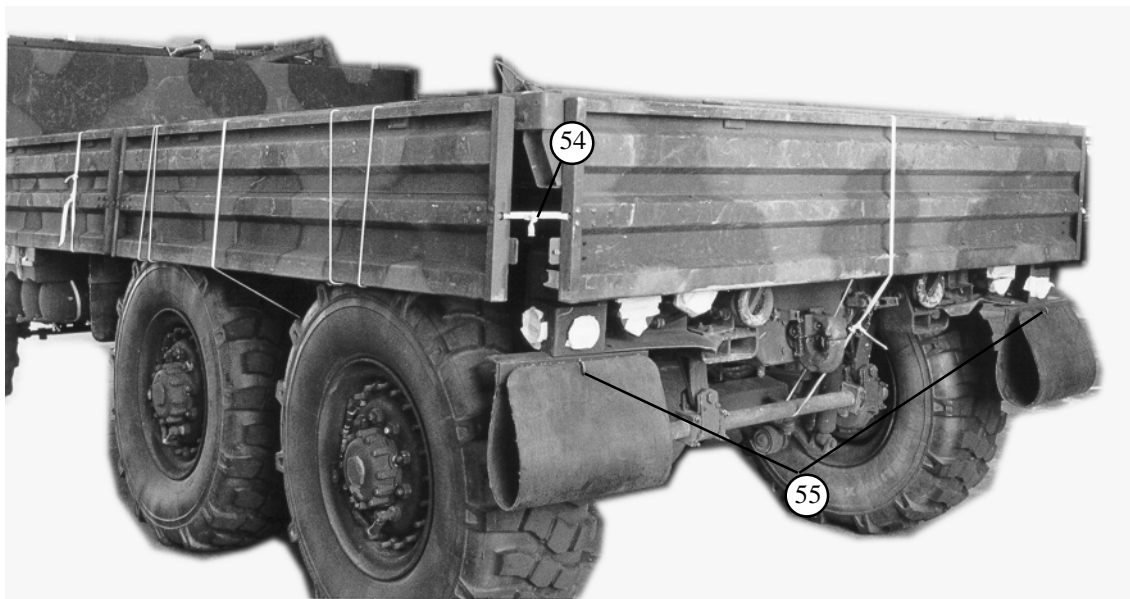

- ⑤④ Using 1/2-inch tubular nylon webbing, tie the corners of the rear side panels and tailgate together. Tie the front of the forward side to convenient locations on the truck.
- ⑤⑤ Tie the mud flaps up with type III nylon cord.

Figure 3-12. Truck Prepared (Continued)

3-6. Stowing Basic Load

Basic accompanying load consists of the roof, spare tire, tire strap, davit, cargo/troop carrier cover, bows, cargo/troop carrier cover poles, bed stakes, seat bars, seats and side rails. Stow the vehicle parts as shown in *Figure 3-13*.

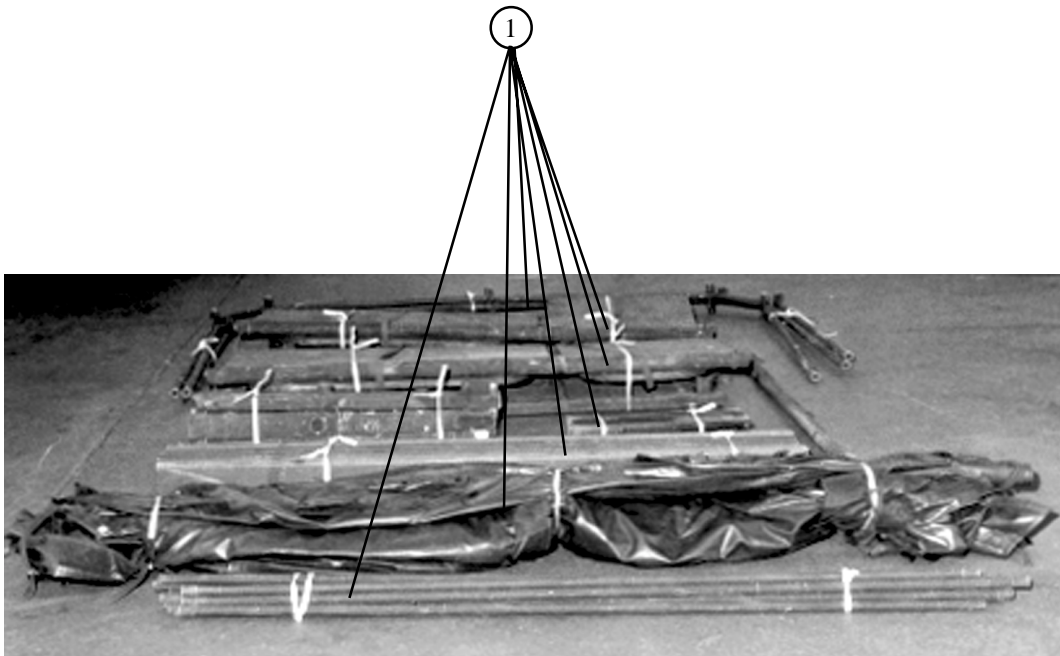

- ① Tie each like item together using 1/2-inch tubular nylon webbing, except the seats. They will be tied into two sets of two seats each.

Figure 3-13. Basic load stowed

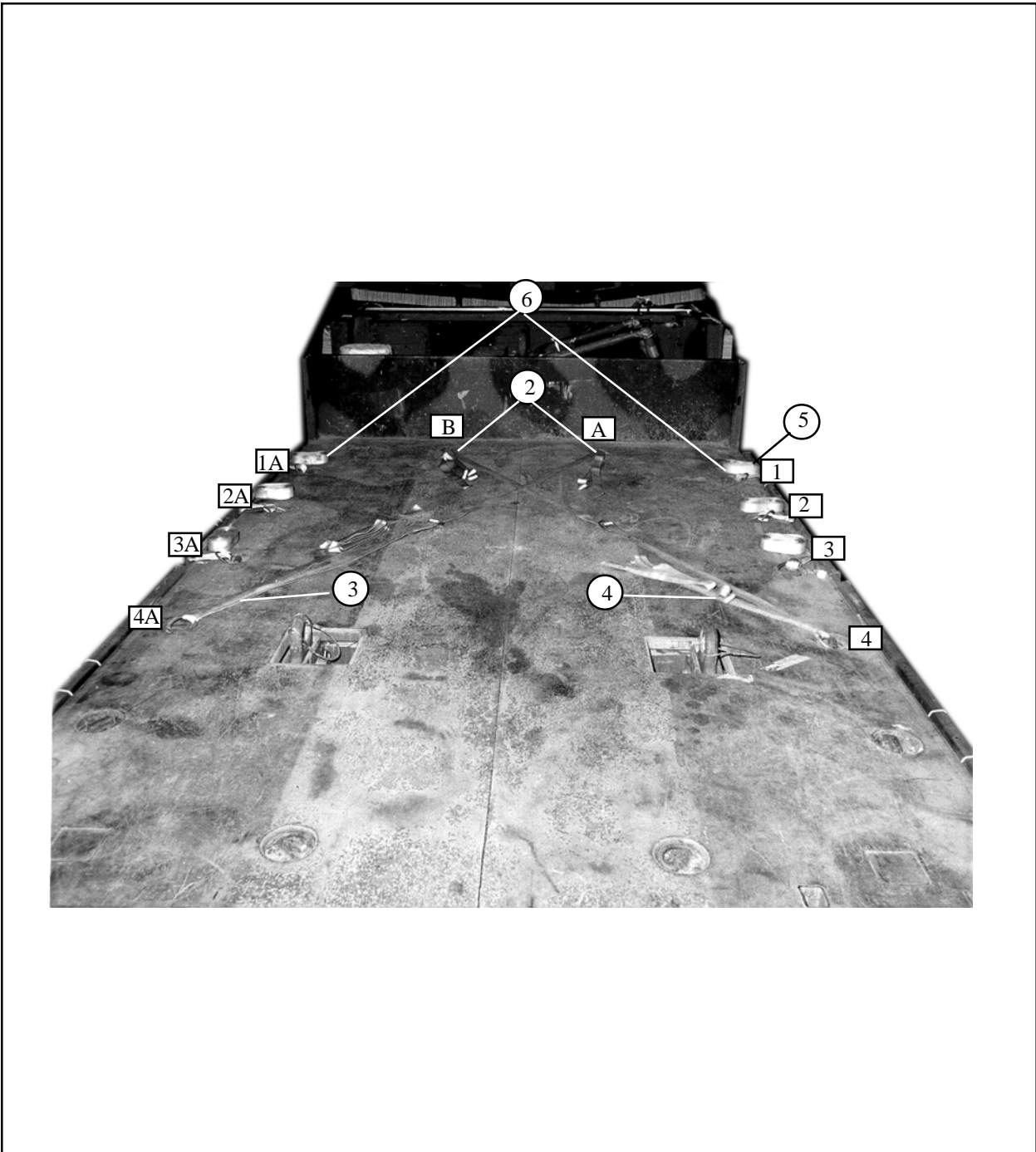

- ② Starting at the front of the truck bed, label the right side truck bed tiedown rings 1 through 4 and the left side 1A through 4A. Label the front center truck rings as A and B.
- ③ Route a 30-foot lashing from bed ring A to 4A .
- ④ Route a 30-foot lashing from bed ring B to 4 .
- ⑤ Route a 15-foot lashing through the truck bed tiedown ring 1, and through it's own D-ring. Lay it to the vehicle's side or roll it up and lay it to the side.
- ⑥ Repeat for truck bed tiedown rings 2, 3, 1A, 2A and 3A.

Figure 3-13. Basic load stowed (Continued)

NOTE: Before positioning roof, make sure that all tiedown rings are laying to the outside of the truck bed.



- ⑦ Position the roof upside down and centered between truck bed tiedown rings 1, 2, 3, 1A, 2A, and 3A, with the lights facing the rear of the vehicle.

Figure 3-13. Basic load stowed (Continued)

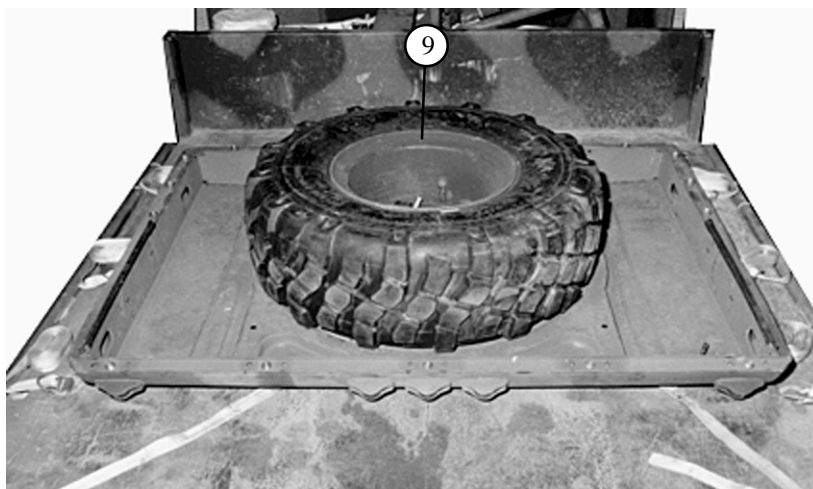
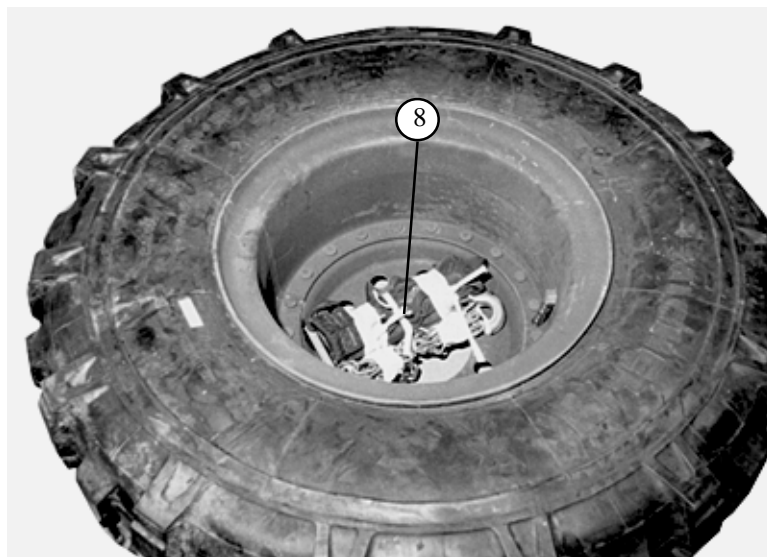

- ⑧ Roll and tape the tire strap. Secure it in the spare tire using 1/2-inch tubular nylon webbing.
- ⑨ Position the spare tire in the center of the roof.

Figure 3-13. Basic load stowed (Continued)

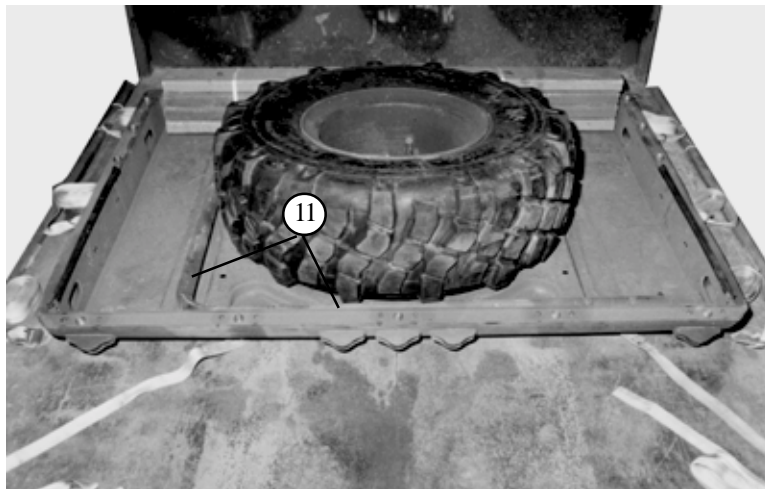
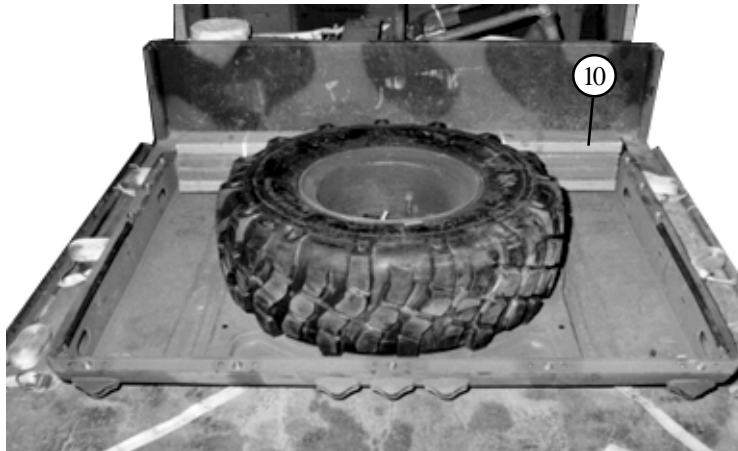

- ⑩ Position the side rails inside the roof in front of the spare tire.
- ⑪ Position the davit to the rear of the spare tire.

Figure 3-13. Basic load stowed (Continued)

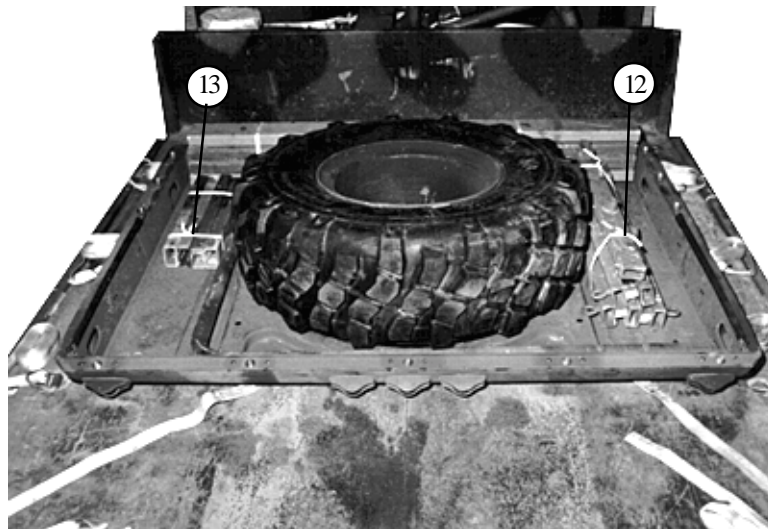

- ⑫ Place the seat bars inside the roof and to the right of the spare tire.
- ⑬ Place the bed stakes inside the roof and to the left of the spare tire.
- ⑭ Place the cargo/troop carrier cover poles in the pole holder in the front of the truck bed. (Not shown)

Figure 3-13. Basic load stowed (Continued)

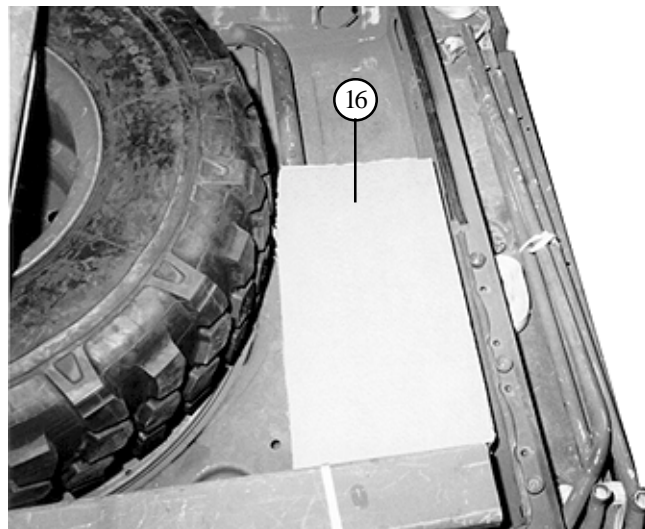
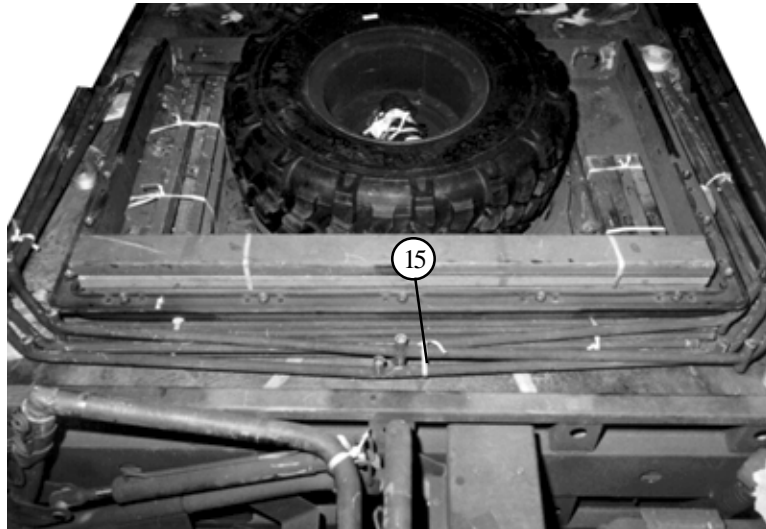

- ⑮ Position the bows in front and around the roof.
- ⑯ Position two pieces of honeycomb on the bed stakes to create a level surface.

Figure 2-13. Basic load stowed (Continued)

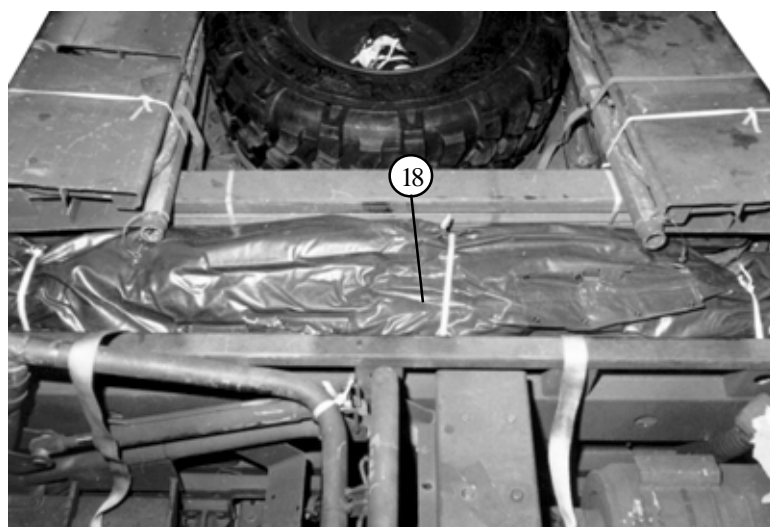
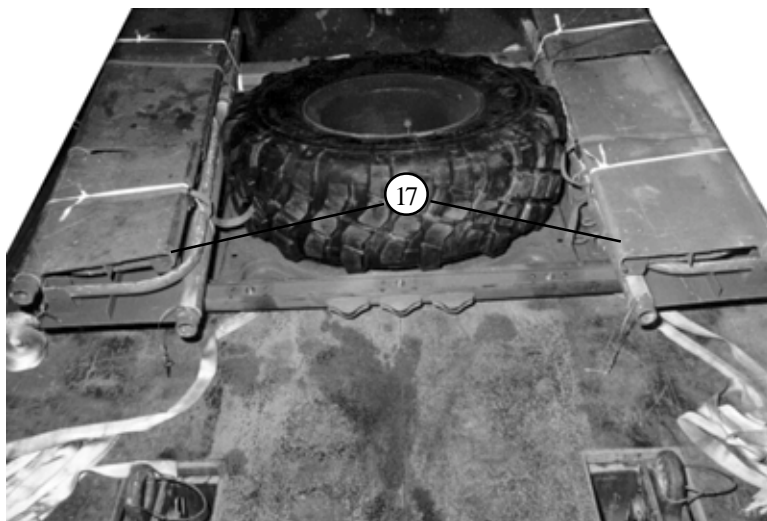

- ①⑦ Position one set of the seats to the left side and one set to the right side of the spare tire.
- ①⑧ Position the cargo/troop carrier cover to the front outside of the roof.

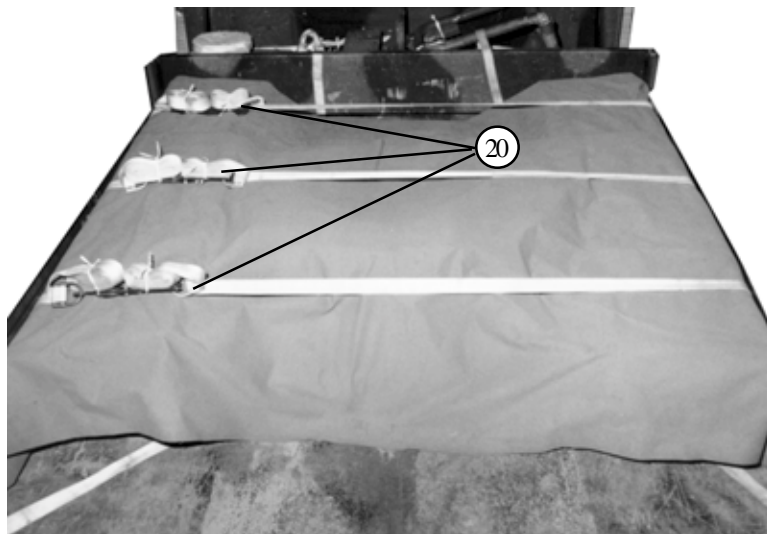
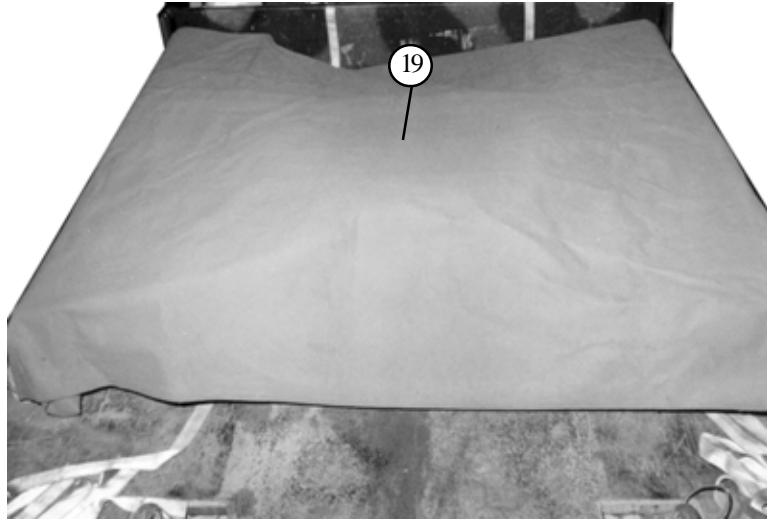

- ① Position the canvas over the basic load.
- ② Secure the lashings on top of the seats on the left side, lashing 1 to 1A, 2 to 2A, and 3 to 3A over the basic load. (Ensure the bows are outside the lashings to prevent bending.)

Figure 3-13. Basic load stowed (Continued)

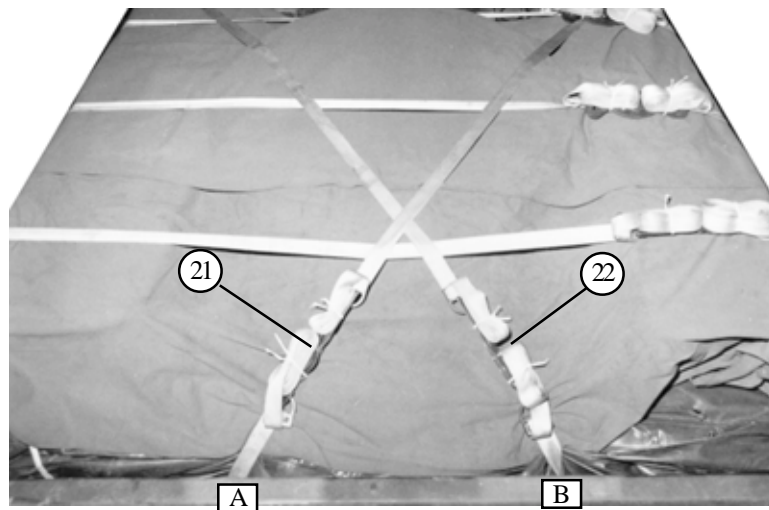

- ②1 Secure the 30-foot lashing routed from truck bed center tiedown rings A to 4A.
- ②2 Secure the 30-foot lashing routed from truck bed center tiedown rings B to 4.
- ②3 Secure the bows to 2 and 2A with 1/2-inch tubular nylon webbing. (Not shown).

Figure 3-13. Basic load stowed (Continued)

3-7. Lifting and Positioning Truck

Install lifting slings on the M1093 truck and position the truck as shown in *Figure 3-15* and as described below.

a. Construct a lifting kit using a large clevis and a doubled 16-foot (2-loop), type XXVI sling attached to the front lifting points with clevis screw pin on each side. Attach a 12-foot (4-loop), type XXVI sling to each rear lifting points with a large clevis.

b. Position the M1093 truck so that the rear of the truck is flush with the front of the platform. All references to front and rear will be according to the platform front and rear once the vehicle is placed on the platform.

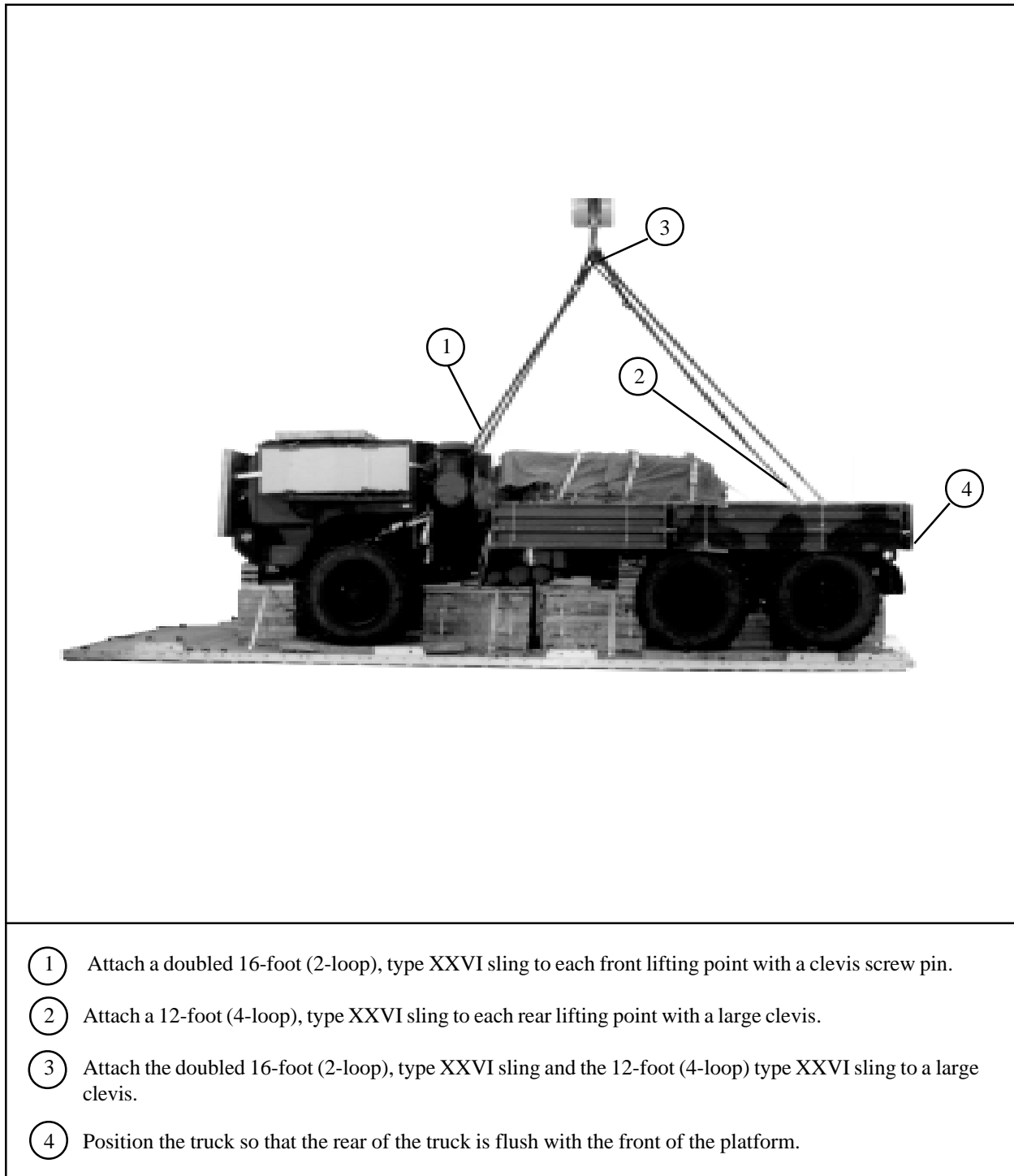
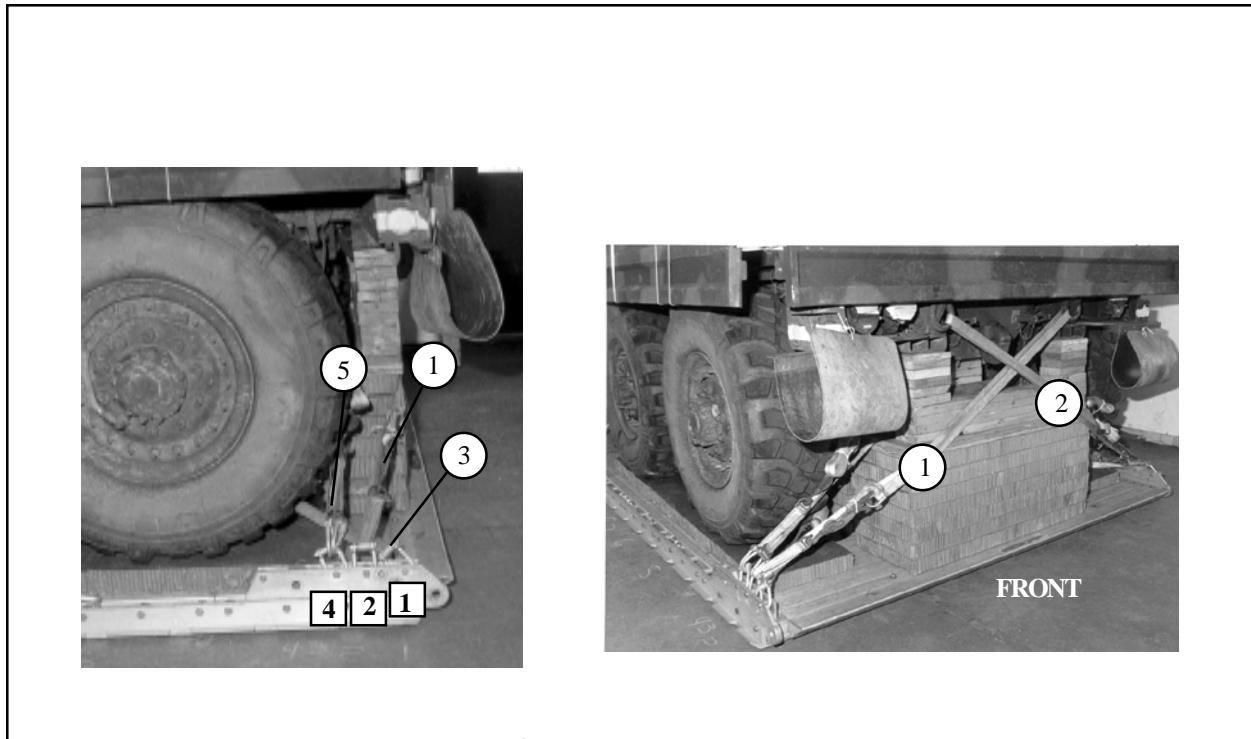

Figure 3-14. Truck positioned on the platform

3-8. Installing Lashings

Install lashings according to FM 10-500-2/TO 13C7-1-5 and as shown in *Figure 3-15*.



Lashing Number	Tiedown Clevis Number	Instructions
1	2	<p>Pass lashing:</p> <p>To left side rear tiedown point.</p> <p>To right side rear tiedown point.</p> <p>Behind the rear wheel, under the axle to tiedown point #4 on the left side.</p> <p>Behind the rear wheel, under the axle to tiedown point #4 on the right side.</p> <p>To the stabilizer right side.</p> <p>To the stabilizer left side.</p>
2	2A	
3	1	
4	1A	
5	4	
6	4A	

Figure 3-15. Truck positioned and lashed to the platform

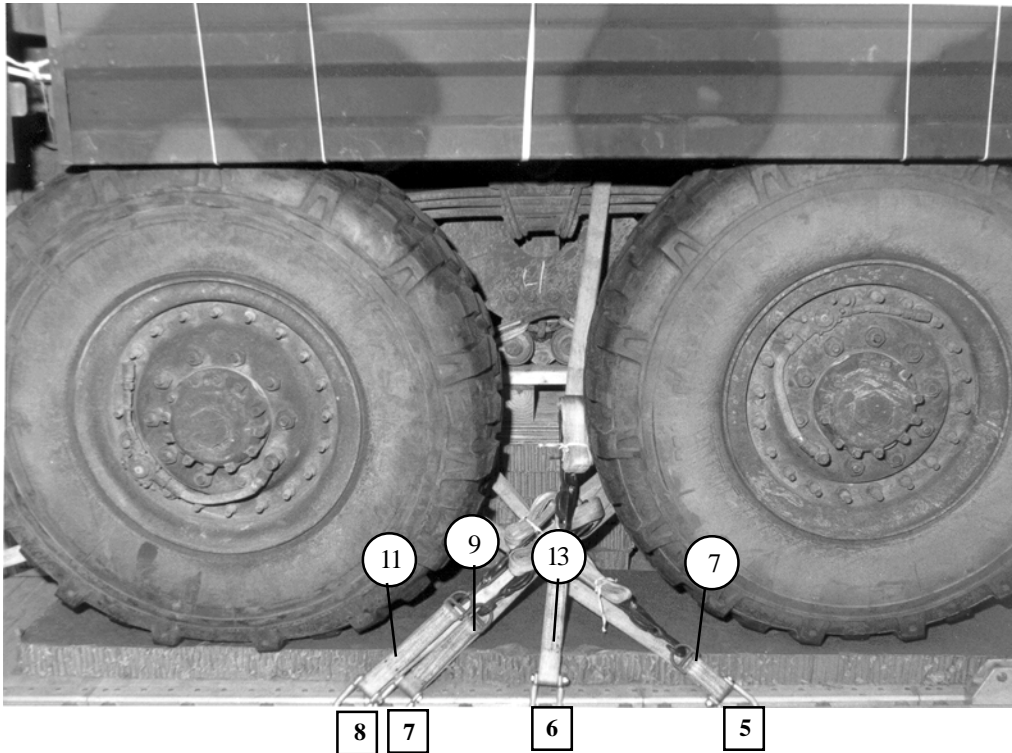

Lashing Number	Tiedown Clevis Number	Instructions
7	5	Pass lashing: Behind the center wheel, under the axle and to tiedown point #1 on the left side.
8	5A	Behind the center wheel, under the axle and to tiedown point #1 on the right side.
9	7	Around right rear axle.
10	7A	Around left rear axle.
11	8	Around right rear axle.
12	8A	Around left rear axle.
13	6	Around leaf spring on right side.
14	6A	Around leaf spring on left side.

Figure 3-15. Truck positioned and lashed to the platform (Continued)

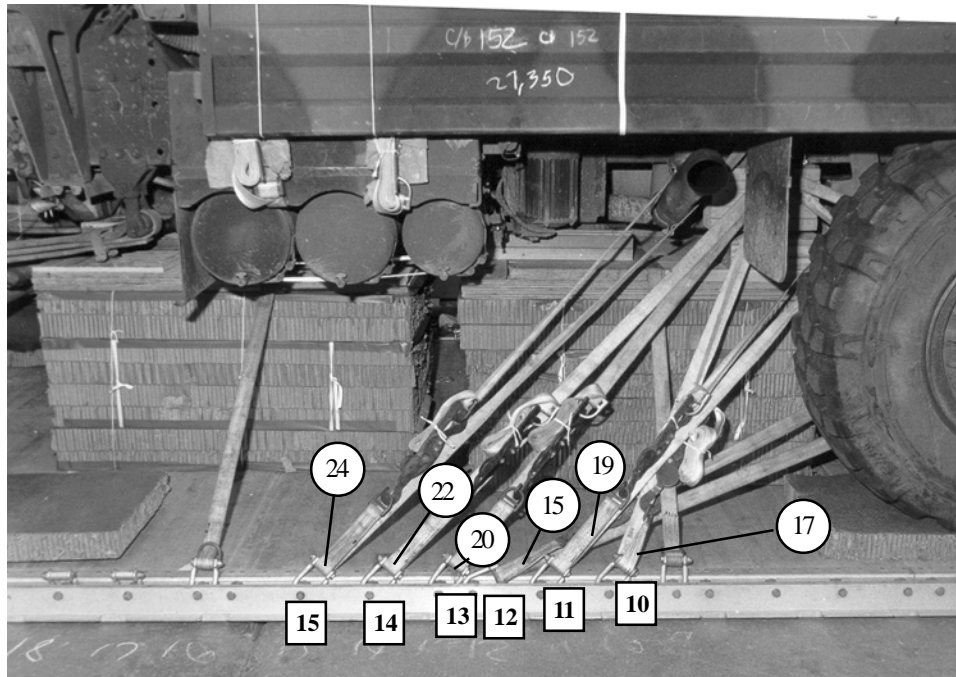

Lashing Number	Tiedown Clevis Number	Instructions
		Pass lashing:
15	12	Through tiedown point #4 on right side, underneath the axle.
16	12A	Through tiedown point #4 on left side, underneath the axle.
17	10	Through tiedown point #1 on right side.
18	10A	Through tiedown point #1 on left side.
19	11	Through tiedown point #3 on right side.
21	11A	Through tiedown point #3 on left side.
20	13	Through tiedown point #1 on right side.
21	13A	Through tiedown point #1 on left side.
22	14	Through tiedown point #1 on right side.
23	14A	Through tiedown point #1 on left side.
24	15	Through tiedown point #2 on right side, splitting exhaust pipe.
25	15A	Through tiedown point #2 on left side.

Figure 3-15. Truck positioned and lashed to the platform (Continued)

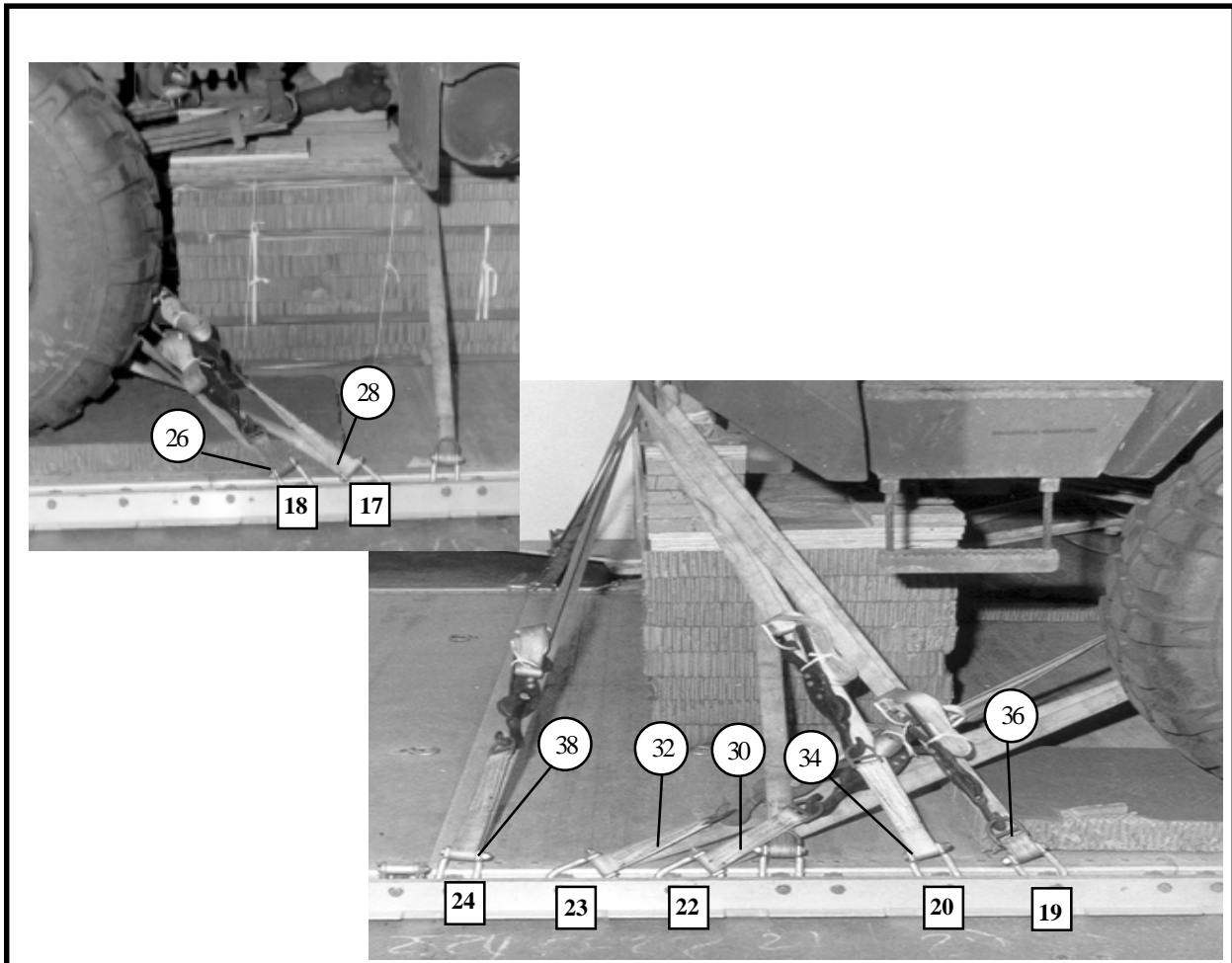

Lashing Number	Tiedown Clevis Number	Instructions
		Pass lashing:
26	18	Around front axle right side.
27	18A	Around front axle left side.
28	17	Around front axle right side.
29	17A	Around front axle left side.
30	22	To front axle right side.
31	22A	To front axle left side.
32	23	To front axle right side.
33	23A	To front axle left side.
34	20	To front shackle left side (DO NOT TIGHTEN).
35	20A	To front shackle right side (DO NOT TIGHTEN).
36	19	To front shackle left side (TIGHTEN LASHING 34, THEN LASHING 36).
37	19A	To front shackle right side (TIGHTEN LASHING 35, THEN LASHING 37).
38	24	To front shackle left side.
39	24A	To front shackle right side.

Figure 3-15. Truck positioned and lashed to the platform (Continued)

3-9. Installing and Safetying Suspension Slings

Install and safety the slings according to FM 10-500-2/TO 13C7-1-5 and as shown in *Figure 3-16*.

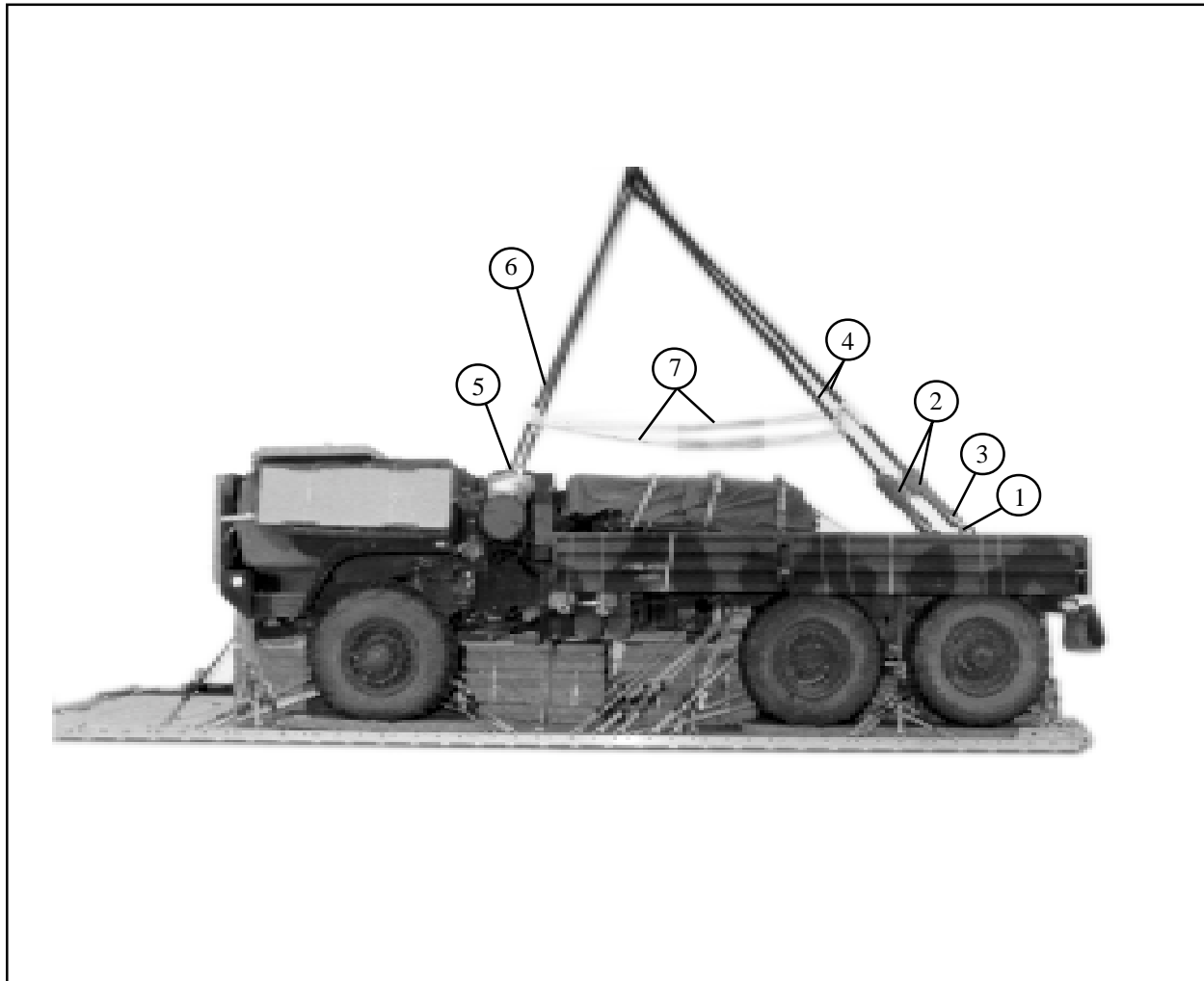

- ① Attach a clevis screw pin to the front lifting point on each side.
- ② Route a 3-foot (4-loop), type XXVI nylon sling through each clevis screw pin clevis.
- ③ Route both running ends of the 3-foot slings through large clevises.
- ④ Attach 12-foot (4-loop), type XXVI nylon slings to each large clevis using bolts and spacers. Pull the clevises up as high as possible, and safety them in place with type III nylon cord to a convenient point on the load.
- ⑤ Bolt a clevis screw pin to each front lifting point.
- ⑥ Attach a 11-foot (4-loop), type XXVI nylon sling to each of the front clevis screw pin.
- ⑦ Raise the slings and install the deadman's tie according to FM 10-500-2/TO 13C7-1-5.

Figure 3-16. Suspension slings installed and safetied

3-10. Stowing Cargo Parachutes

Stow six G-11 cargo parachutes as shown in *Figure 3-17*.

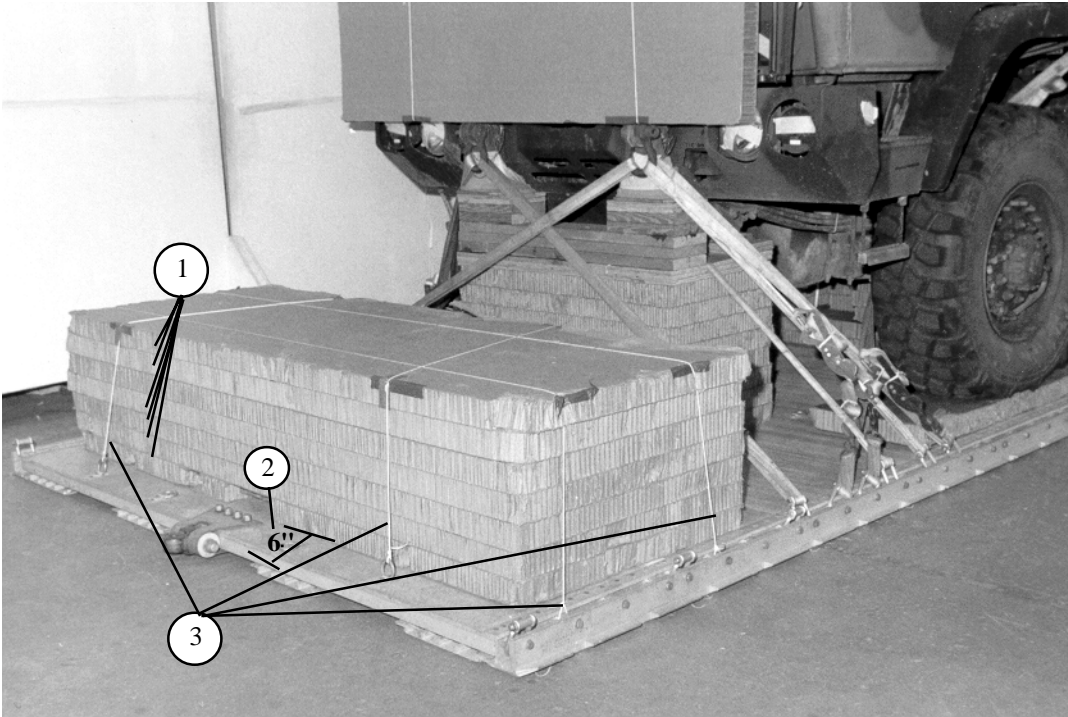

- ① Glue seven 36- by 96-inch pieces of honeycomb together.
- ② Center the honeycomb 6 inches from the rear edge of the platform and tape where need.
- ③ Secure the honeycomb stack in place with four lengths of type III nylon cord attached to the platform tiedown rings and side rail bushings.

Figure 3-17. Parachutes stowed and installed

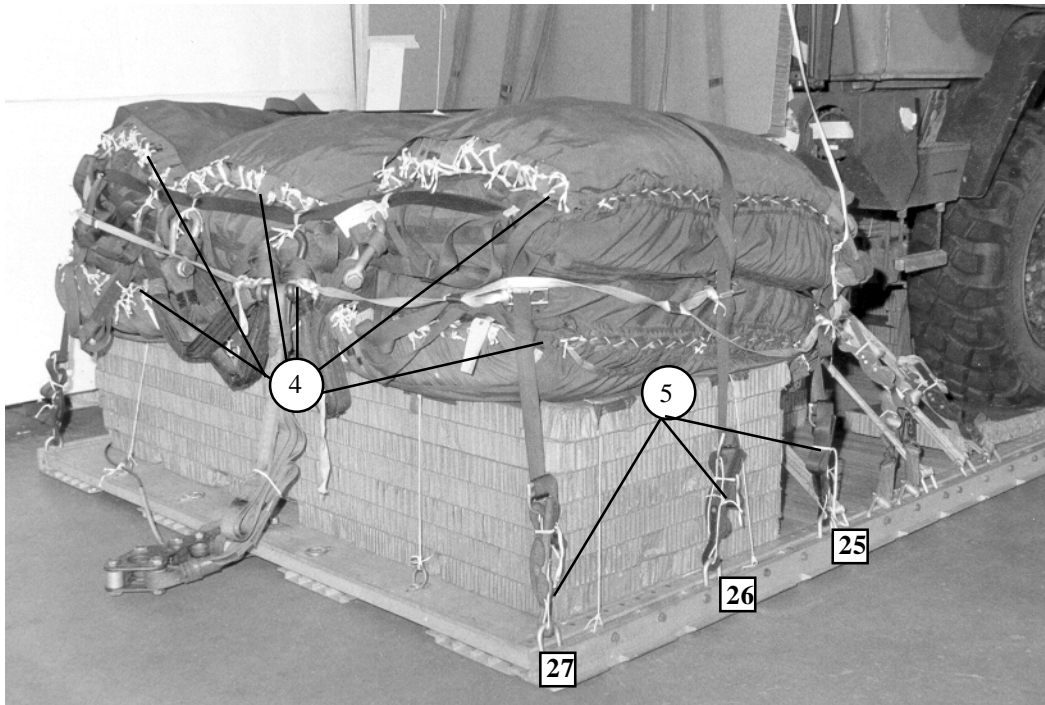

- ④ Prepare, cluster and place six G-11 parachutes on the honeycomb according to FM 10-500-2/TO 13C7-1-5.
- ⑤ Install parachute restraints according to FM 10-500-2/TO 13C7-1-5. Secure the restraints to clevises 25, 25A, 26, 26A, 27 and 27A on the platform.

3-11. Installing Extraction System

Install the components of the extraction force transfer coupling (EFTC) according to FM 10-500-2/TO 13C7-1-5 as shown in *Figure 3-18*.

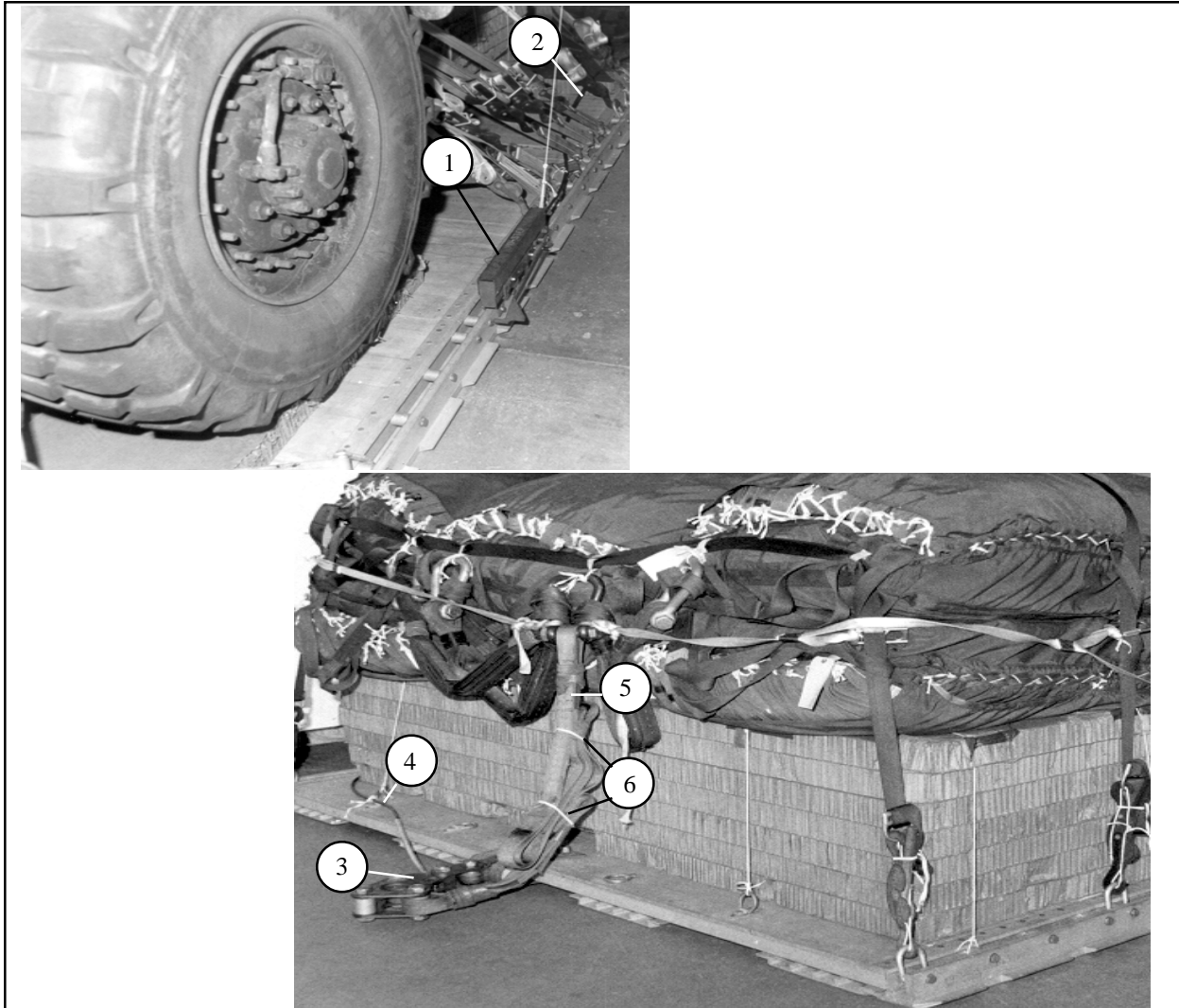

- ① Install the EFTC mounting brackets in the rear mounting holes on the left platform rail.
- ② Attach a 24-foot release cable to the actuator. Install the actuator to the EFTC mounting brackets.
- ③ Install the latch assembly to the extraction bracket. Attach the release cable to the latch assembly.
- ④ Safety the cable with type I, 1/4-inch cotton webbing to the platform bushings or deck rings.
- ⑤ Attach one end of a 9-foot (2-loop), type XXVI nylon sling, for use as a deployment line. Attach the other end to the extraction link.
- ⑥ S-fold the slack and secure the folds with type I, 1/4-inch cotton webbing according to FM 10-500-2/TO 13C7-1-5.

Figure 3-18. Extraction system installed

3-12. Installing Release System

Install an M-2 cargo parachute release according to FM 10-500-2/TO 13C7-1-5 and as shown in *Figure 3-19*.

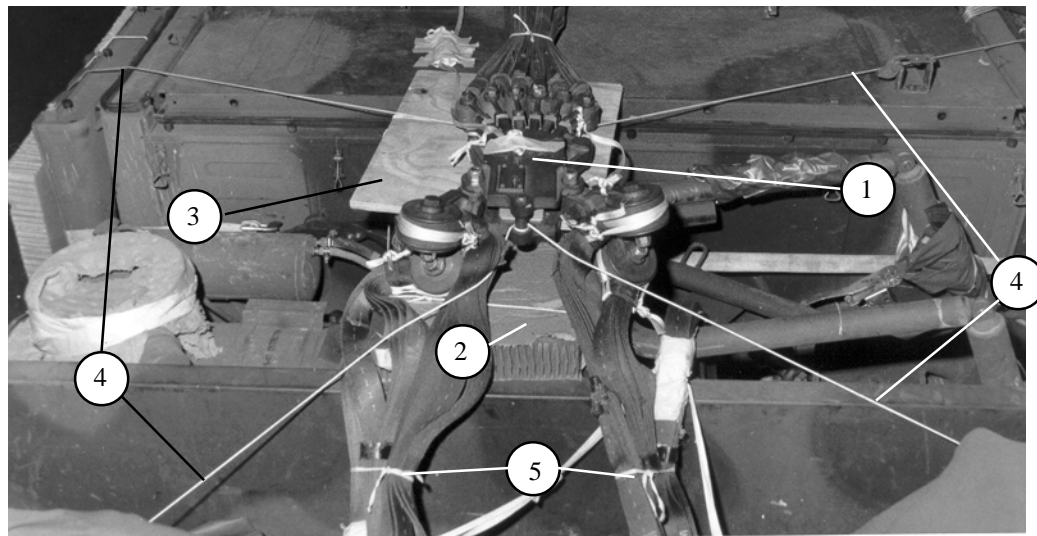

- ① Prepare an M-2 release according to FM 10-500-2/TO 13C7-1-5.
- ② Place two 20- by 8-inch pieces of honeycomb on each side of the spare tire mount.
- ③ Place a 20- by 20-inch piece of 1/4-inch plywood on top of the honeycomb and place the M-2 release on top of the plywood.
- ④ Safety it to convenient places on the load according to FM 10-500-2/TO 13C7-1-5.
- ⑤ Fold and tie any slack in the suspension slings.

Figure 3-19. Parachute release installed

3-13. Installing Provisions for Emergency Restraints

Select and install provisions for emergency restraints according to the emergency restraint requirements table found in FM 10-500-2/TO 13C7-1-5.

3-14. Placing Extraction Parachute

Select the extraction parachute and extraction parachute line needed using the extraction parachute and extraction line requirements table found in FM 10-500-2/TO 13C7-1-5.

3-15. Marking the Rigged Load

Mark the rigged load according to FM 10-500-2/TO 13C7-1-5 and as shown in *Figure 3-19*. If the load varies from the one shown, the weight, height, CB, tip-off curve and parachute requirements must be recomputed.

3-16. Equipment Required

Use the equipment listed in *Table 3-2* to rig this load.

CAUTION

**Make the final rigger inspection required by
FM 10-500-2/TO 13C7-1-5 before the load
leaves the rigging site.**



CB

RIGGED LOAD DATA

Weight: Load shown	27,318 pounds
Minimum load allowed	27,000 pounds
Maximum load allowed	28,000 pounds
Height	100 inches
Width	108 inches
Length	354 inches
Overhang: Front	0 inches
Rear	0 inches
CB (from front edge of platform)	150 inches
Extraction System	EFTC

Figure 3-19. M1093, 5-Ton standard cargo truck rigged for low-velocity airdrop

Table 3-2. Equipment required for rigging the M1093, 5-ton cargo truck for low-velocity airdrop on a type V platform

National Stock Number	Item	Quantity
8040-00-273-8713	Adhesive, paste, 1-gal	As required
N/A	Bolt, (washers and nuts) 1/2- by 10-in	4
1670-01-035-6054	Bridle, extraction line bag (Use with extraction line bag)	1
4030-00-432-2516	Clevis, screw pin	4
4030-00-090-5354	Clevis, suspension, 1-in (large)	9
4020-00-240-2164	Cord, nylon, type III, 550-lb	As required
8305-00-242-3593	Cloth, cotton duck, 60-in	As required
1670-00-434-5787	Coupling, airdrop extraction force transfer cable, 24-ft	1
1670-00-360-0328	Cover, clevis, large	6
8135-00-664-6958	Cushioning material, packaging, (cellulose wadding)	As required
8305-00-958-3685	Felt, 1/2-in thick	As required
1670-01-183-2678	Leaf, extraction line	2
	Line, extraction line, type XXV Inylon webbing	
5510-00-220-6148	60-ft (1-loop), drogue	1
1670-01-062-6313	60-ft (6-loop), (C-130 aircraft)	1
1670-01-220-6248	120-ft (6-loop), (C-141 and C-5 aircrafts)	1
1670-01-468-9178	140-ft (6-loop), (C-17 aircraft)	1

Table 3-2. Equipment required for rigging the M1093, 5-ton cargo truck for low-velocity airdrop on type V platform (continued)

National Stock Number	Item	Quantity
	Link assembly:	
1670-00-006-2752	Four-point:	1
	Two-point:	1
5305-00-435-8994	Bolt, 1-in diam, 4-in long	(2)
5310-00-232-5165	Nut, 1-in	(2)
1670-00-003-1954	Plate, side, 5 1/2-in	(2)
5365-00-007-3414	Spacer, large	(2)
1670-00-783-5988	Type IV	1
1670-01-247-2389	Link, suspension tandem	2
	Load spreader for honeycomb stack 1:	
	Lumber:	
5510-00-220-6148	2- by 6- by 8-in	10
	2- by 6- by 10-in	4
	2- by 6- by 33-in	3
5510-00-220-6246	2- by 8- by 45-in	4
5530-00-129-7777	Plywood, 1/2-in:	
	5 1/2- by 8-in	4
	5 1/2- by 10-in	1

Table 3-2. Equipment required for rigging the M1093, 5-ton cargo truck for low-velocity airdrop on a type V platform (continued)

National Stock Number	Item	Quantity
5530-00-128-4981	Plywood, 3/4-in: 18- by 48-in Load spreader for honeycomb stack 2:	3
5510-00-220-6246	Lumber, 2- by 8- by 20-in	3
5530-00-128-4981	Plywood, 3/4-in: 7 1/2- by 20-in 20- by 43-in Load spreader for honeycomb stack 3:	1 3
5510-00-220-6146	Lumber, 2- by 4- by 11-in	2
5510-00-220-6274	Lumber, 4- by 4- by 48-in	2
5510-00-128-4981	Plywood, 3/4-in: 6- by 11-in 18- by 48-in Load spreader for honeycomb stack 4:	2 3
5510-00-220-6148	Lumber:	
5510-00-220-6148	2- by 6- by 21-in (without winch), (with winch)	2 (3)
5510-00-220-6250	2- by 6- by 48-in	1
5510-00-220-6250	2- by 12- by 12-in	4
5510-00-220-6250	2- by 12- by 38 1/2- in	2
5510-00-128-4981	Plywood 3/4-in: 5 1/2- by 21-in 11 1/2- by 12-in 44- by 48-in	2 2 3

Table 3-2. Equipment required for rigging the M1093, 5-ton cargo truck for low-velocity on type V airdrop platform (continued)

National Stock Number	Item	Quantity
	Load spreader for honeycomb stack 5:	
5510-00-220-6148	Lumber, 2- by 8- by 26 1/2-in	2
5530-00-128-4981	Plywood, 3/4-in:	
	7 1/2- by 8-in	1
	7 1/2- by 26 1/2-in	1
	6- by 8-in	1
	8- by 16-in	1
	10- by 10-in	1
	12- by 14-in	6
	46- by 48-in	3
	Load spreader for honeycomb stack 6:	
	Lumber:	
5510-00-220-6148	2- by 8- by 12-in	4
	2- by 8- by 43-in	3
5530-00-128-4981	Plywood, 3/4-in:	
	7- by 14-in	4
	7 1/2- by 12-in	4
	24- by 43-in	3
	Nail, steel wire, common:	
5315-00-010-4659	8d	As required
5315-00-753-3885	16d	As required
1670-00-753-3928	Pad, energy-dissipating, honeycomb,	
	3- by 36- by 96-in:	55 sheets
	8- by 20-in	(2)
	11- by 16-in	(7)
	12- by 36-in	(12)
	12- by 44-in	(2)
	12- by 46-in	(2)
	18- by 44-in	(12)
	18- by 46-in	(12)
	18- by 48-in	(12)
	18- by 60-in	(2)
	18- by 74-in	(2)
	18- by 96-in	(2)

Table 3-2. Equipment required for rigging the M1093, 5-ton cargo truck for low-velocity airdrop on a type V platform (continued)

National Stock Number	Item	Quantity
	20- by 43-in	(5)
	24- by 43-in	(8)
	36- by 44-in	(2)
	36- by 46-in	(2)
	36- by 80-in	(1)
	36- by 96-in	(8)
1670-01-016-7841	Parachute, cargo: G-11C	6
	Parachute, cargo extraction:	
1670-00-040-8135	28-ft	2
1670-01-063-3715	15-ft	1
	Platform, AD, type V, 28-ft	1
1670-01-353-8425	Bracket assembly comp	(1)
1670-01-162-2372	Clevis, load tiedown	(52)
1670-01-353-8424	Extraction bracket assembly	(1)
1670-01-162-2381	Tandem link	(2)
1670-01-097-8817	Release, cargo parachute, M-2	1
	Sling, cargo, airdrop:	
	For deployment line:	
1670-01-062-6304	9-ft (2-loop), type XXVI nylon webbing	1
	For lifting:	
1670-01-062-6307	12-ft (4-loop), type XXVI nylon webbing	2
1670-01-063-7761	16-ft (2-loop), type XXVI nylon webbing	1
	For suspension:	
1670-01-062-6306	3-ft (4-loop), type XXVI nylon webbing	2
1670-01-062-6310	11-ft (4-loop), type XXVI nylon webbing	2
1670-01-062-6307	12-ft (4-loop), type XXVI nylon webbing	2

Table 3-2. Equipment required for rigging the M1093, 5-ton cargo truck for low-velocity airdrop on a type V platform (continued)

National Stock Number	Item	Quantity
1670-01-062-6311	For riser extension: 120-ft (2-loop), type XXVI nylon webbing	6
5340-00-040-8219	Strap, parachute release, multi-cut with 3 knives	2
	Truck preparation	
	Lumber:	
5510-00-220-6146	2- by 4- by 6	4
5510-00-220-6148	2- by 6- by 6	3
	2- by 6- by 13	10
5510-00-220-6274	4- by 4- by 6	2
	4- by 4- by 15	2
1670-00-753-3928	Pad, energy-dissipating, honeycomb, 3-by 36- by 96-in: 4- by 6-in 18- by 60-in 36- by 80-in 36- by 96-in	4 sheets (1) (2) (1) (1)
5530-00-128-4981	Plywood, 3/4-in: 10- by 10-in	1
7510-00-266-5016	Tape, adhesive, 2-in (masking)	As required
7510-00-074-5124	Tape, pressure sensitive, 2-in (cloth, back)	As required
1670-00-937-0271	Tiedown assembly, 15-ft	80
	Webbing:	
8305-00-268-2411	Cotton, 80-lb	As required
8305-00-082-5752	Nylon, tubular, 1/2-in, 1,000-lb natural	As required
8305-00-263-3591	Type VIII	As required

CHAPTER 4

RIGGING M1094, 5-TON DUMP TRUCK ON A 28-FOOT TYPE V PLATFORM FOR LOW-VELOCITY AIRDROP

RIGGING M1094, 5-TON DUMP TRUCK

4-1. Description of Load

The M1094, 5-ton dump truck (*Figure 4-1*) is rigged on a 28-foot, type V airdrop platform with seven G-11C cargo parachutes and other items of airdrop equipment.

The load consists of the M1094, 5-ton dump truck and a 2,000 pound ballast box. This load is 95 inches in height, 108 inches in width, 354 inches in length and has a rigged weight of 34,100 pounds.

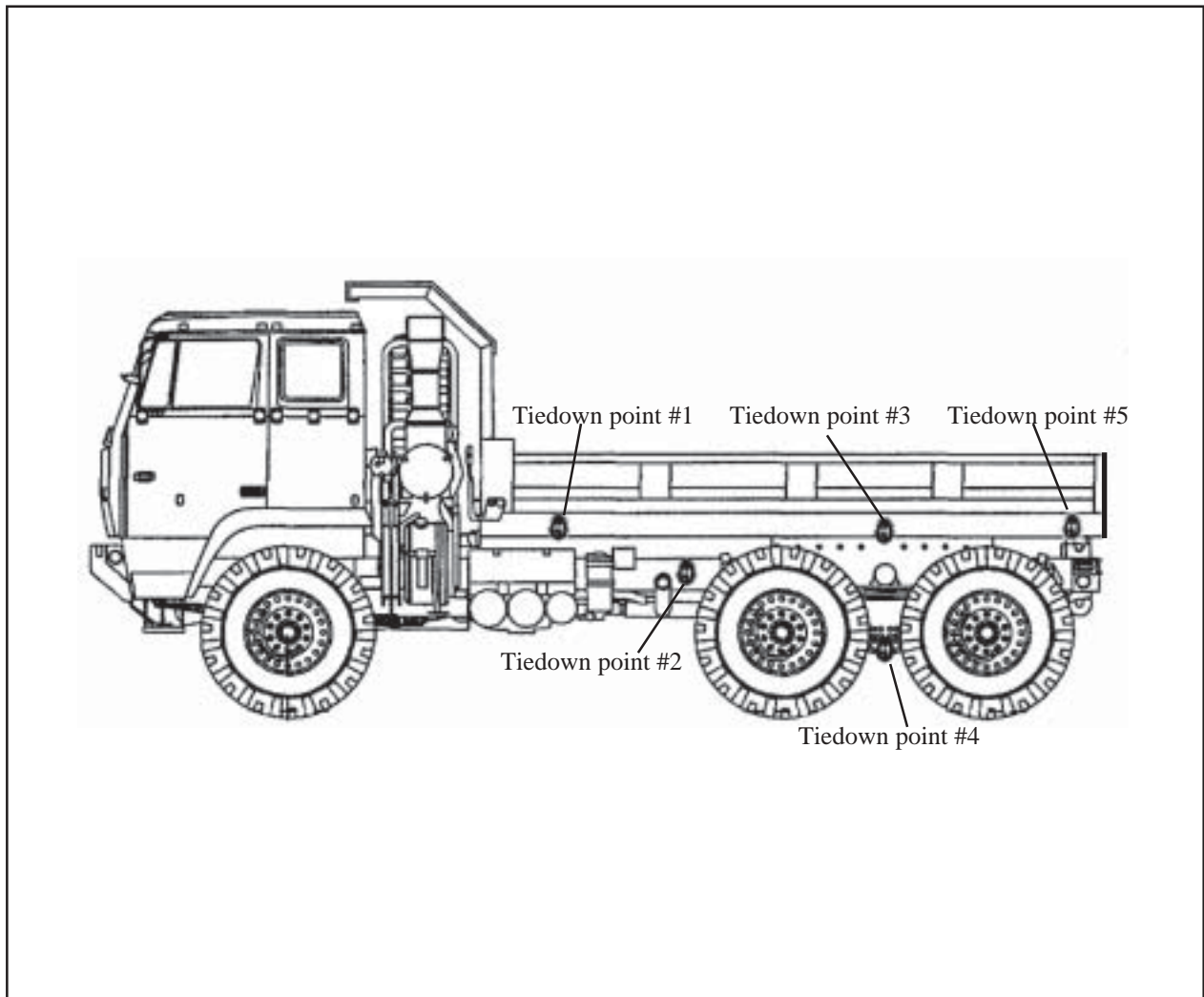

Figure 4-1. M1094, 5-ton dump truck

4-2. Preparing Platform

Prepare a 28-foot, type V platform as described below and as shown in

Figure 4-2.

- NOTES:**
1. Measurements given in this section are from the front edge of the platform NOT from the front edge of the nose bumper.
 2. The "triple" clevis installations provide two tiedown points for the same attachment hole.

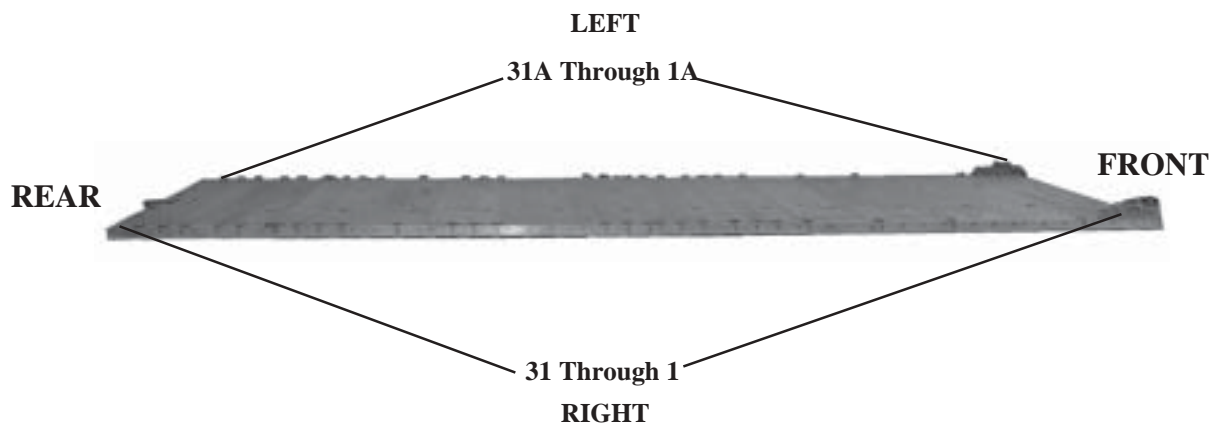

Step:

1. Inspect, or assemble and inspect, a 28-foot, type V airdrop platform as outlined in TM 10-1670-268-20&P/TO 13C7-52-22.
2. Install a tandem link on the front of each platform side rail using holes 1, 2, and 3.
3. Attach clevises to each tandem link using bushings 1, 2, and 3 (tripled).
4. Starting at the front of each platform side rail, install clevises using bushings bolted to holes 5, 12, 16, 20, 22, 23, 24, 26, 27, 28, 29, 30, 31, 37, 38, 39, 42, 45, 46, 47, 48 (tripled), 50, 51, 53, 54, and 55.
5. Starting at the front of the platform, number the clevises bolted to the right rail 1 through 31 and the left rail 1A through 31A.

Figure 4-2. Platform prepared

4-3. Preparing Honeycomb Stacks

Use the material in *Table 4-1* to prepare 11 honeycomb stacks as shown in *Figures 4-3 through 4-11*.

NOTE: On all stacks the plywood must be cut to fit lumber.
EXAMPLE: An 11 1/2- by 24 inch piece of plywood sits on a 2- by 12- by 24-inch piece of lumber but hangs over a 1/2 inch on the 11 1/2 inch side. Cut it to 11 by 24 inches to insure it fits. This is not due to improper measurements but to the fact that lumber varies in true sizes.

Table 4-1. Material needed to build honeycomb stacks

Stack Number	Pieces	Width (Inches)	Length (Inches)	Material	Instructions
1	7	48	18	Honeycomb	See <i>Figure 4-3</i> .
	3	48	18	3/4-inch plywood	
	4	2- by 6	45	Lumber	
	10	2- by 6	8	Lumber	
	4	8	5 1/2	1/2-inch plywood	
	3	2- by 6	33	Lumber	
	4	2- by 6	10	Lumber	
	1	10	5 1/2	1/2-inch plywood	
2	5	51	20	Honeycomb	See <i>Figure 4-4</i> .
	3	51	20	3/4-inch plywood	
	3	2- by 8	20	Lumber	
	1	7 1/2	20	3/4-inch plywood	
3	5	48	18	Honeycomb	See <i>Figure 4-5</i> .
	3	48	18	3/4-inch plywood	
	2	4- by 4	48	Lumber	
	2	2- by 4	11	Lumber	
	2	11	6	3/4-inch plywood	
4 without winch with winch	2	36	44	Honeycomb	See <i>Figure 4-6</i> .
	2	12	44	Honeycomb	
	12	18	44	Honeycomb	
	6	12	36	Honeycomb	
	3	48	44	3/4-inch plywood	
	1	2- by 6	48	Lumber	
	4	2- by 6	21	Lumber	
	5	2- by 6	21	Lumber	
	2	5 1/2	21	3/4-inch plywood	
	4	2- by 12	12	Lumber	
	2	12	11 1/2	3/4-inch plywood	
	2	2- by 12	38 1/2	Lumber	

Table 4-1. Material needed to build honeycomb stacks (continued)

Stack Number	Pieces	Width (Inches)	Length (Inches)	Material	Instructions
5	2	36	46	Honeycomb	See Figure 4-7.
	2	12	46	Honeycomb	
	12	18	46	Honeycomb	
	6	12	36	Honeycomb	
	3	48	46	3/4-inch plywood	
	6	14	12	3/4-inch plywood	
	2	2- by 8	26 1/2	Lumber	
	1	7 1/2	26 1/2	3/4-inch plywood	
	1	7 1/2	8	3/4-inch plywood	
	1	10	10	3/4-inch plywood	
	1	8	6	3/4-inch plywood	
1	8	16	3/4-inch plywood		
6	5	48	18	Honeycomb	See Figure 4-8.
	2	48	18	3/4-inch plywood	
	2	2- by 6	18	Lumber	
	6	18	5 1/2	3/4-inch plywood	
7	8	43	24	Honeycomb	See Figure 4-9.
	3	43	24	3/4-inch plywood	
	3	2- by 8	43	Lumber	
	4	2- by 8	12	Lumber	
	4	7 1/2	12	3/4-inch plywood	
	4	14	7	3/4-inch plywood	
8	1	18	96	Honeycomb	See Figure 4-10.
9	1	18	96	Honeycomb	See Figure 4-10.
10	1	18	74	Honeycomb	See Figure 4-11.
11	1	18	74	Honeycomb	See Figure 4-11.

Note: This drawing is not drawn to scale.

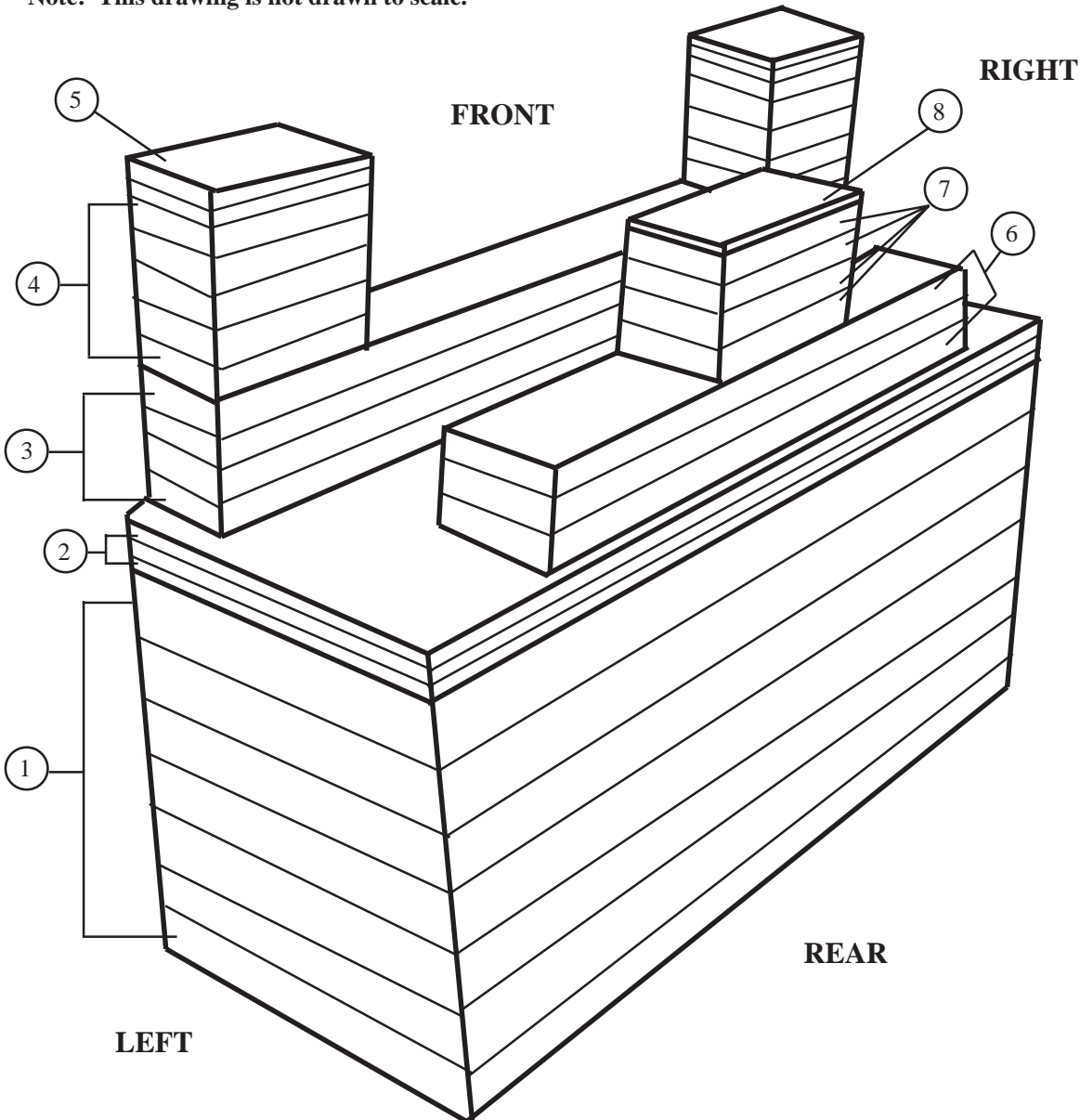

- ① Glue seven 48- by 18-inch pieces of honeycomb together to form a base.
- ② Glue and nail three 48- by 18-inch pieces of 3/4-inch plywood together. Glue the plywood to the top of the base.
- ③ Glue and nail four 2- by 6- by 45-inch pieces of lumber together. Center, glue, and nail the lumber flush with the front edge of the plywood.
- ④ Glue and nail two 5 piece stacks of 2- by 6- by 8-inch lumber. Glue and nail one stack on the right edge of the lumber and the other stack on the left edge of the 45-inch lumber.
- ⑤ Glue and nail two 2 piece stacks of 8- by 5 1/2-inch pieces of 1/2-inch plywood. Glue and nail on the top right side of each 2- by 6- by 8-inch piece of lumber in step 4.
- ⑥ Glue, center and nail 1-inch from the rear of the 45-inch stack, three 2- by 6- by 33-inch pieces of lumber.
- ⑦ Glue, center and nail four 2- by 6- by 10-inch pieces of lumber on the 2- by 6- by 33-inch pieces of lumber.
- ⑧ Glue, center and nail a 10- by 5 1/2-inch piece of 1/2-inch plywood on top of the 2- by 6- by 10-inch pieces of lumber.

Figure 4-3. Stack 1 prepared

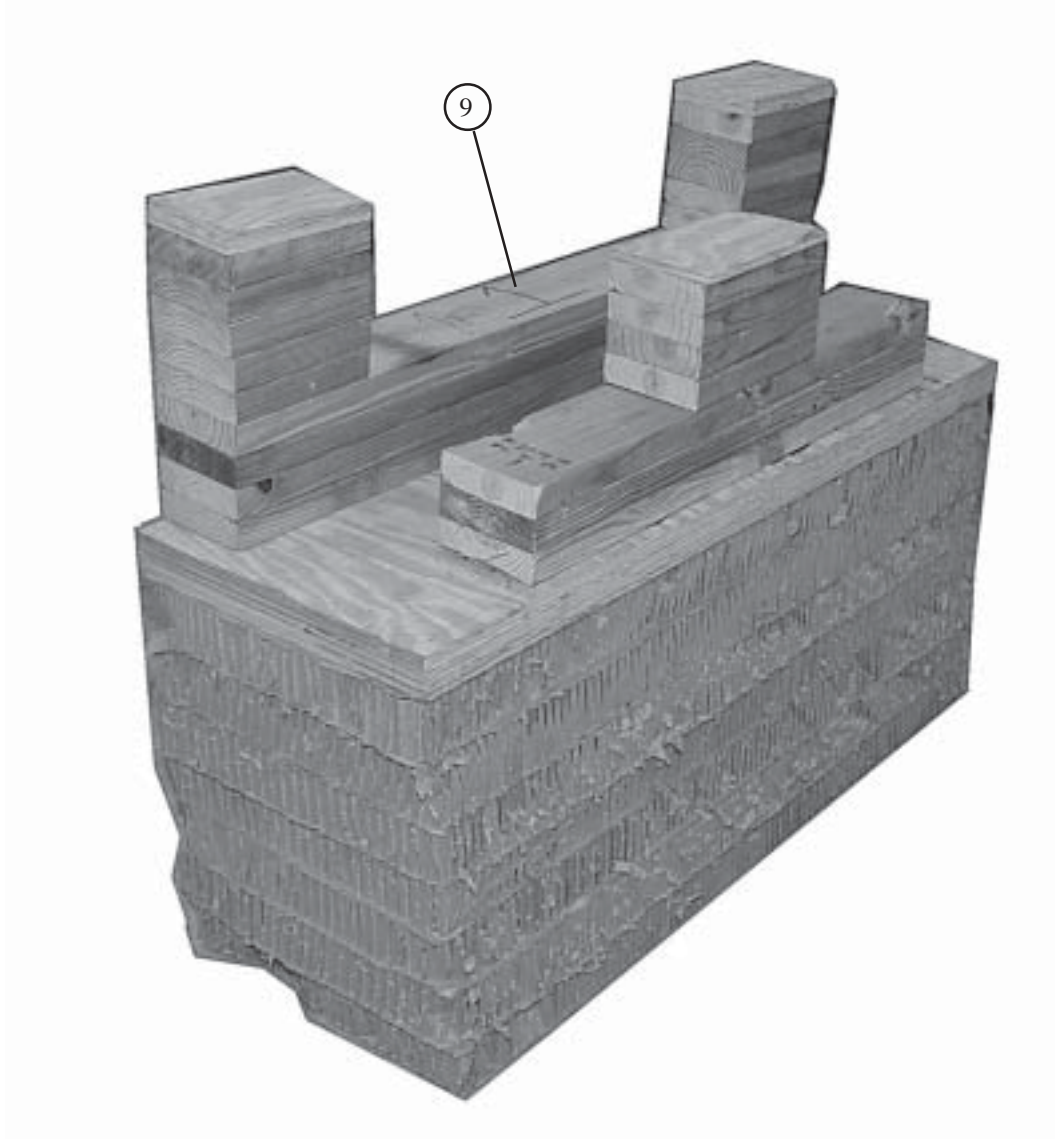

⑨ Glue the completed lumber to the honeycomb base.

Note: This drawing is not drawn to scale.

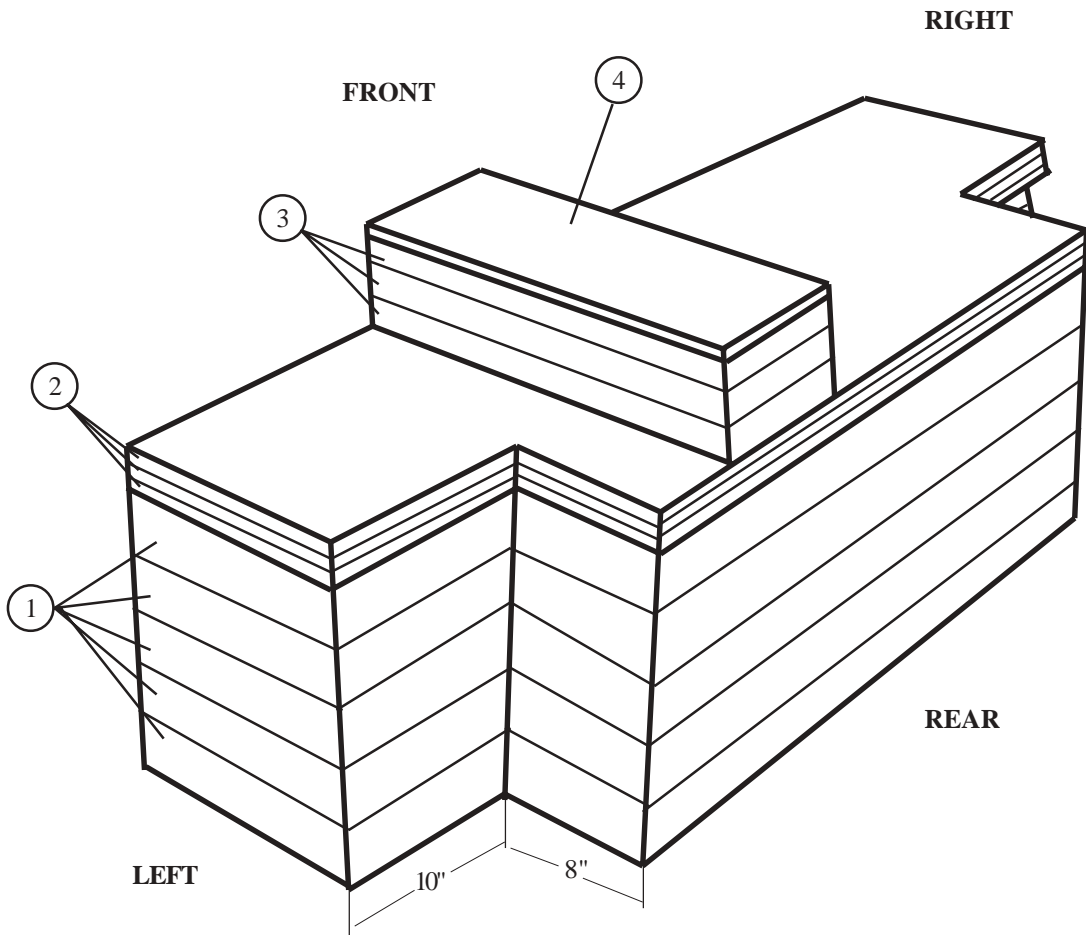

- ① Glue five 51- by 20-inch pieces of honeycomb together to form the base. Make an 8- by 10-inch cutout on each of the rear edges.
- ② Glue, center, and nail three 51- by 20-inch pieces of 3/4-inch plywood on top of the base. Make an 8 by 10-inch cutout on each of the rear edges.
- ③ Glue and nail three 2- by 8- by 20-inch pieces of lumber 13 inches from the left edge of the plywood.
- ④ Glue and nail a 7 1/2- by 20-inch piece of 3/4-inch plywood on top of the three 2- by 8- by 20-inch pieces of lumber.

Figure 4-4. Stack 2 prepared

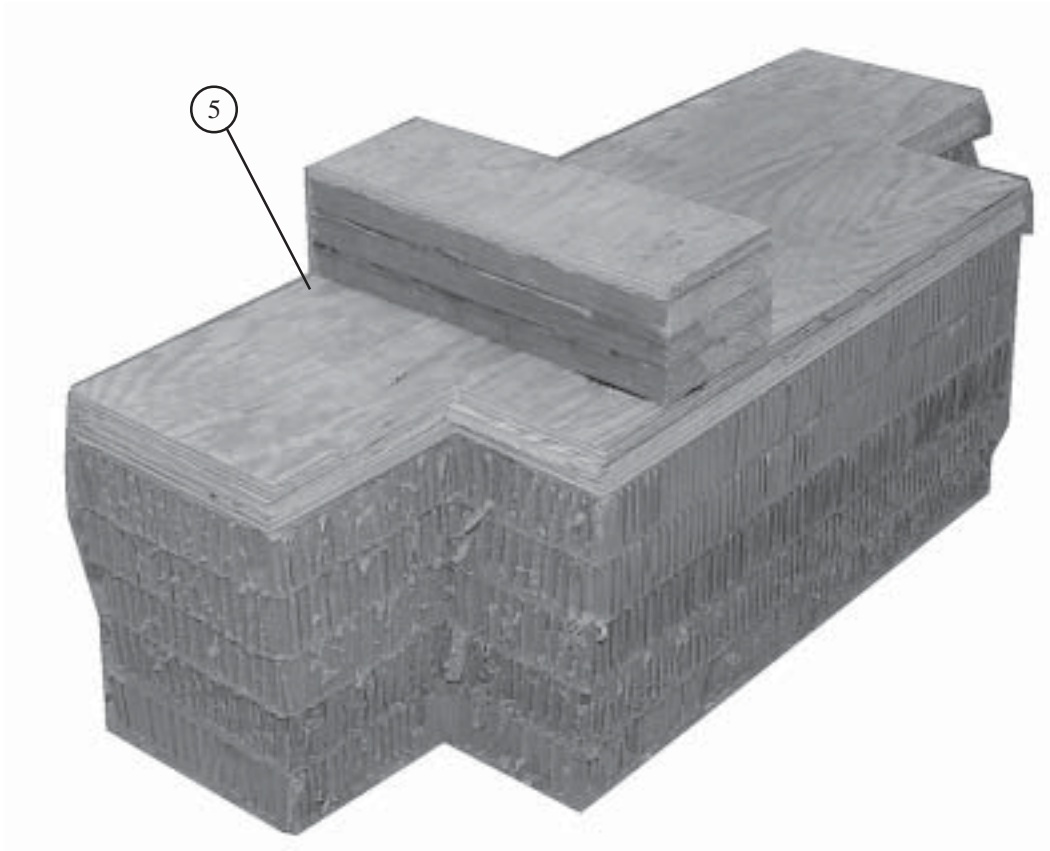

⑤ Glue the completed lumber to the honeycomb base.

Figure 4-4. Stack 2 prepared (Continued)

Note: This drawing is not drawn to scale.

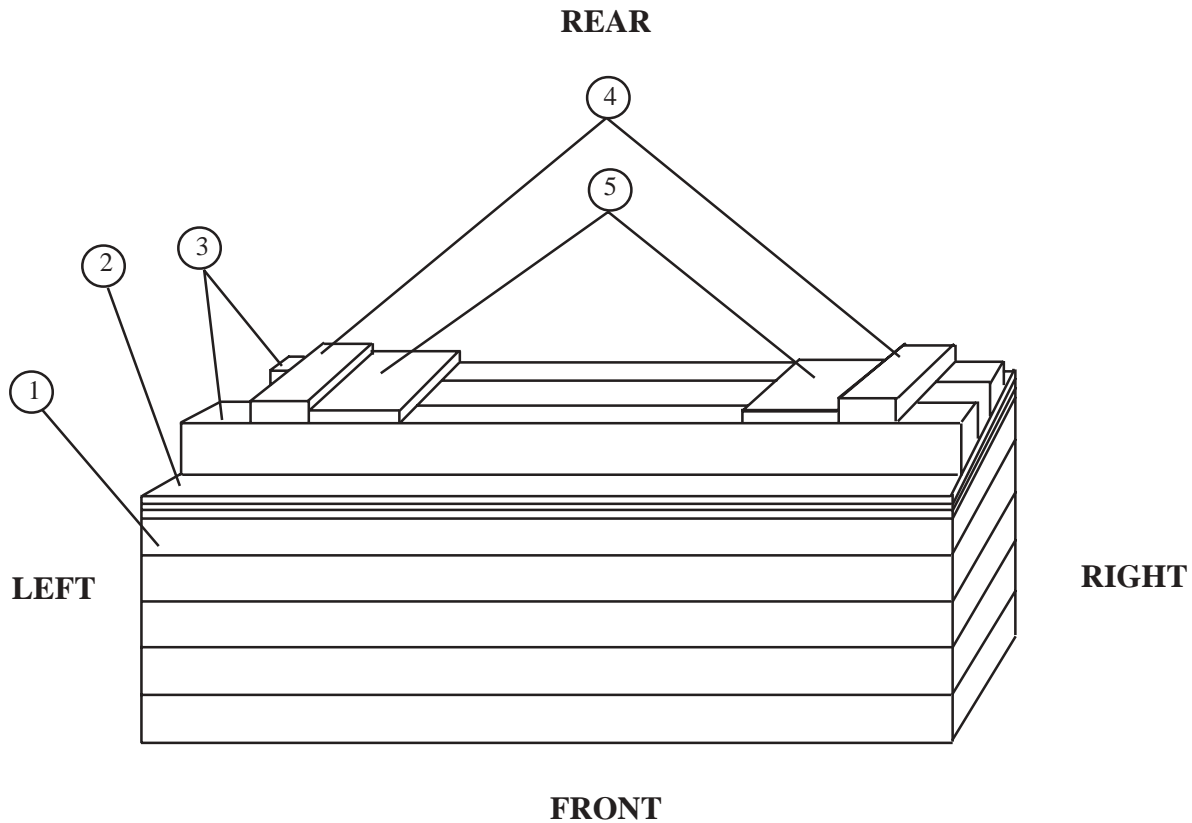

- ① Glue five 48- by 18-inch pieces of honeycomb together to form a base.
- ② Glue and nail three 48- by 18-inch pieces of 3/4-inch plywood together. Glue the plywood to the top of the base.
- ③ Glue and nail two 4- by 4- by 48-inch pieces of lumber on top of the plywood, with one 3 1/2 inches from the front edge of the plywood, and the other 3 1/2 inches from the rear edge of the plywood.
- ④ Glue and nail two 2- by 4- by 11-inch pieces of lumber on top of the 4- by 4- by 48-inch pieces of lumber from step 3. Position one piece 2 inches from the right edges and one piece 2 inches from the left edges of the 4- by 4- by 48-inch pieces of lumber.
- ⑤ Glue and nail two 11- by 6-inch pieces of 3/4-inch plywood on top of the 4- by 4- by 48-inch pieces of lumber in step 3. Position one piece of plywood so that it is flush with the inside edges of the 2- by 4- by 11-inch piece of lumber in step 4. Position the second piece of plywood flush with the inside edges of the left 2- by 4-inch piece of lumber in step 4.

Figure 4-5. Stack 3 prepared

Note: This drawing is not drawn to scale.

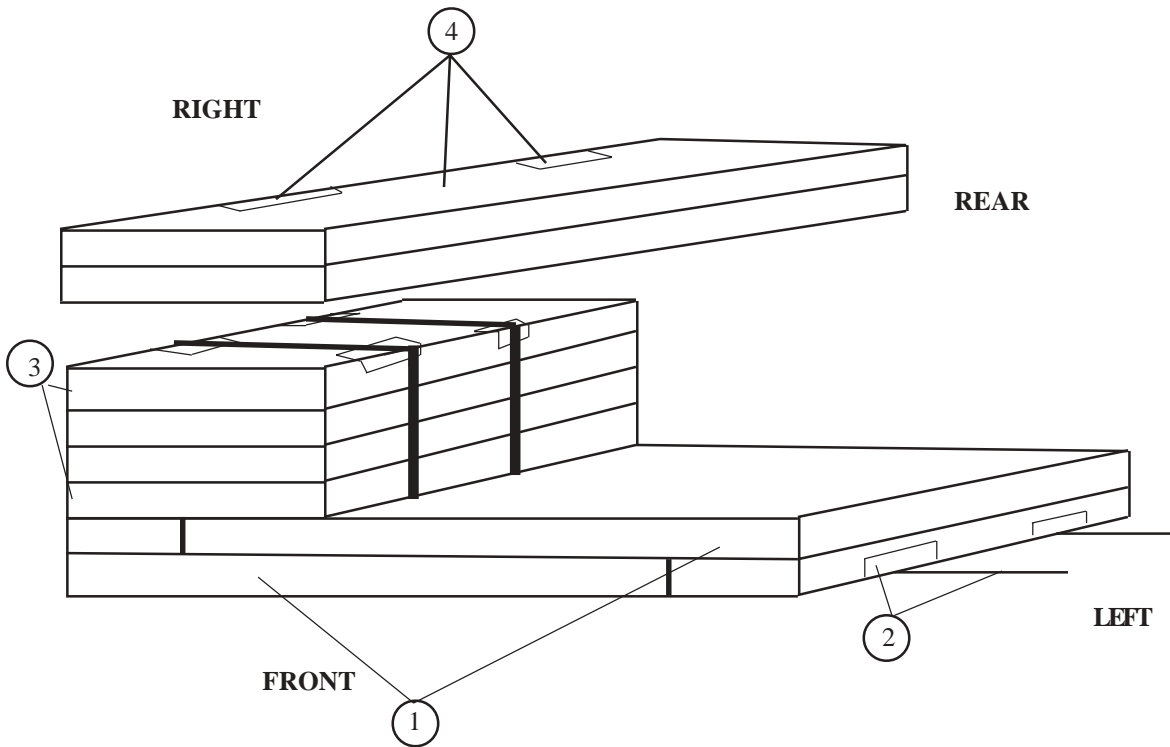

- ① Position a 36- by 44-inch piece of honeycomb beside a 12- by 44-inch piece of honeycomb. Glue a 36- by 44-inch piece of honeycomb and a 12- by 44-inch piece of honeycomb on top of the first layer. Alternate them to form the base.
- ② Place a length of cloth backed tape on the bottom outer edges of the base. Position two 13-foot lengths of type III nylon cord under the base aligned with the strips of tape.
- ③ Form two stacks by gluing four pieces of 18- by 44-inch honeycomb together. Place a sufficient length of cloth backed tape on all edges as shown above. Run a length of 1/2-inch tubular nylon over the strips of tape and around the stack. Secure and tie with a square knot on the outside of the stack. Place the stack flush with the base. **(Do not glue to base.) (The 1/2-inch tubular nylon ties, PULL-OUT AIDS, are to assist in pulling the stacks out from under the vehicle during derigging.)**
- ④ Form two stacks by gluing two pieces of 18- by 44-inch honeycomb together. Place a length of cloth backed tape on each end as shown above. Position one stack on top of the existing four pieces of 18- by 44-inch honeycomb stack in step 3. **(Do not glue.)**

Figure 4-6. Stack 4 prepared

Note: This drawing is not drawn to scale.

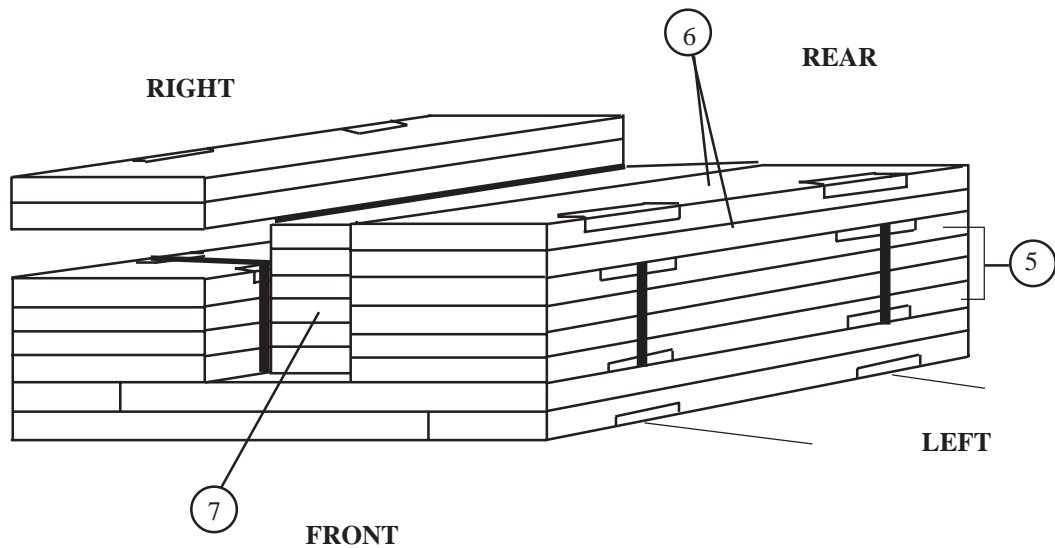

- ⑤ Position the other stack of four pieces of 18- by 44-inch honeycomb flush on top of the base right side.
- ⑥ Position the other stack of two pieces of 18- by 44-inch honeycomb in step 5, flush on top of the four pieces of 18- by 44-inch honeycomb.
- ⑦ Glue six 12- by 36-inch pieces of honeycomb together. Position the stack between the two stacks in step 4 and 5, flush with the rear edge of the base. **(Do not glue to base.)**

Figure 4-6. Stack 4 prepared (Continued)

Note: This drawing is not drawn to scale.

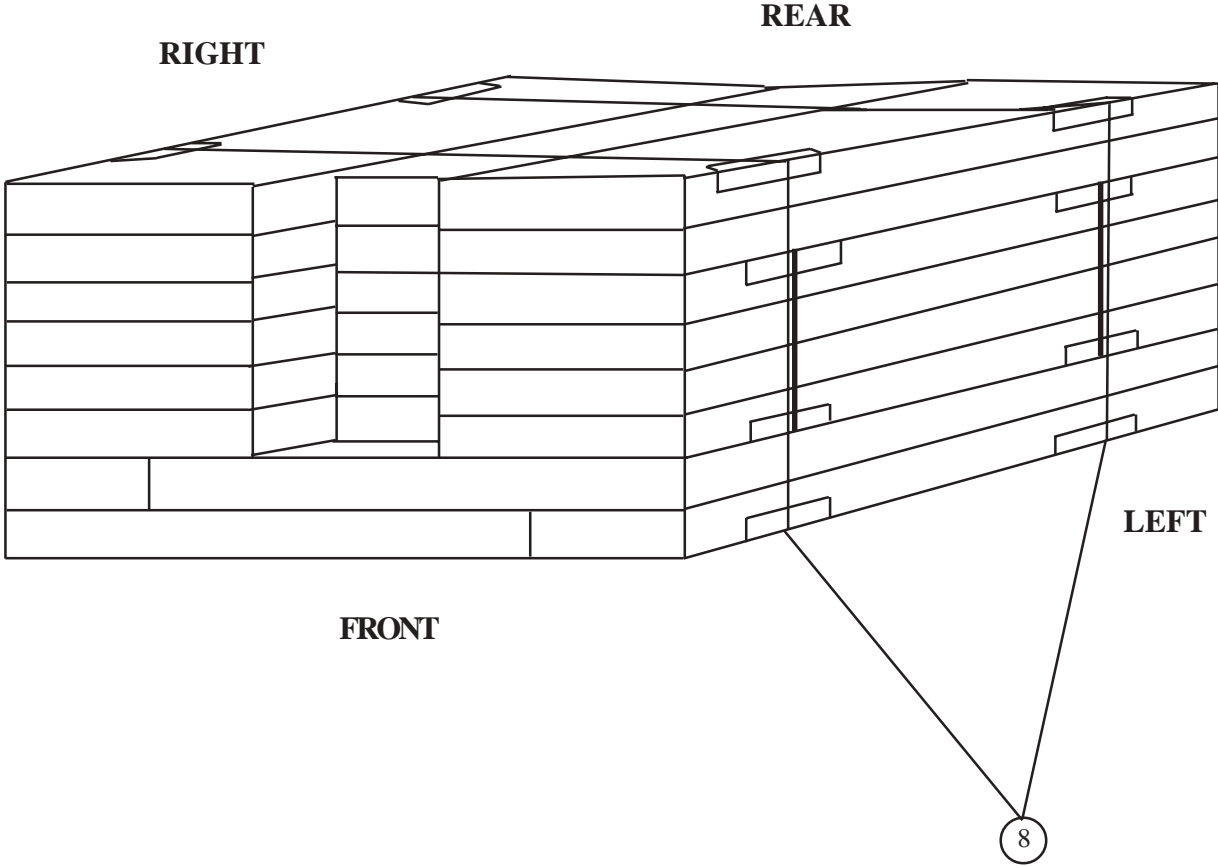

⑧ Secure and tie the type III nylon cord around the completed honeycomb stack.

Figure 4-6. Stack 4 prepared (Continued)

Notes: This drawing is not drawn to scale.
Glue and nail each piece of lumber.

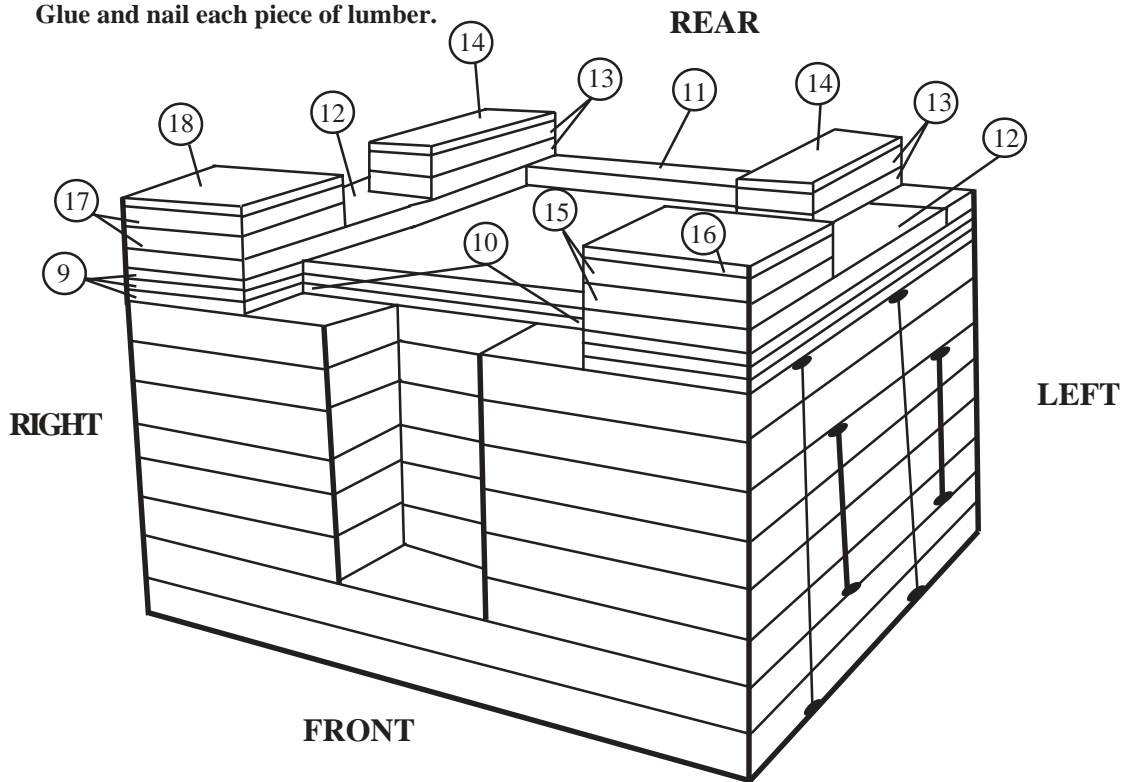

- 9 Glue and nail three 48- by 44-inch pieces of 3/4-inch plywood together. **(Do not build lumber stack on honeycomb stack. The lumber will be placed on the stack later.)**
- 10 Cut a 26-inch long, 7-inch deep cutout in the center of the 48-inch side of the plywood.
- 11 Glue and nail one 2- by 6- by 48-inch piece of lumber flush along the rear edge of the plywood.
- 12 Glue and nail one 2- by 12- by 38 1/2-inch piece of lumber flush with left side and another on the right side of the plywood and the end flush against the 2- by 6- by 48-inch piece of lumber in step 11.
- 13 Glue and nail two 2- by 6- by 21-inch pieces of lumber flush with the right inside edge of the 2- by 12- by 38 1/2-inch lumber and flush with the rear of the 2- by 6- by 48-inch piece of lumber. Glue and nail two pieces flush with the left inside edge of the 2- by 12- by 38 1/2-inch lumber and flush with the rear of the 2- by 6- by 48-inch piece of lumber. **Stack shown is for truck without winch. When truck has a winch, use three 2- by 6- by 21-inch pieces of lumber glued to the outside on the left side instead of two pieces of lumber.**
- 14 Center, glue and nail one 5 1/2- by 21-inch piece of 3/4-inch plywood on top of each of the two pieces of lumber in step 13.
- 15 Glue and nail two 2- by 12- by 12-inch pieces of lumber flush with the left front corner on top of the 2- by 12- by 38 1/2-inch piece of lumber in step 12.
- 16 Center, glue and nail one piece of 11 1/2- by 12-inch piece of 3/4-inch plywood on top of the two pieces of lumber in step 15.
- 17 Glue and nail two 2- by 12- by 12-inch pieces of lumber flush with the right front corner on top of the 2- by 12- by 38 1/2-inch piece of lumber in step 12.
- 18 Center, glue and nail one piece of 11 1/2- by 12-inch piece of 3/4-inch plywood on top of the two pieces of lumber in step 17.
- 19 Glue the completed lumber to the honeycomb base.

Figure 4-6. Stack 4 prepared (Continued)

Note: This drawing is not drawn to scale.

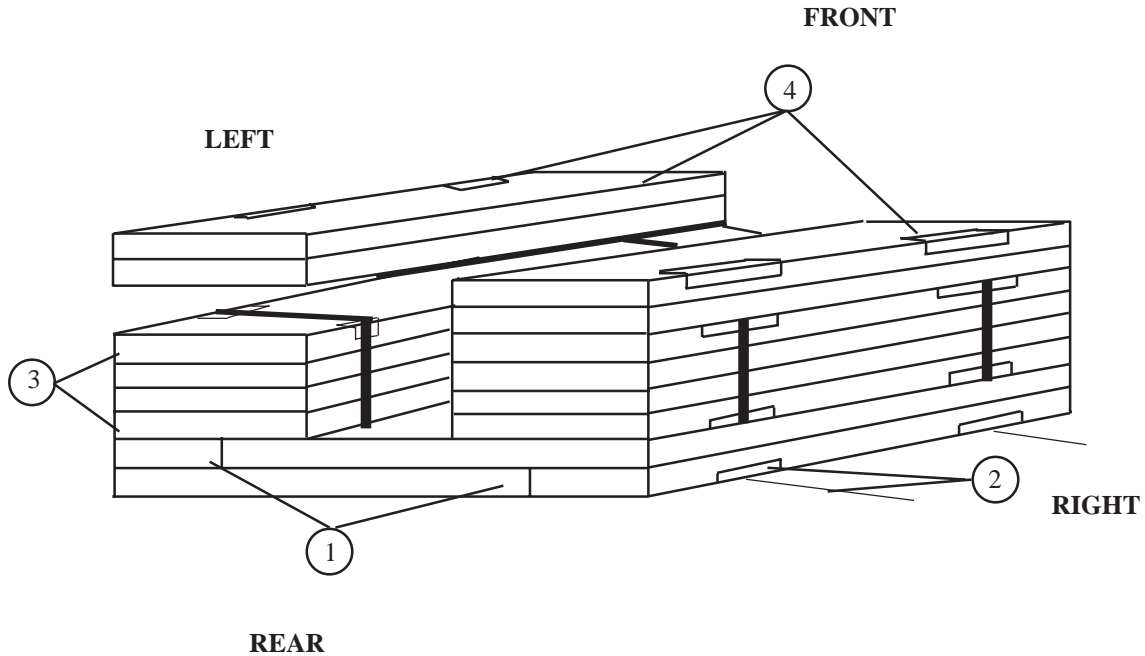

- ① Position a 36- by 46-inch piece of honeycomb beside a 12- by 46-inch piece of honeycomb. Glue a 36- by 46-inch piece of honeycomb and a 12- by 46-inch piece of honeycomb on top of the first layer. Alternate them to form the base.
- ② Place a length of cloth backed tape on the bottom outer edges of the base. Position two 13-foot lengths of type III nylon cord under the base. Align with the strips of tape.
- ③ Form two stacks by gluing four pieces of 18- by 46-inch honeycomb together. Place a sufficient length of cloth backed tape on all edges as shown above. Run a length of 1/2-inch tubular nylon over the strips of tape and around the 18- by 46-inch stacks. Secure and tie with a square knot on the outside of the stack. Place the stack flush with the base. **(Do not glue to base.) (The 1/2-inch tubular nylon ties, PULL-OUT AIDS, are to assist in pulling the stacks out from under the vehicle during derigging.)**
- ④ Form two stacks by gluing two pieces of 18- by 46-inch honeycomb together. Place a length of cloth backed tape on each end. Position each stack on top of the existing stacks. **(Do not glue.)**

Figure 4-7. Stack 5 prepared

Note: This drawing is not drawn to scale.

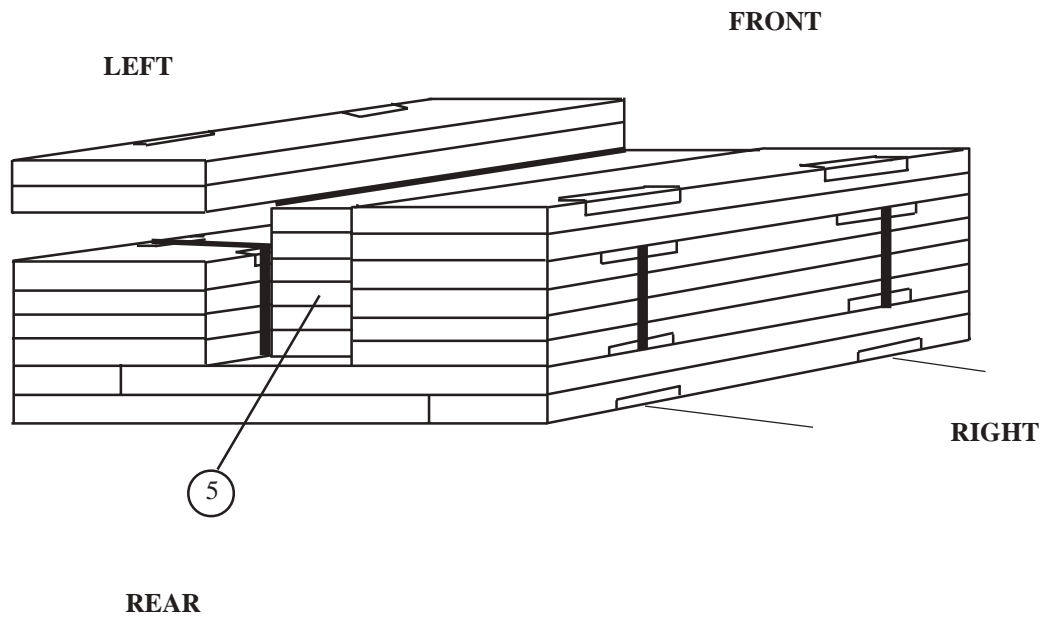

- 5 Form a stack by gluing six 12- by 36-inch pieces of honeycomb together. Position the stack between the two stacks in step 4, flush with the front edge of the base. (**Do not glue to base.**)

Figure 4-7. Stack 5 prepared (Continued)

Note: This drawing is not drawn to scale.

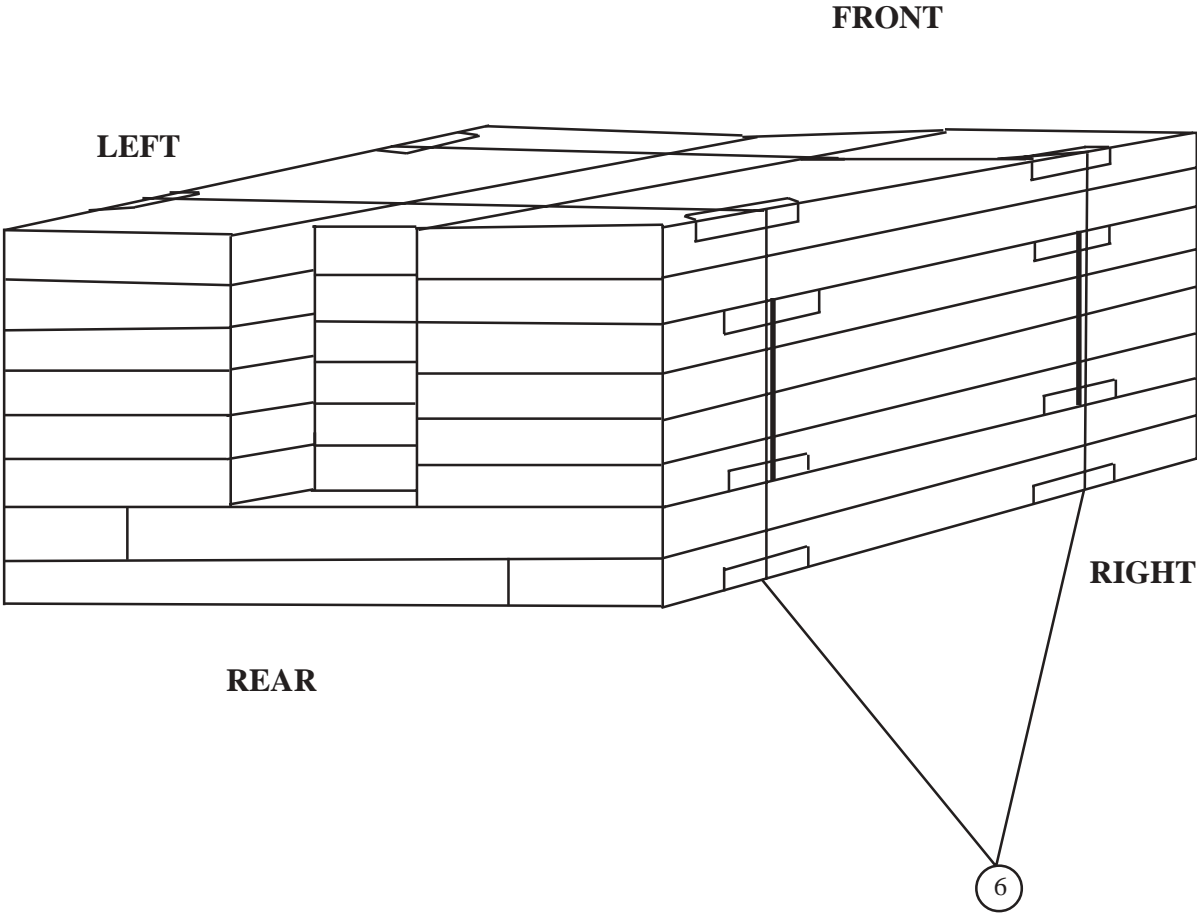

⑥ Secure and tie the type III nylon cord around the completed honeycomb stack.

Figure 4-7. Stack 5 prepared (Continued)

- Notes:** 1. Place the plywood on the honeycomb stack after positioning stack on the platform.
2. This drawing is not drawn to scale.

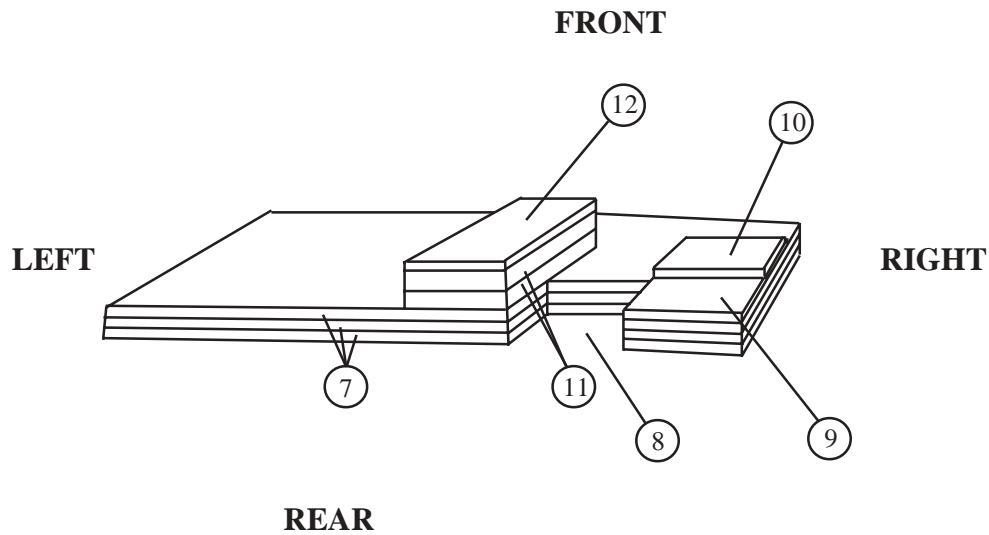

- ⑦ Glue and nail together three 48- by 46-inch pieces of 3/4-inch plywood.
- ⑧ Cut an 8-inch long and 12-inch deep cutout in the rear 48-inch edge of the plywood 8 inches from the right side.
- ⑨ Glue and nail one 8- by 16- by 3/4-inch piece of plywood on top of the plywood flush with the rear and right edges.
- ⑩ Glue and nail one 8- by 6- by 3/4-inch piece of plywood on top of the plywood in step 9 flush with the front and right edges.
- ⑪ Glue and nail two 2- by 8- by 26 1/2-inch pieces of lumber flush with the rear edge of the plywood and even with the left side of the cutout.
- ⑫ Glue and nail one 7 1/2- by 26 1/2-inch piece of 3/4-inch plywood on top of the lumber in step 11 flush with the front edge of the lumber.

Figure 4-7. Stack 5 prepared (Continued)

Note: This drawing is not drawn to scale.

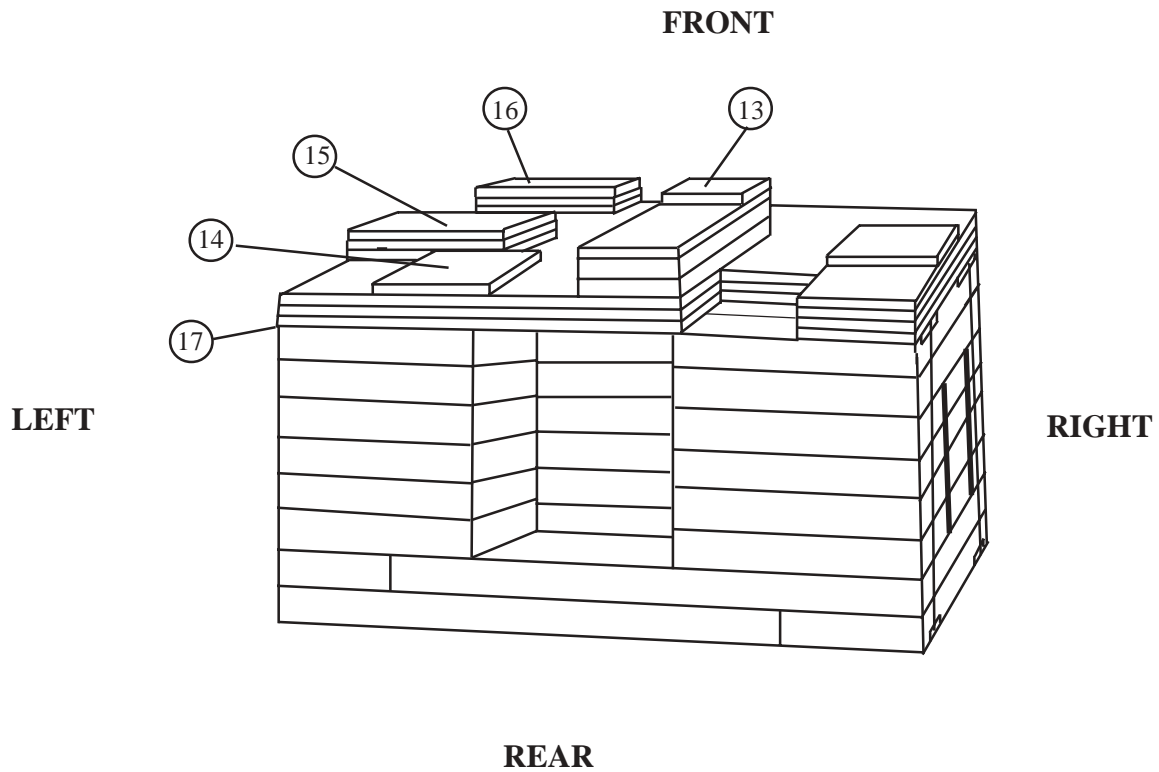

- ⑬ Glue and nail one 7 1/2- by 8-inch piece of 3/4-inch plywood on top of the plywood in step 12 flush with the front edge of the lumber.
- ⑭ Glue and nail one 10- by 10-inch piece of 3/4-inch plywood on top of the plywood flush with the rear edge and 8 inches from the left edge.
- ⑮ Glue and nail three 14- by 12-inch pieces of 3/4-inch plywood on top of the plywood 12-inch side flush against the left edge and flush against the front edge of the plywood in step 14.
- ⑯ Glue and nail three 14- by 12-inch pieces of 3/4-inch plywood on top of the plywood 12-inch side flush with the left front corner.
- ⑰ Glue the completed lumber to the honeycomb base.

Figure 4-7. Stack 5 prepared (Continued)

Note: This drawing is not drawn to scale.

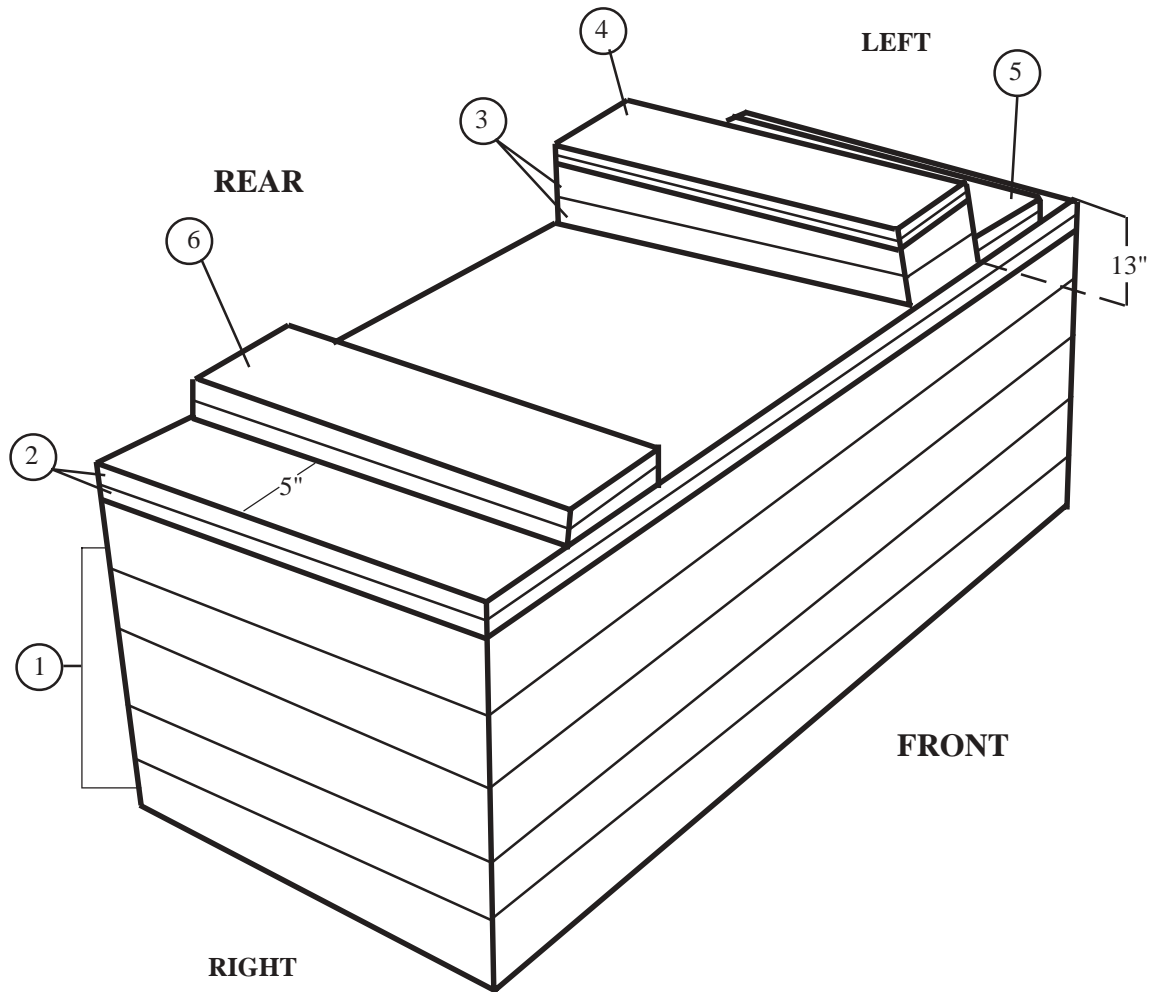

- ① Glue five 48- by 18-inch pieces of honeycomb together to form a base.
- ② Glue, center and nail two 48- by 18-inch pieces of 3/4-inch plywood on top of base.
- ③ Glue and nail one stack of two 2- by 6- by 18-inch pieces of lumber 13 inches from the left edge of the stack base.
- ④ Form three stacks of two 18- by 5 1/2-inch pieces of plywood. Glue and nail one stack on top of lumber installed in step 3.
- ⑤ Glue and nail another stack 5 inches from the left side.
- ⑥ Glue and nail the remaining stack 5 inches from the right side.

Figure 4-8. Stack 6 prepared

Note: This drawing is not drawn to scale.

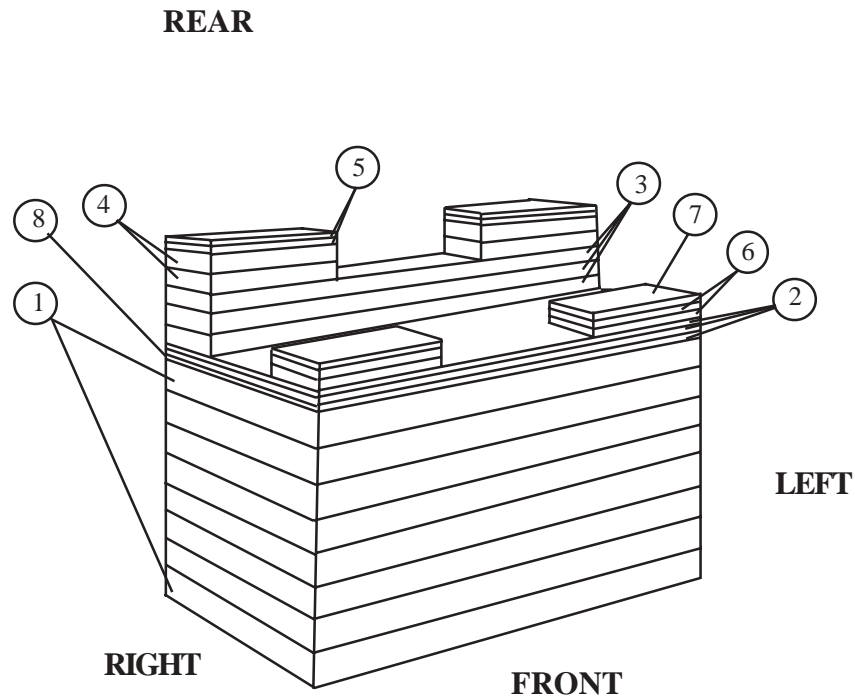

- ① Glue eight 43- by 24-inch pieces of honeycomb together to form a base.
- ② Glue and nail three 43- by 24-inch pieces of 3/4-inch plywood together.
- ③ Glue and nail three 2- by 8- by 43-inch pieces of lumber. Center, glue and nail each piece of lumber flush with the rear edge of the plywood.
- ④ Glue and nail two 2 piece stacks of 2- by 8- by 12-inch lumber. Glue and nail one stack flush with the right edge and one stack flush with left edge of the lumber in step 3.
- ⑤ Glue two 2 piece stacks of 7 1/2- by 12-inch pieces of 3/4-inch plywood. Glue and nail one stack on top of the right and left stacks of lumber in step 4.
- ⑥ Glue two 2 piece stacks of 14- by 7-inch pieces of 3/4-inch plywood. Glue and nail each 14-inch sided stack flush, with the right and left front corners.
- ⑦ Glue and nail one 14- by 7-inch piece of 1/2-inch plywood on top of the 14- by 7-inch pieces of 3/4-inch plywood
- ⑧ Glue the completed lumber to the honeycomb base.

Figure 4-9. Stack 7 prepared

Note: This drawing is not drawn to scale.

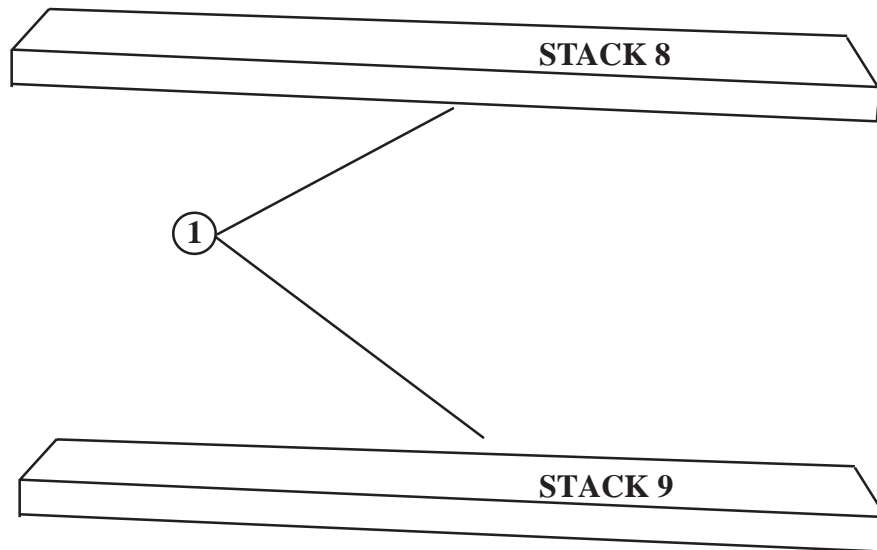

① Cut two 18- by 96-inch pieces of honeycomb.

Figure 4-10. Stacks 8 and 9 prepared

Note: This drawing is not drawn to scale.

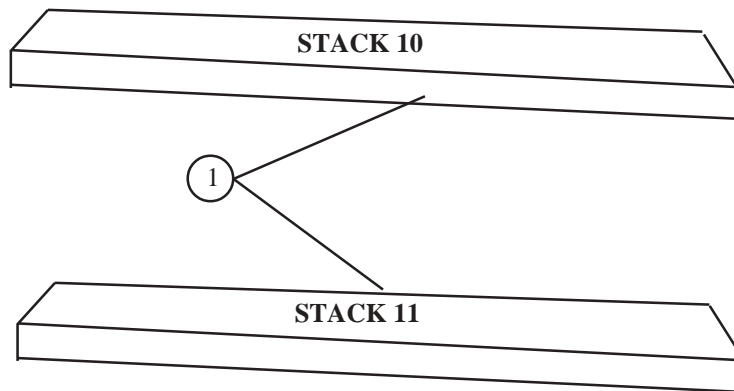

- ① Cut two 18- by 74-inch pieces of honeycomb.

Figure 4-11. Stacks 10 and 11 prepared

4-4. Positioning Honeycomb Stacks

Position the honeycomb stacks as shown in Figure 4-12.

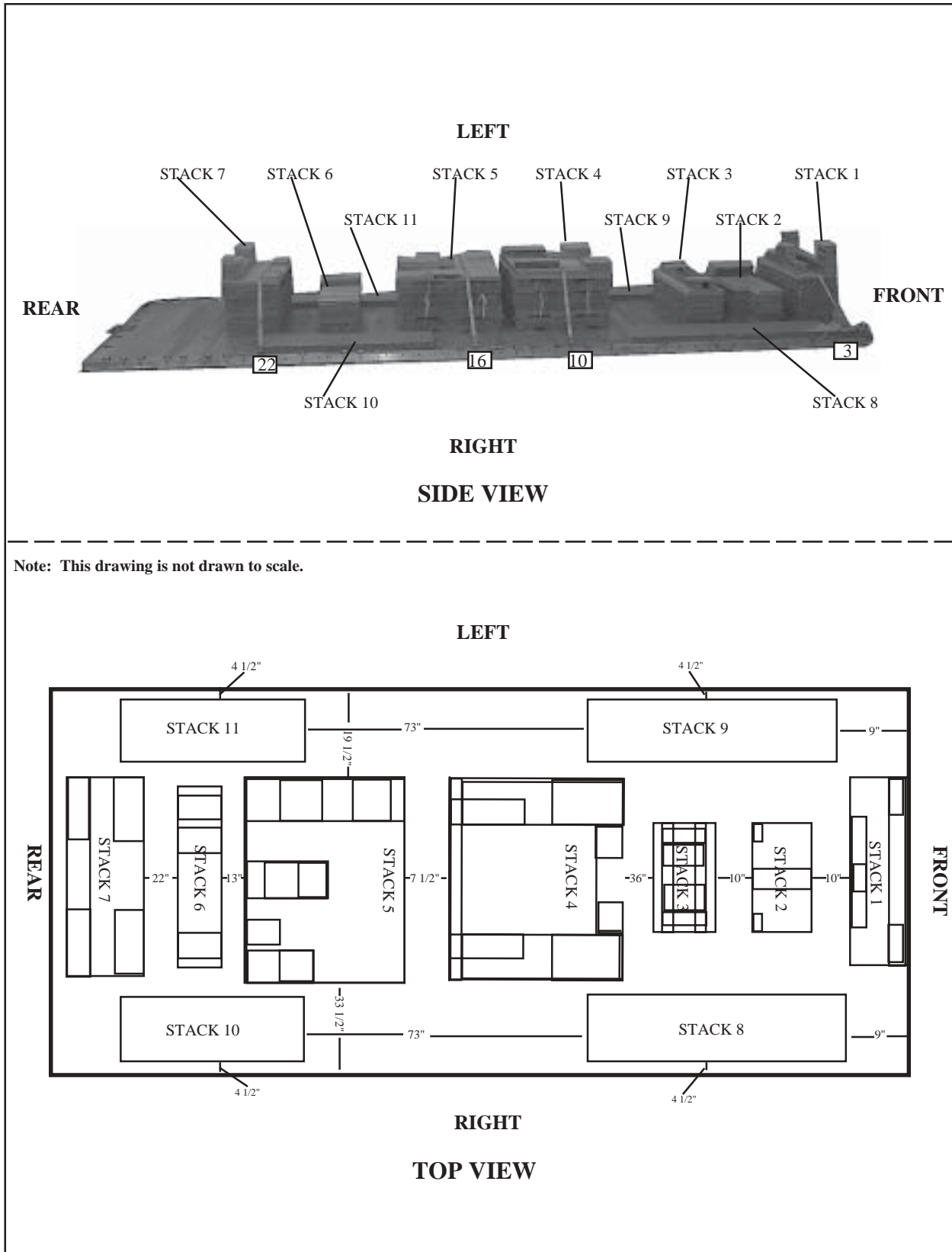

Figure 4-12. Honeycomb stacks positioned on platform

Stack Number	Instructions
1	Position stack 1, centered and flush with the front edge of the platform. Secure the stack by passing a 15-foot tiedown lashing through clevis 3 and through its own D-ring. Route the lashing over the stack and attach it to clevis 3A with a D-ring and loadbinder.
2	Position stack 2, centered and 10 inches from stack 1.
3	Position stack 3, centered and 10 inches from stack 2.
4	Position stack 4, centered and 36 inches from stack 3. Secure the stack by passing a 15-foot tiedown lashing through clevis 10 and through its own D-ring. Route the lashing over the stack and attach it to clevis 10A with a D-ring and a loadbinder.
5	Position stack 5, 33 1/2 inches from the right side rail and 7 1/2 inches from stack 4. Secure the stack by passing a 15-foot tiedown lashing through clevis 16 and through its own D-ring. Route it over the stack and attach it to clevis 16A with a D-ring and a loadbinder.
6	Position stack 6, centered and 13 inches from stack 5.
7	Position stack 7, centered 22 inches from stack 6. Secure the stack by passing a 15-foot tiedown lashing through clevis 22 and through its own D-ring. Route it over the stack and attach it to clevis 22A with a D-ring and a loadbinder.
8	Position stack 8, 9 inches from the front edge of the platform and 4 1/2 inches from the right platform side rail.
9	Position stack 9, 9 inches from the front edge of the platform and 4 1/2 inches from the left platform side rail.
10	Position stack 10, 73 inches from stack 8 and 4 1/2 inches from the right platform side rail.
11	Position stack 11, 73 inches from stack 9 and 4 1/2 inches from the left platform side rail.

Figure 4-12. Honeycomb stacks positioned on platform (Continued)

4-5. Preparing Truck

Prepare the M1094 dump truck as shown in *Figure 4-13* and as described below.

- a. Make sure the fuel tank is not more than 3/4 full.
- b. Make sure the batteries and compartment comply with AFMAN(I) 24-204/TM 38-250.

NOTE: If the dump truck has wooden sideboards installed on the truck bed sidewalls, they must be removed for Low-Velocity Airdrop.

- c. Remove radio mount if equipped and secure in cab storage box, padded with cellulose wadding and the remaining space filled with honeycomb to prevent movement.

The following is a list of materials used for truck preparation.

PIECES	WIDTH (inches)	LENGTH (inches)	MATERIAL
1	36	80	Honeycomb
2	18	60	Honeycomb
10	2- by 6	13 1/2	Lumber
2	4- by 4	6	Lumber
4	2- by 4	15	Lumber
4	2- by 4	6	Lumber
1	10	10	3/4-inch Plywood
2	2- by 6	6	Lumber
1	36	96	Honeycomb
1	4	6	Honeycomb
4	1/2	10	Bolts (washers and nuts)
1	13	82	3/4-inch Plywood
1	13	82	Honeycomb

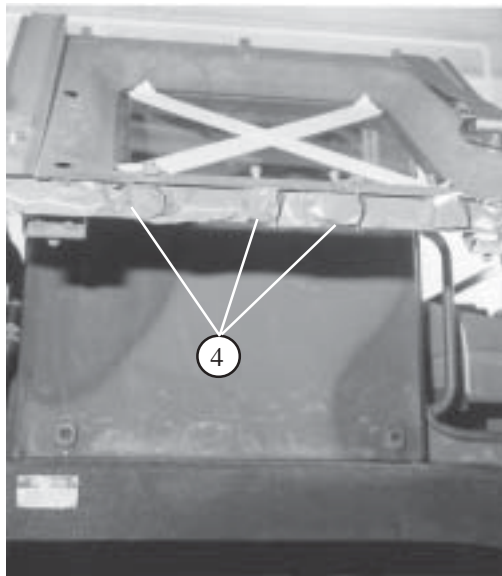
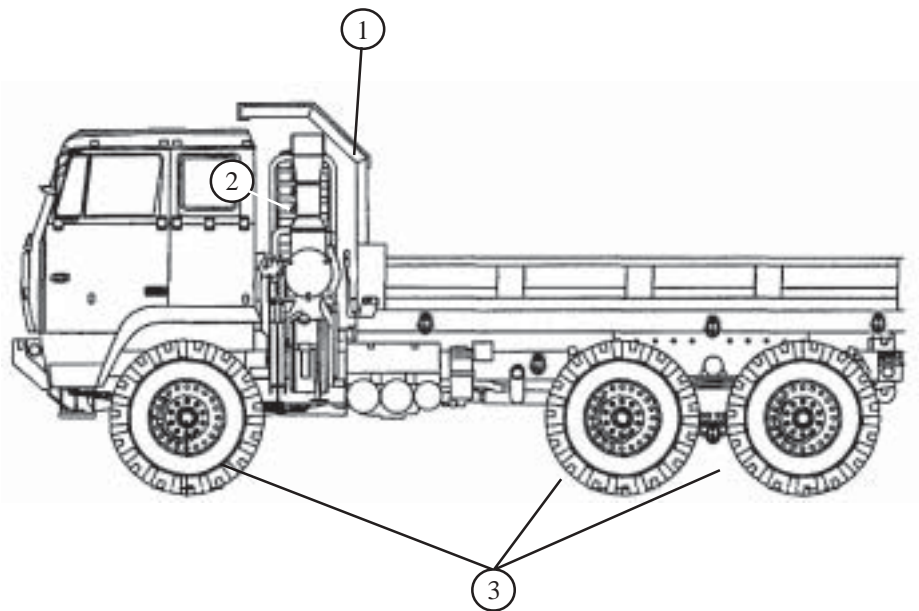

- ① Unpin the cab protector, rotate it into the truck bed and reinsert the pin.
- ② Remove the air intake and any external radio mounts on the cab.
- ③ Deflate all tires to sand mode (22 PSI), allowing the vehicle to sit on the honeycomb stacks correctly. **Note: Verify each individual tire pressure for accuracy.**
- ④ Remove the roof and secure the roof bolts with tape.

Figure 4-13. Truck prepared

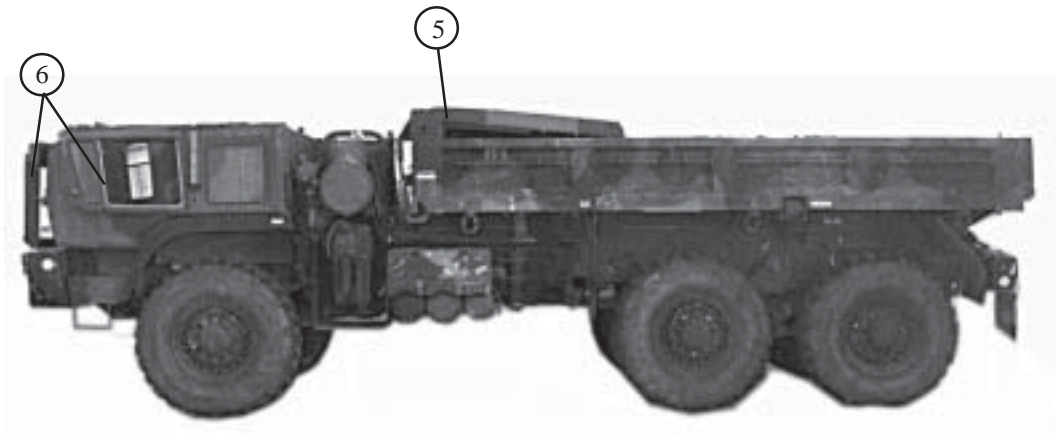
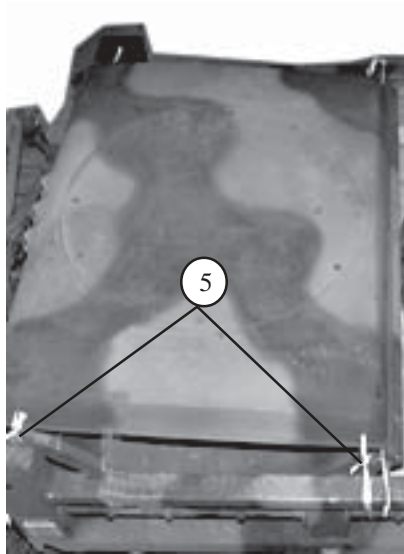

- ⑤ Place the roof on the cab protector in the truck bed with lights facing forward. Secure corners with 1/2-inch tubular nylon.

Note: The cab protector, roof and spare tire will be stowed with the accompanying load.

- ⑥ Remove windshield wipers, fold windshield down. Roll windows down and fold down side window frames.

Figure 4-13. Truck prepared (Continued)

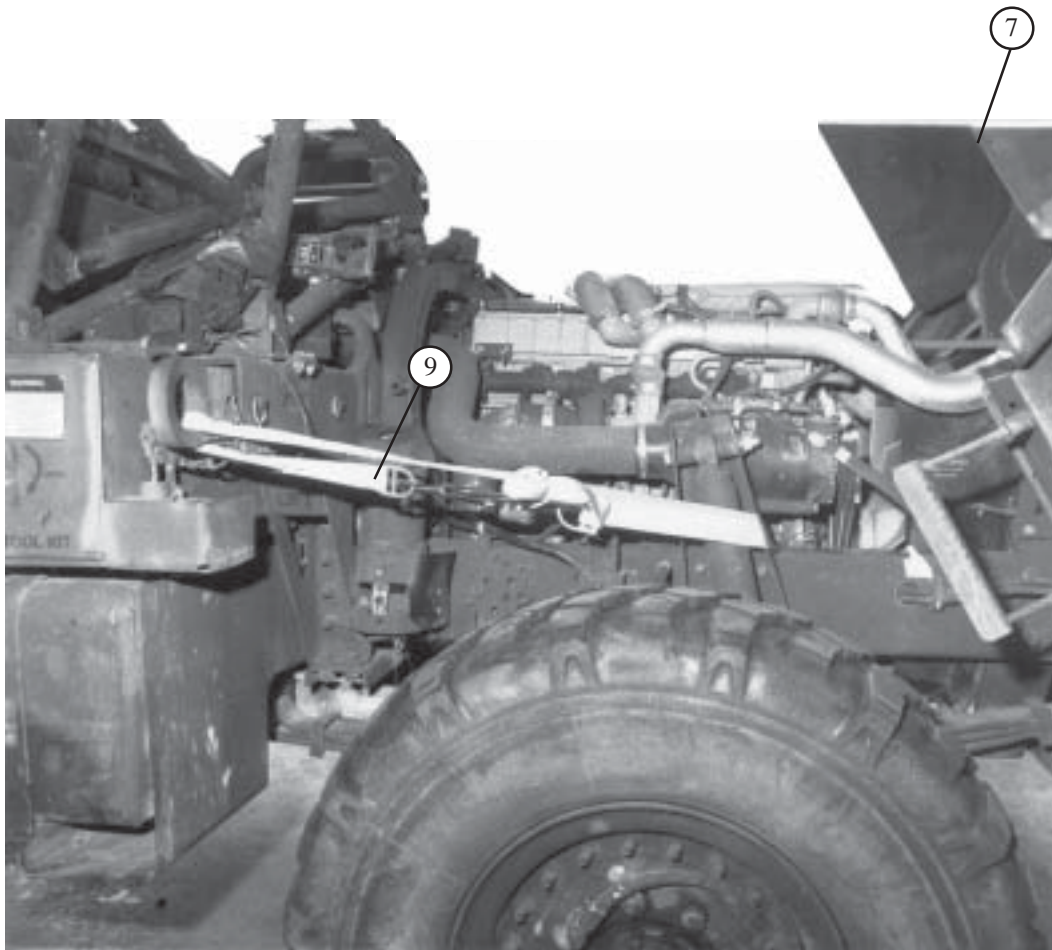

- ⑦ Place the cab compartment in the raised position.
- ⑧ Tape the spare tire strap to the spare tire carrier. (Not shown).
- ⑨ Install motor mount support by routing a 15-foot tiedown lashing through the right side lifting point, in front of the shock absorber, over the frame, behind/under the motor mount, back over the frame, back in front of the shock absorber, and back to the lifting point. Secure the lashing with a D-ring and loadbinder. (Ensure lashing runs underneath all hoses and wiring). Repeat for the left side.

Figure 4-13. Truck prepared (Continued)

Note: This drawing is not drawn to scale.

REAR MOTOR SUPPORT REAR VIEW

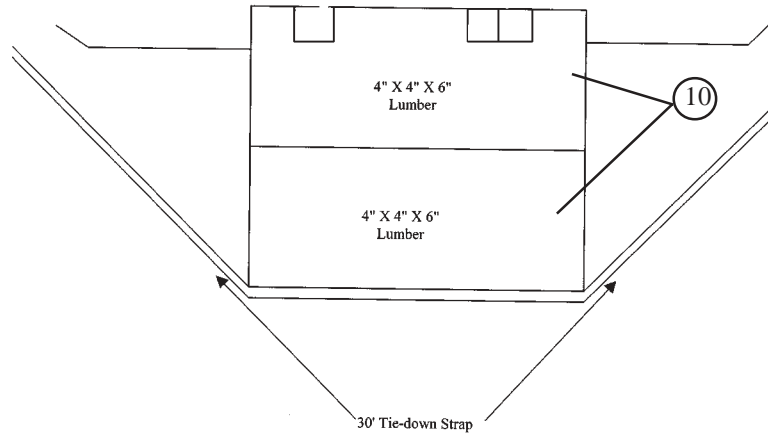

REAR MOTOR SUPPORT TOP VIEW

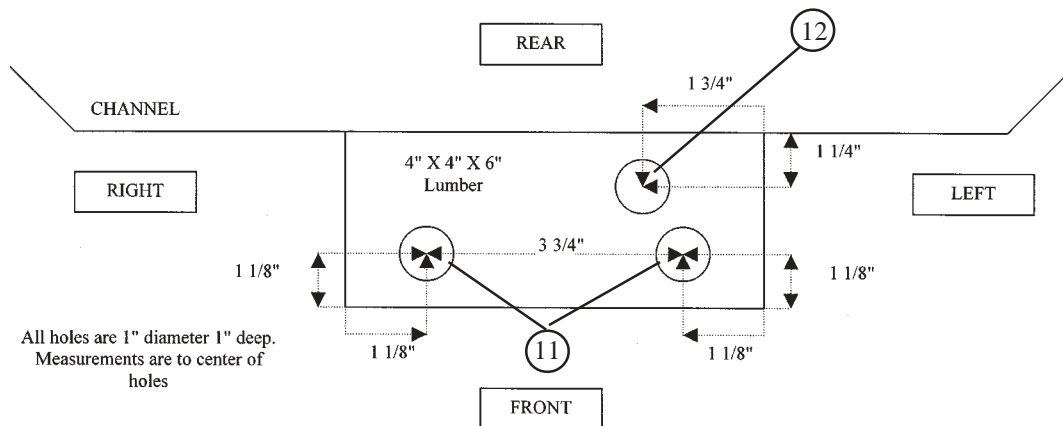

- ⑩ Install rear motor support by cutting two 4- by 4- by 6-inch pieces of lumber.
- ⑪ Countersink three holes 1-inch in diameter, 1-inch deep. Drill one hole 1 1/8 inch from the left and front edge. Drill another hole 1 1/8 inch from the right and front edge. Ensure there are 3 3/4 inches between the first two holes.
- ⑫ Drill the last hole 1 1/4 inch from the rear edge and 1 3/4 inch from the left edge in one piece of 4- by 4- by 6-inch lumber. Place the other 4- by 4- by 6-inch piece of lumber under the first piece of lumber and tape them together with cloth-backed tape leaving the holes exposed. Place the countersunk holes of the 4- by 4- by 6-inch piece of lumber over the bolts in the bell housing.

Figure 4-13. Truck prepared (Continued)

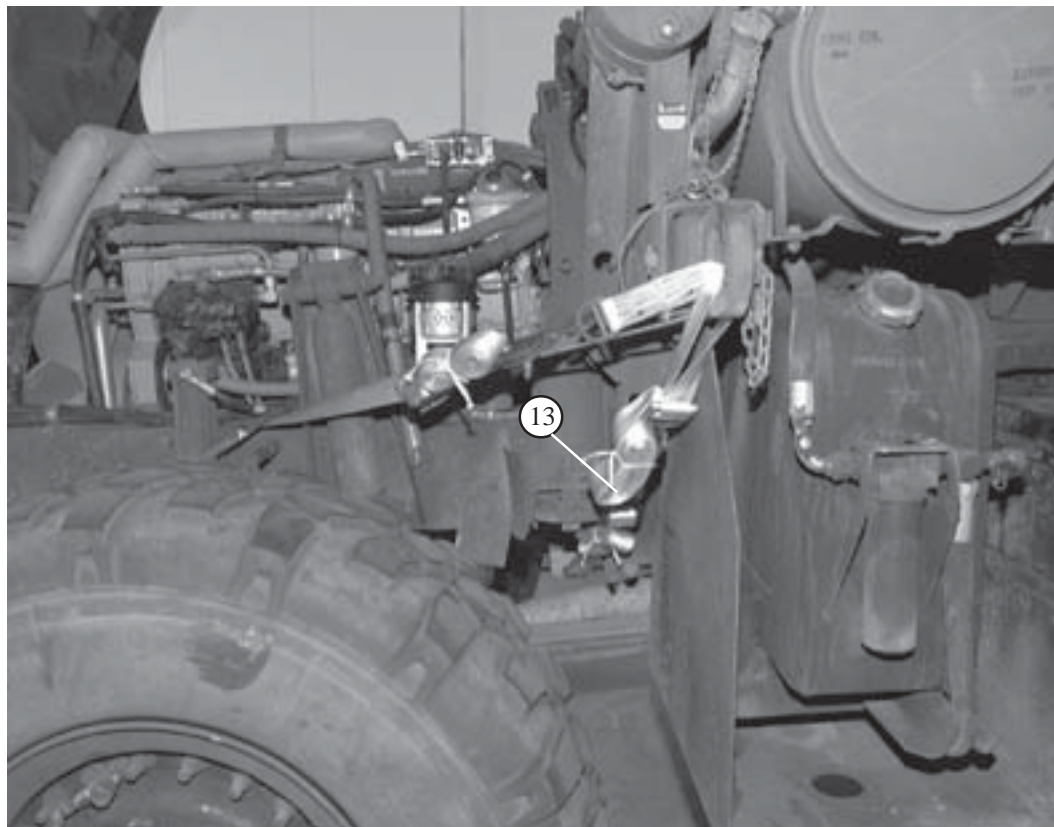
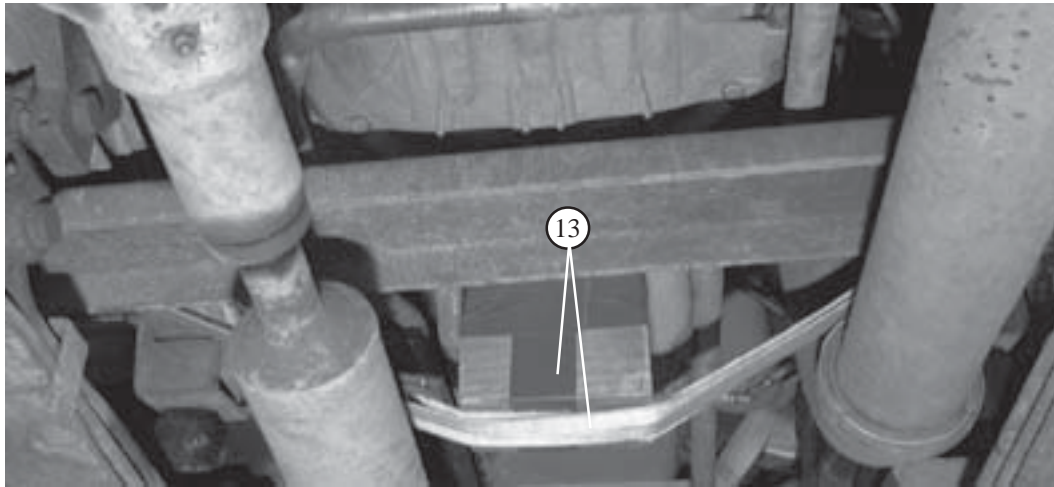

- ⑬ Install front motor support by routing a 30-foot lashing through the right side lifting point under the 4- by 4- by 6-inch piece of lumber and through the left side lifting point, and back under the 4- by 4- by 6-inch piece of lumber. Secure with a D-ring and loadbinder.

Figure 4-13. Truck prepared (Continued)

Note: This drawing is not drawn to scale.

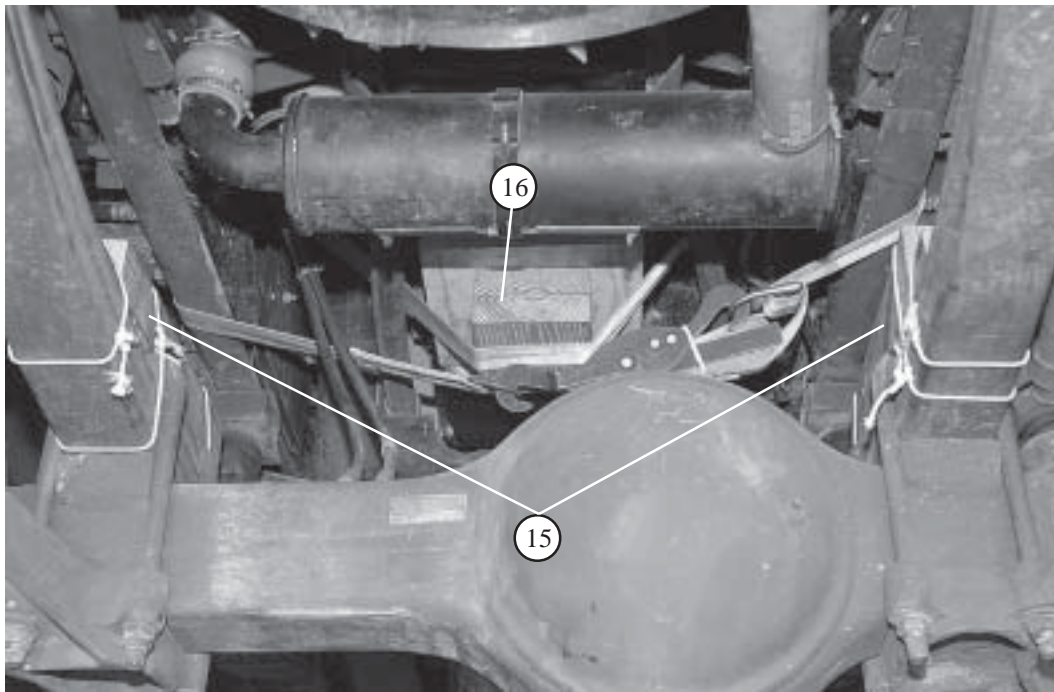
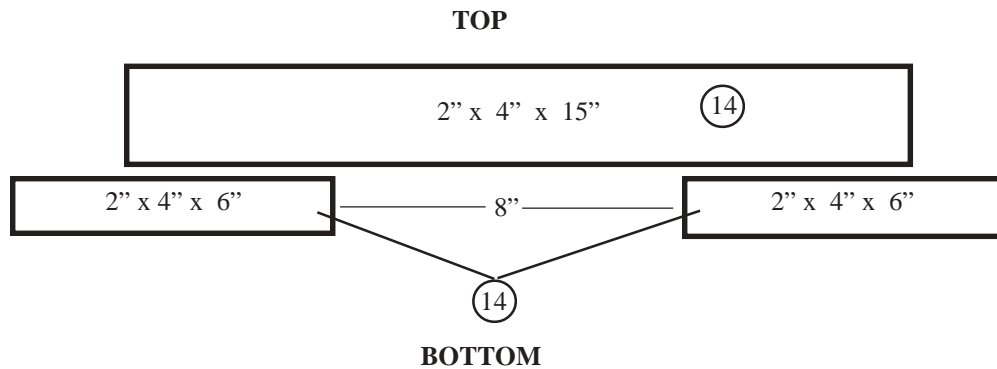

- (14) Glue and nail two 2- by 4- by 15-inch pieces of lumber on the 2 inch side of the two 2- by 4- by 6-inch pieces of lumber on the 4 inch side and 8 inches apart from each other.
- (15) Position lumber from step 14 on top of the right and left leaf springs above the intermediate (middle) driving axle and secure with type III nylon cord.
- (16) Nail together two 2- by 6- by 6-inch pieces of lumber. Center and glue a 10- by 10- by 3/4-inch piece of plywood to the two 2- by 6- by 6-inch pieces of lumber. Position against the oil pan and front of the engine.

Note: Ensure the placement is as far forward as possible.

Figure 4-13. Truck prepared (Continued)

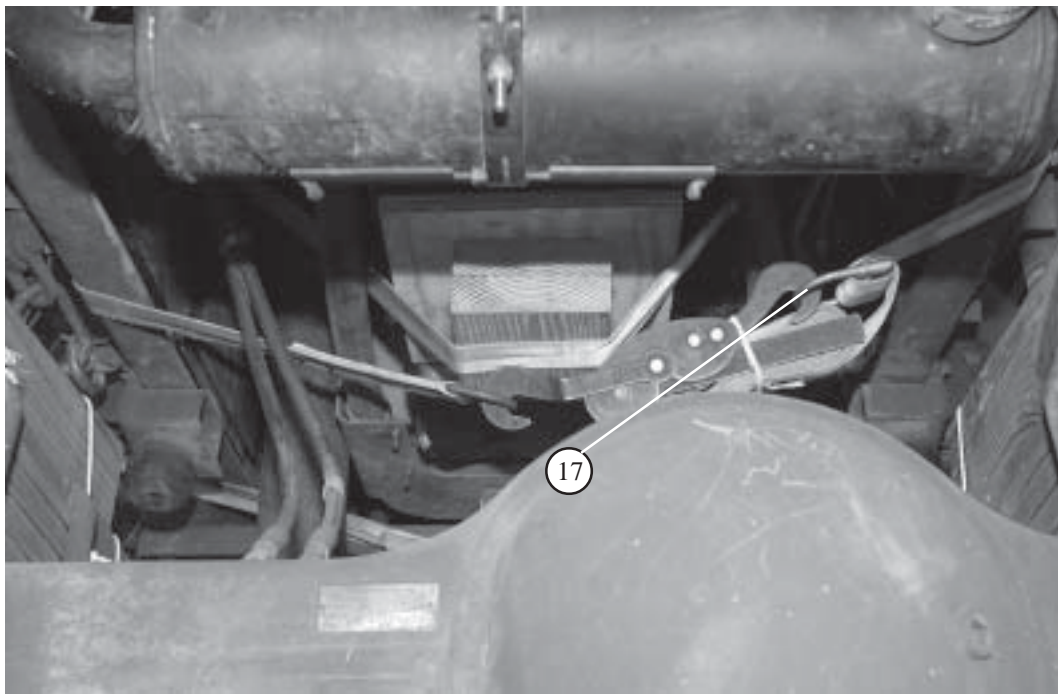
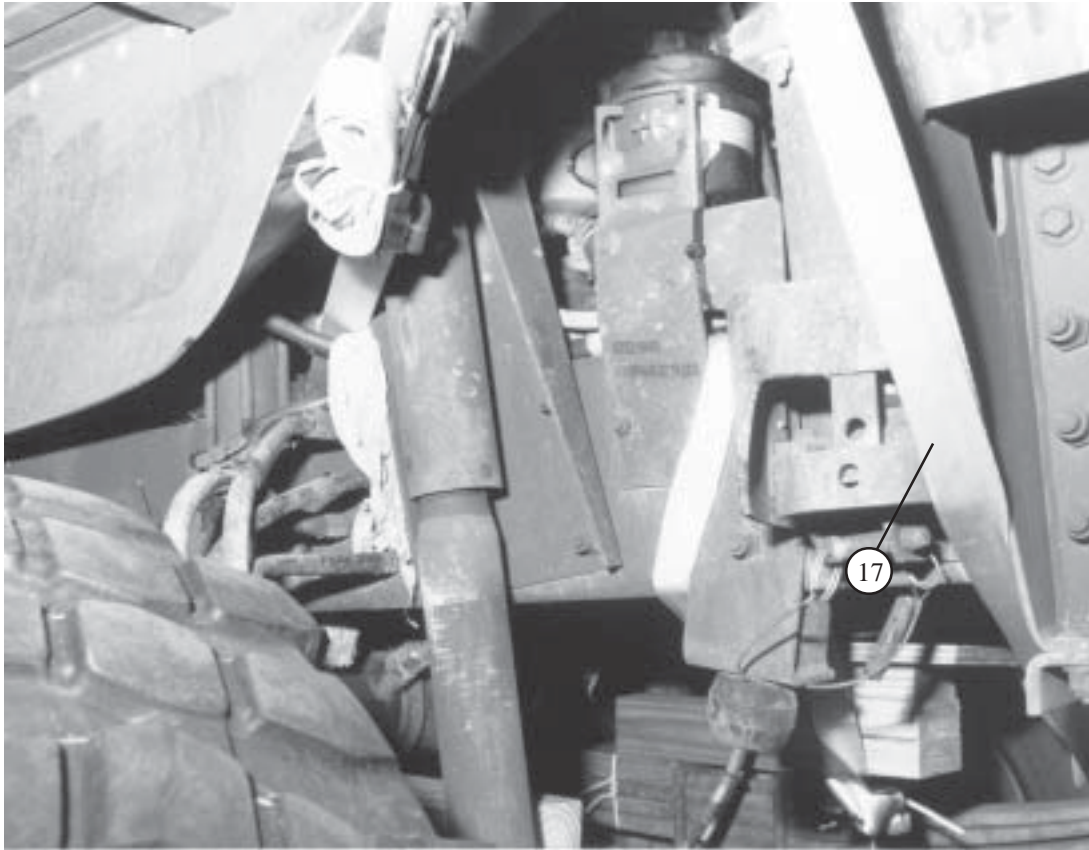

- ①7 Install a front engine support by routing a 15-foot lashing in rear of motor mounts around the left and right main frames (under all hoses). Secure the lumber and plywood with D-ring and loadbinder.

Figure 4-13. Truck prepared (Continued)

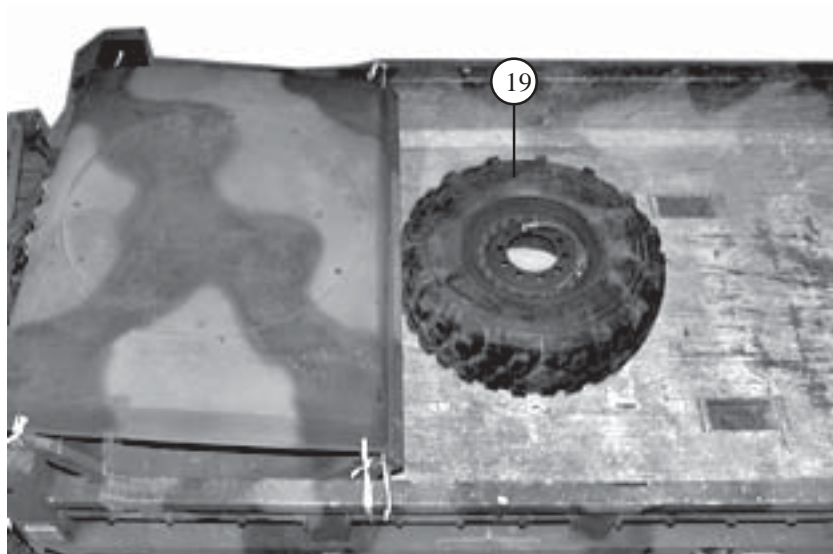
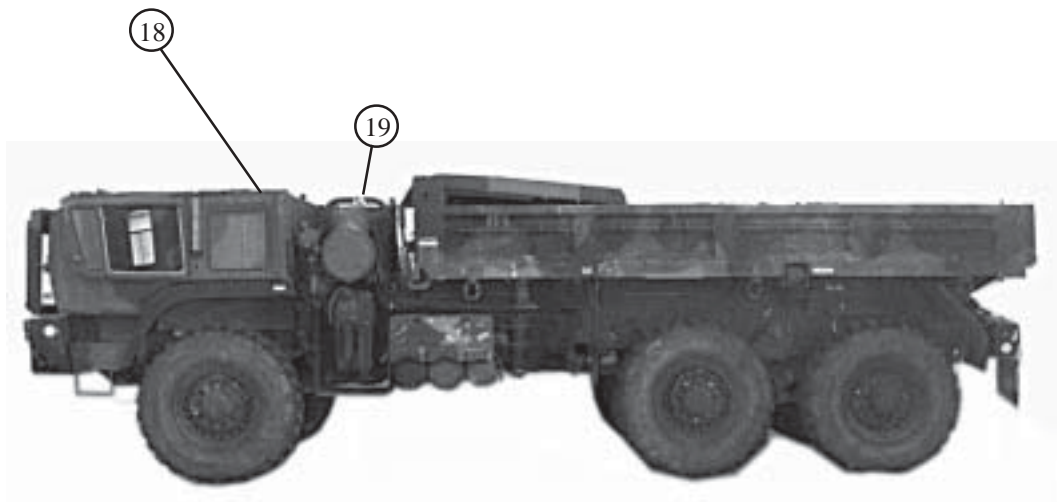

- ⑱ Place the cab compartment in the lowered position.
- ⑲ Remove the spare tire from the rack and place it in the bed behind the cab protector and roof. Leave the spare tire carrier down.

Figure 4-13. Truck prepared (Continued)

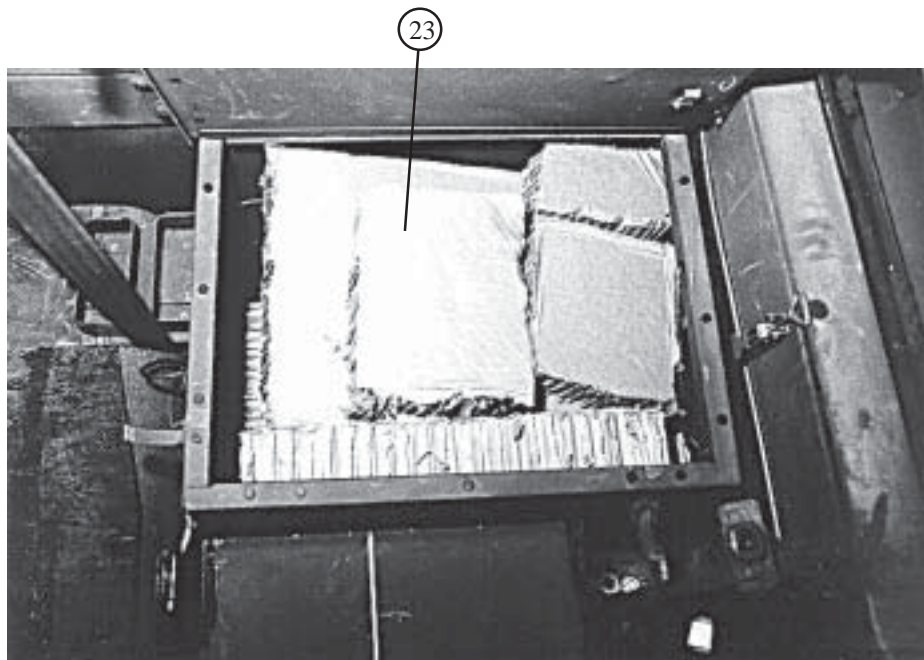
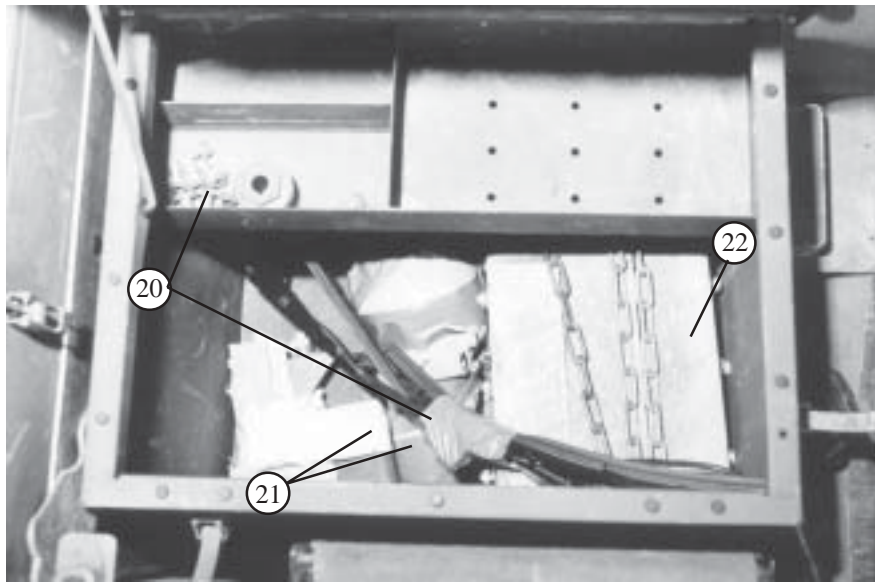

- ②① Stow the windshield wipers blades and bolts in the passenger storage box.
- ②① Remove the sun-visors and stow in the passenger storage box.
- ②② Secure the chock blocks in the storage box in the cab.
- ②③ Fill the driver and passenger storage boxes with honeycomb. Secure the lid with type III nylon cord.

Figure 4-13. Truck prepared (Continued)

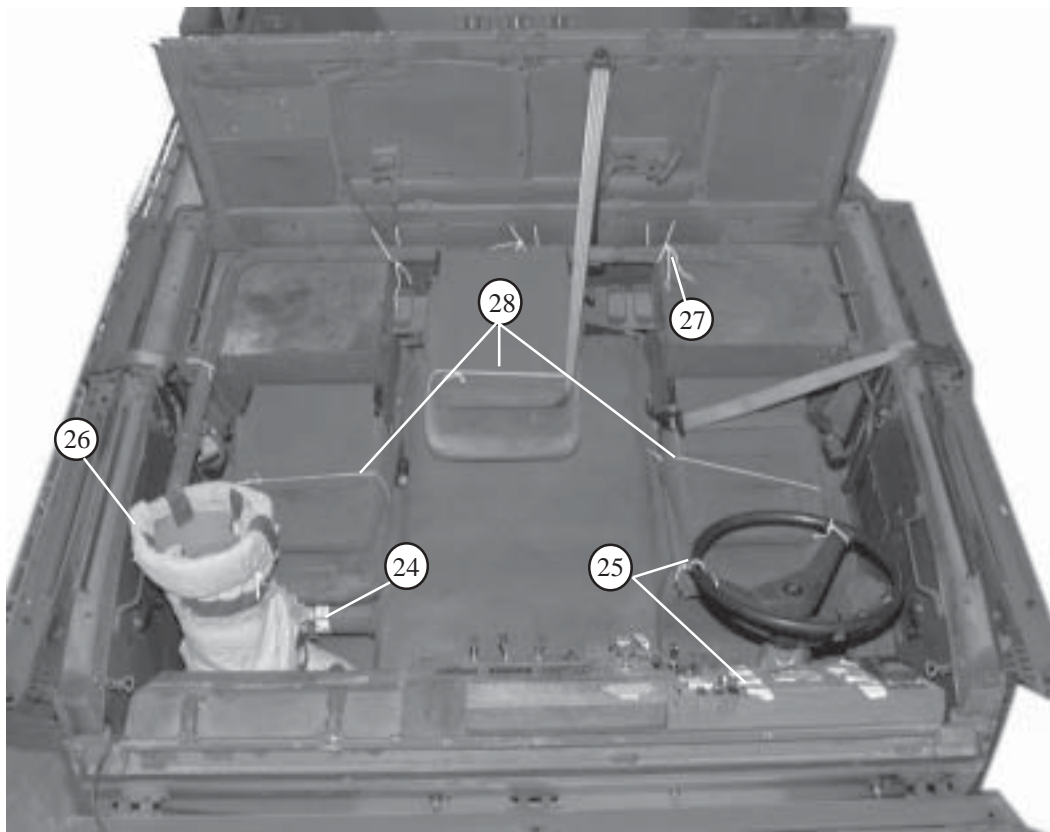

- ②④ Secure the fire extinguisher with type III nylon cord.
- ②⑤ Secure the steering wheel and hand throttle with type III nylon cord and tape all gauges.
- ②⑥ Wrap the air intake stack with cellulose wadding, stow and secure with type III nylon cord in the cab.
- ②⑦ Remove the davit. Secure in four places with type III nylon cord in the cab. (It is attached to the back of cab.)
- ②⑧ Lower the seats and secure with type III nylon cord.

Figure 4-13. Truck prepared (Continued)

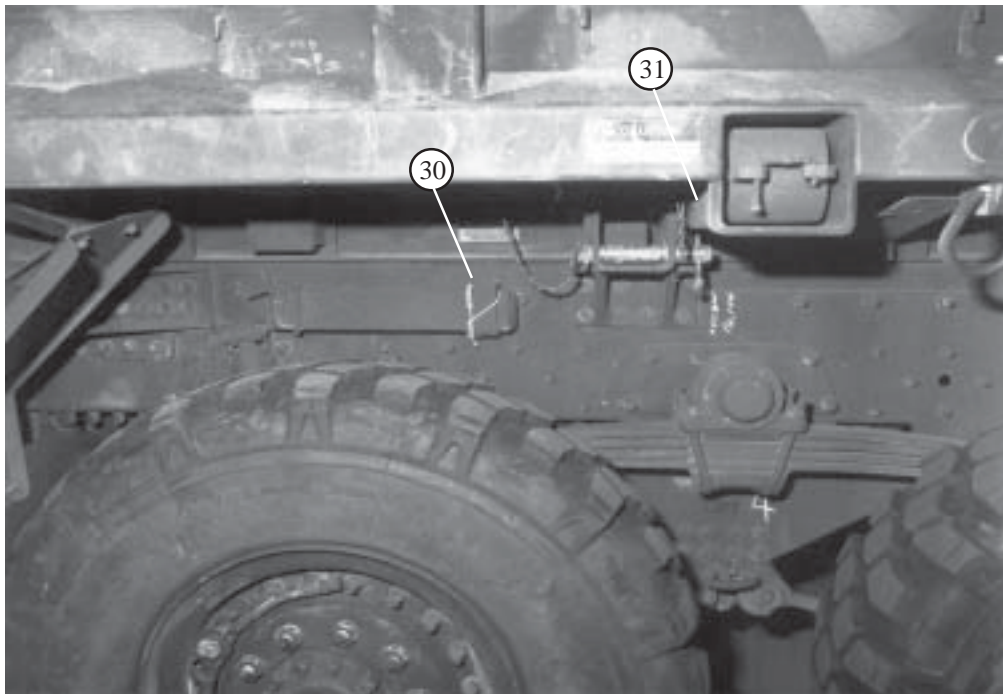
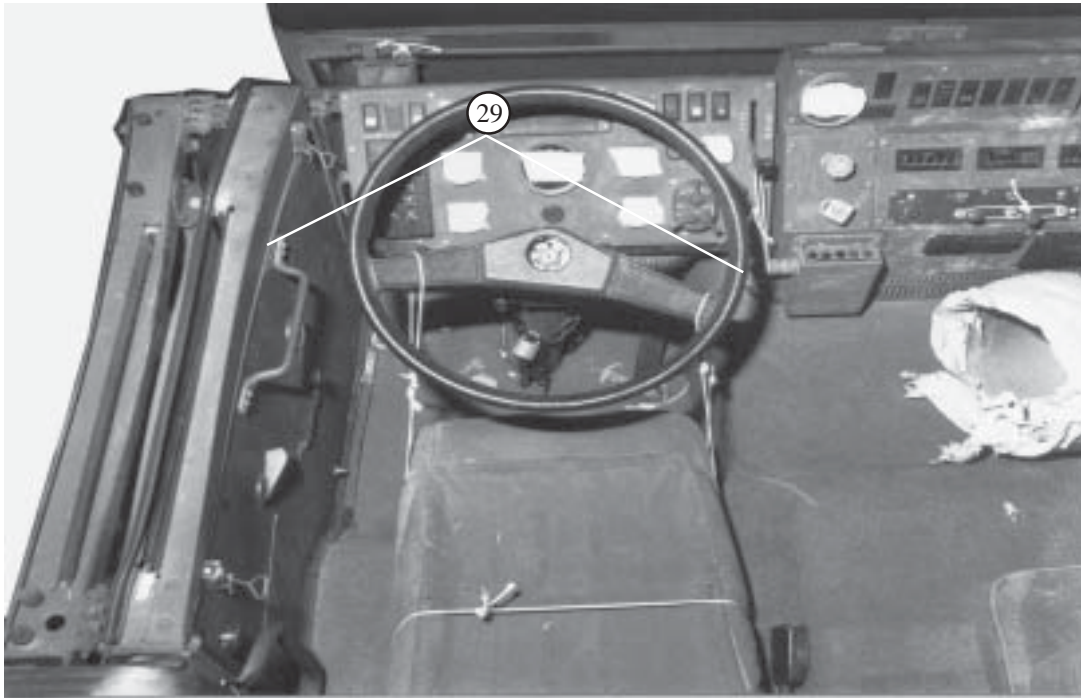

- ②9 Secure the ladder in place with a length of 1/2 -inch tubular nylon webbing.
- ③0 Safety tie the dump body braces on the right and left sides to their brackets with type III nylon cord.
- ③1 Ensure the dump body pins on both sides are installed in the locked position.

Figure 4-13. Truck prepared (Continued)

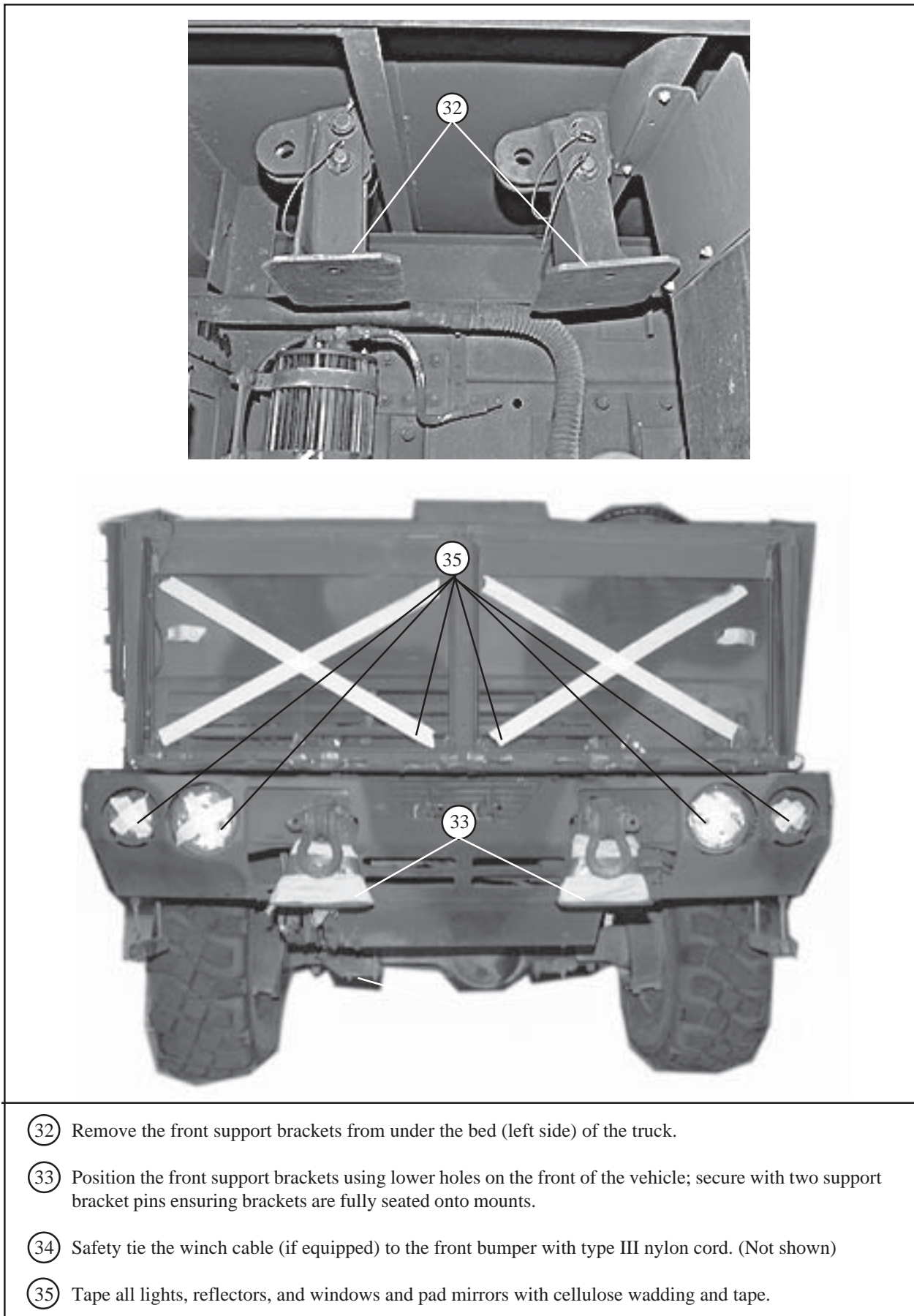
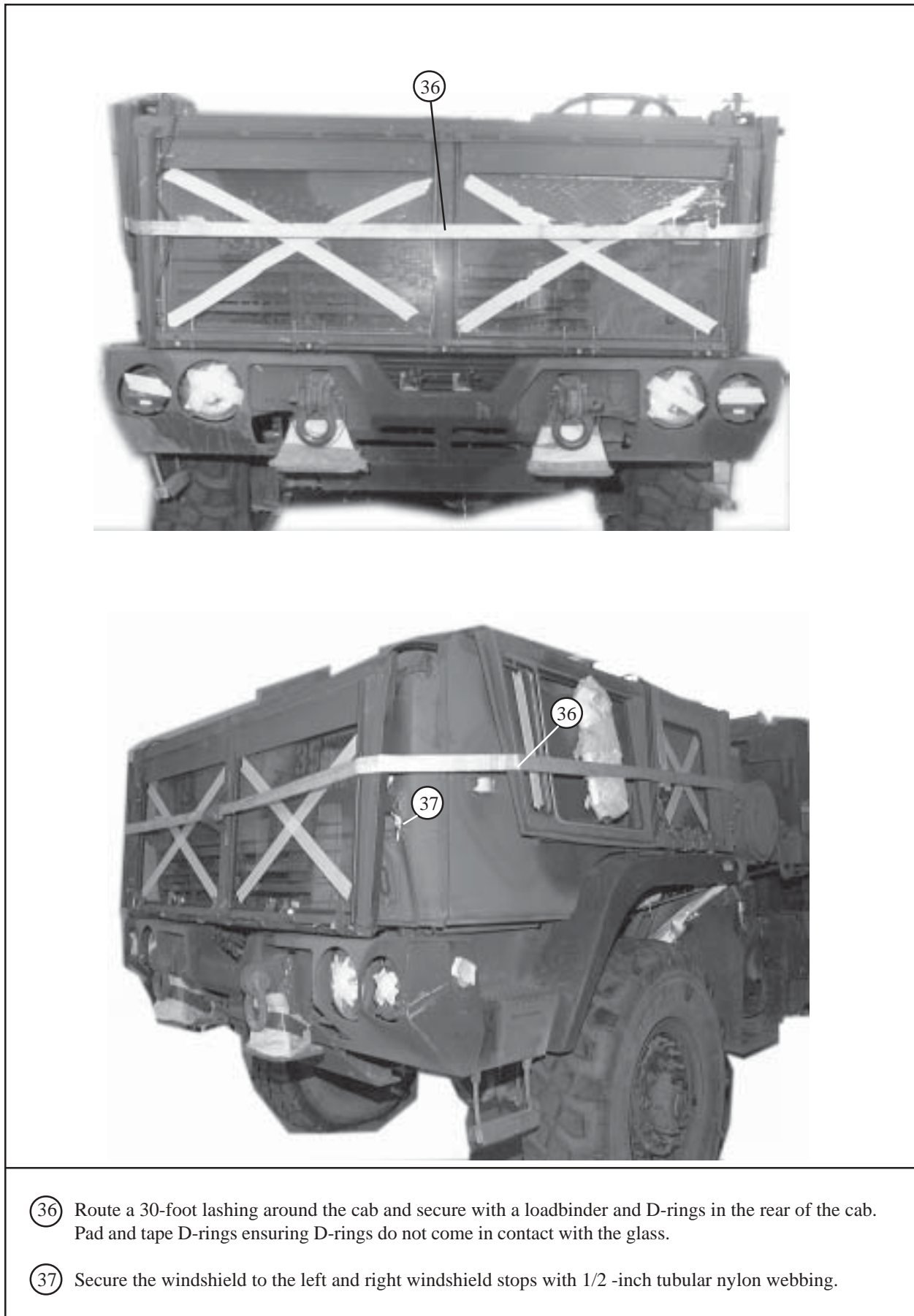
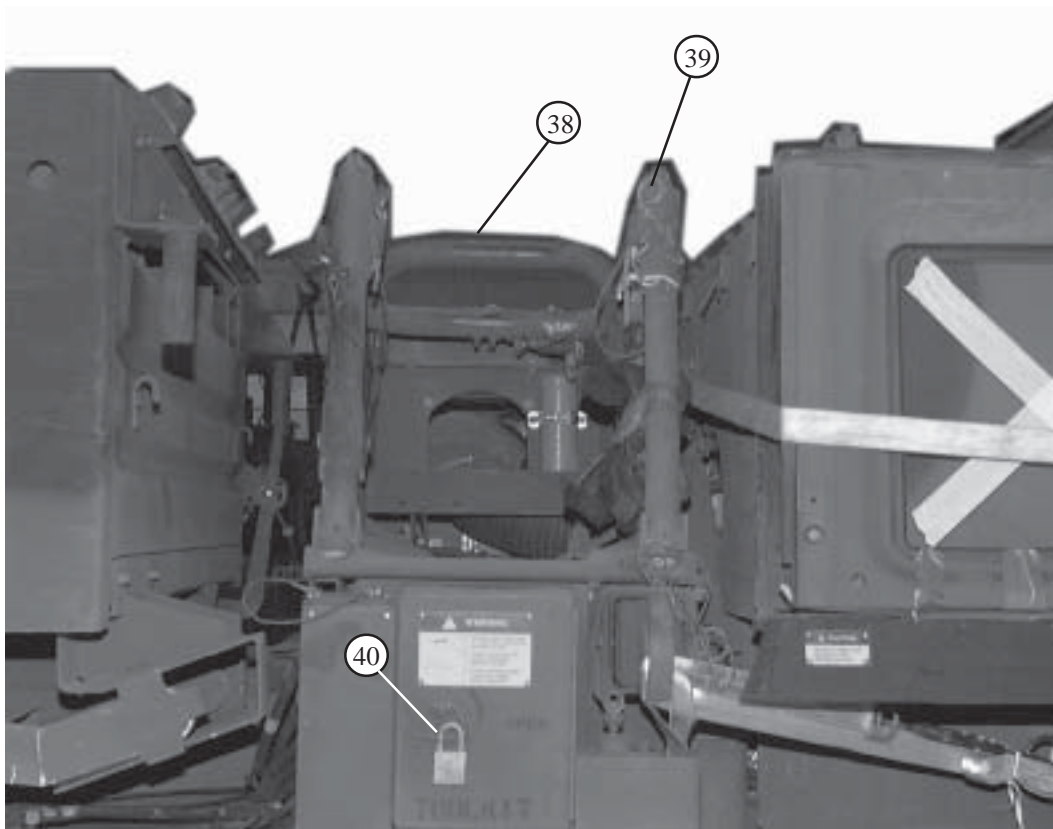

Figure 4-13. Truck prepared (Continued)



- ③⑥ Route a 30-foot lashing around the cab and secure with a loadbinder and D-rings in the rear of the cab. Pad and tape D-rings ensuring D-rings do not come in contact with the glass.
- ③⑦ Secure the windshield to the left and right windshield stops with 1/2 -inch tubular nylon webbing.

Figure 4-13. Truck prepared (Continued)



- ③⑧ Retract the spare tire carrier and secure with 1/2-inch tubular nylon webbing.
- ③⑨ Tape the chains and pins in place on the spare tire carrier.
- ④⑩ Secure the tool kit access panel with a length of type III nylon cord (if not secured).

Figure 4-13. Truck prepared (Continued)

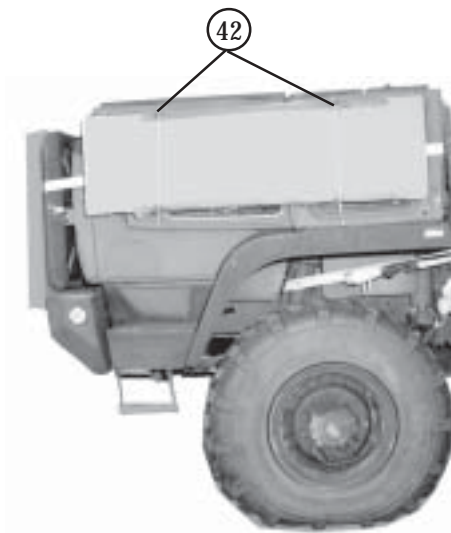
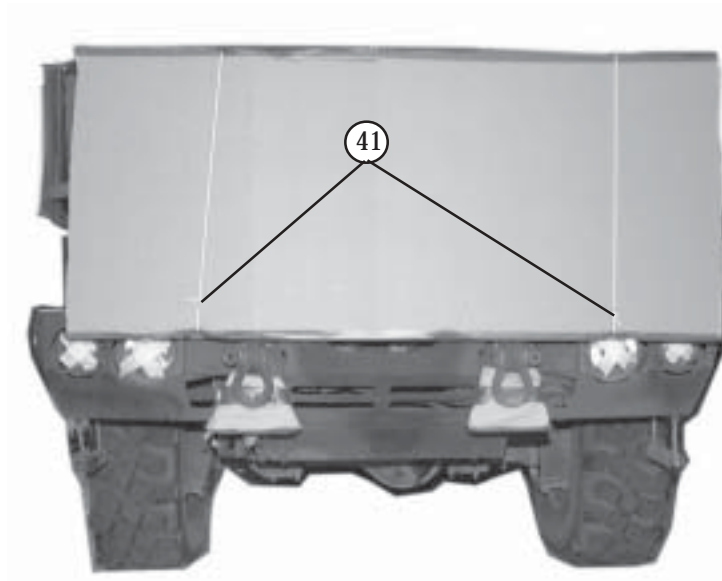

- ④1 Place a 36- by 80-inch piece of honeycomb on the windshield. Tape edges and secure it with two lengths of type III nylon cord.
- ④2 Place one 18- by 60-inch piece of honeycomb on the left side window and one piece on the right side window. Tape edges and secure each with two lengths of type III nylon cord.

Figure 4-13. Truck prepared (Continued)

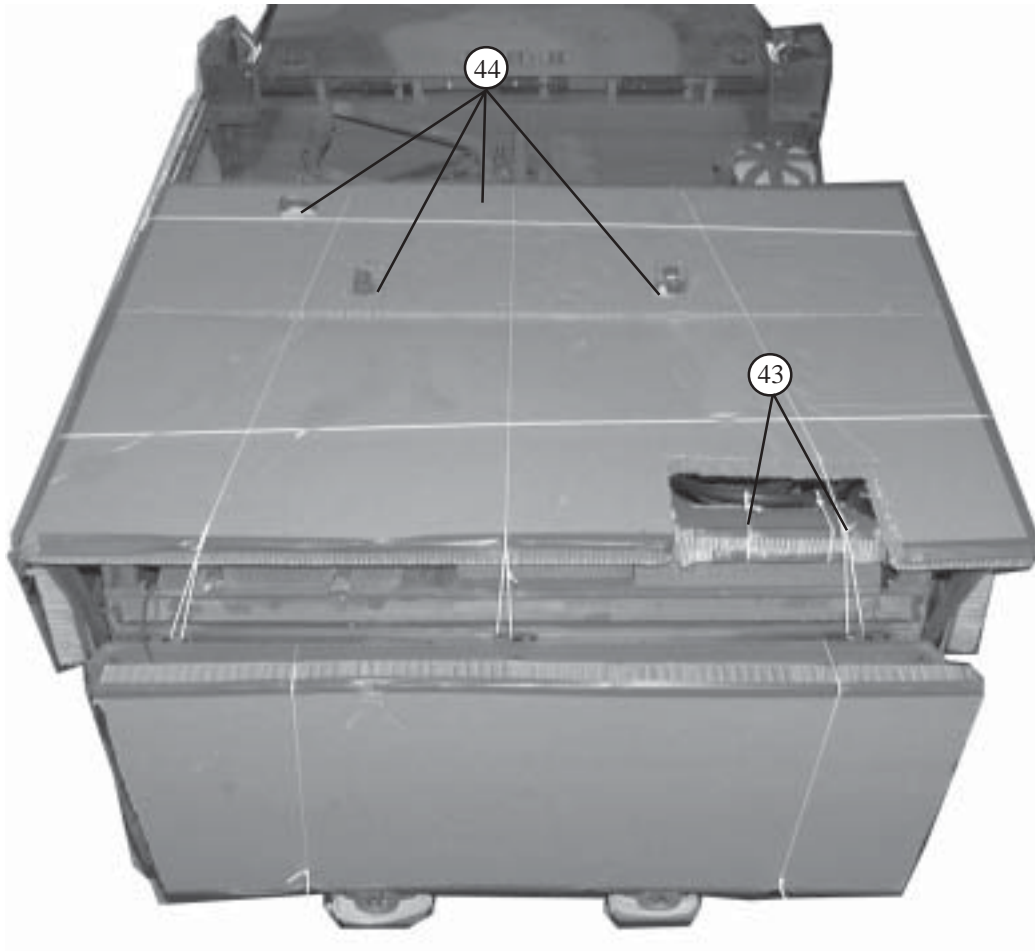

- ④③ Place a 36- by 96-inch piece of honeycomb over the driver's compartment. Cut out a section for the steering wheel 21- by 12-inches deep and place it over the instrument panel in the cab. Tape all edges with cloth-backed tape.
- ④④ Place a 28- by 96-inch piece of honeycomb with cutouts for the three davit holders behind the 36- by 96-inch piece of honeycomb. Tape all edges with cloth-backed tape. Secure all pieces with type III nylon cord.

Figure 4-13. Truck prepared (Continued)

Note: Hoses that will interfere with the attachment of the suspension slings should be tied back.

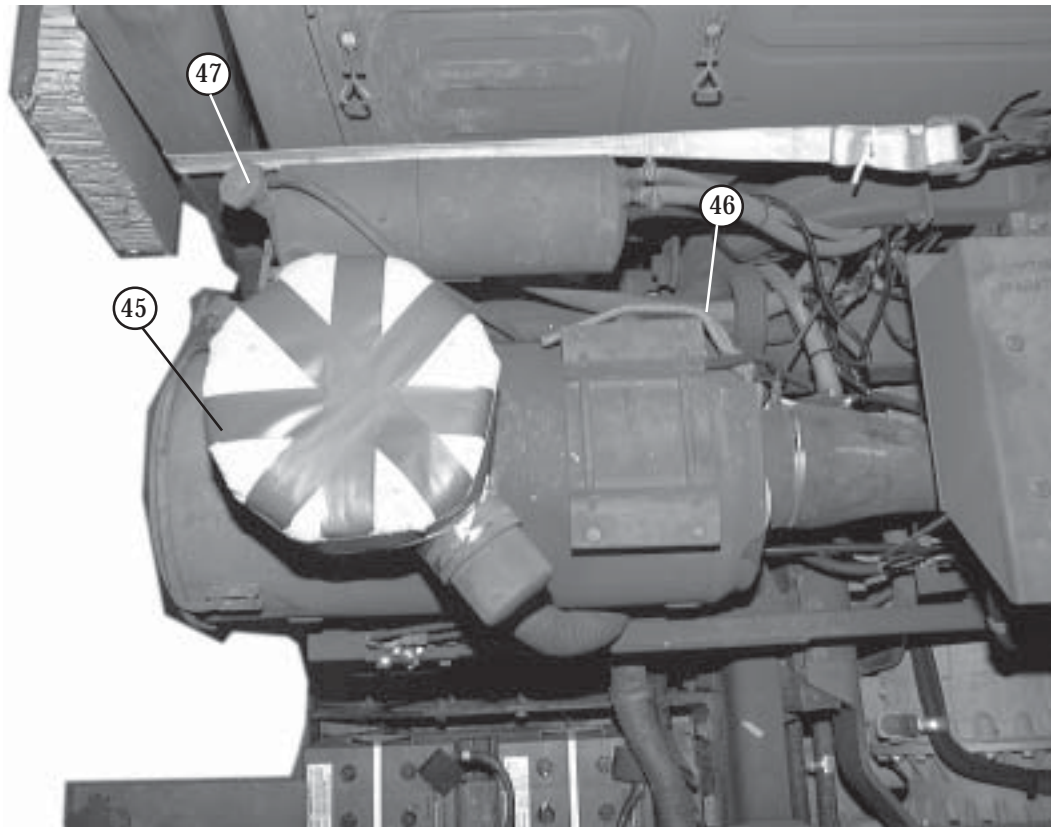

- ④5 Wrap the air intake fitting with cellulose wadding and secure with cloth-backed tape. Secure the end hose out of the way with type III nylon cord.
- ④6 Pad the lower air intake fitting with felt and secure with cloth-backed tape.
- ④7 Ensure the radiator pressure cap is secure.

Figure 4-13. Truck prepared (Continued)

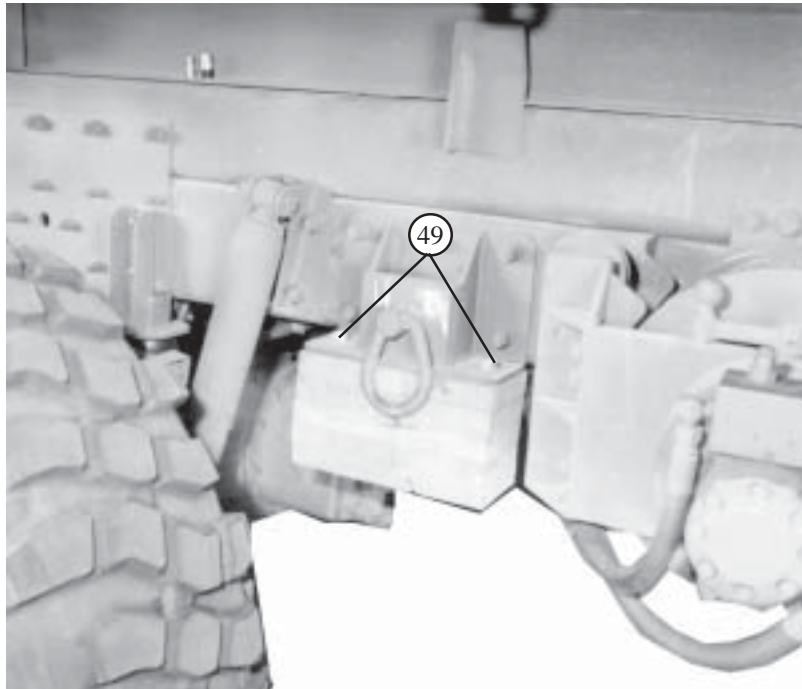
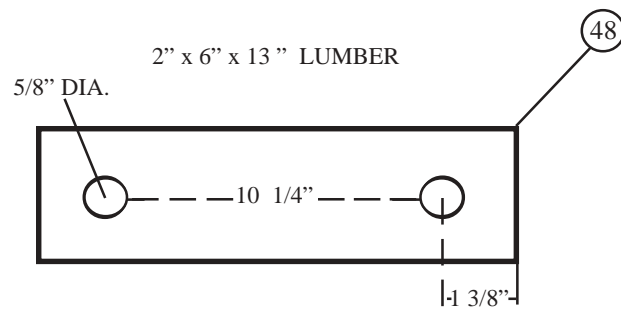

- 48 Cut ten 2- by 6- by 13-inch pieces of lumber. Drill two 5/8-inch diameter holes 1 3/8-inches from the edge, with a 10 1/4-inch center to center hole measurement in each piece of lumber.
- 49 Bolt five 2- by 6- by 13-inch pieces of lumber to the left and right side frame pads using two 1/2- by 10-inch bolt sand washers on each side.

Figure 4-13. Truck prepared (Continued)

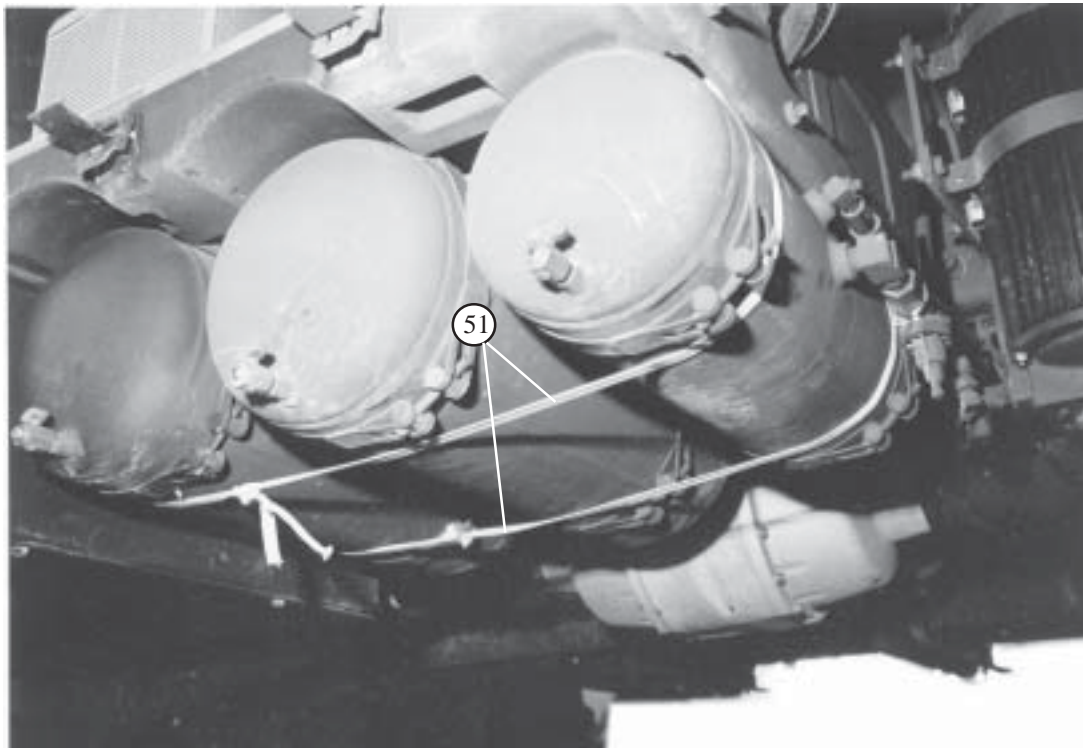
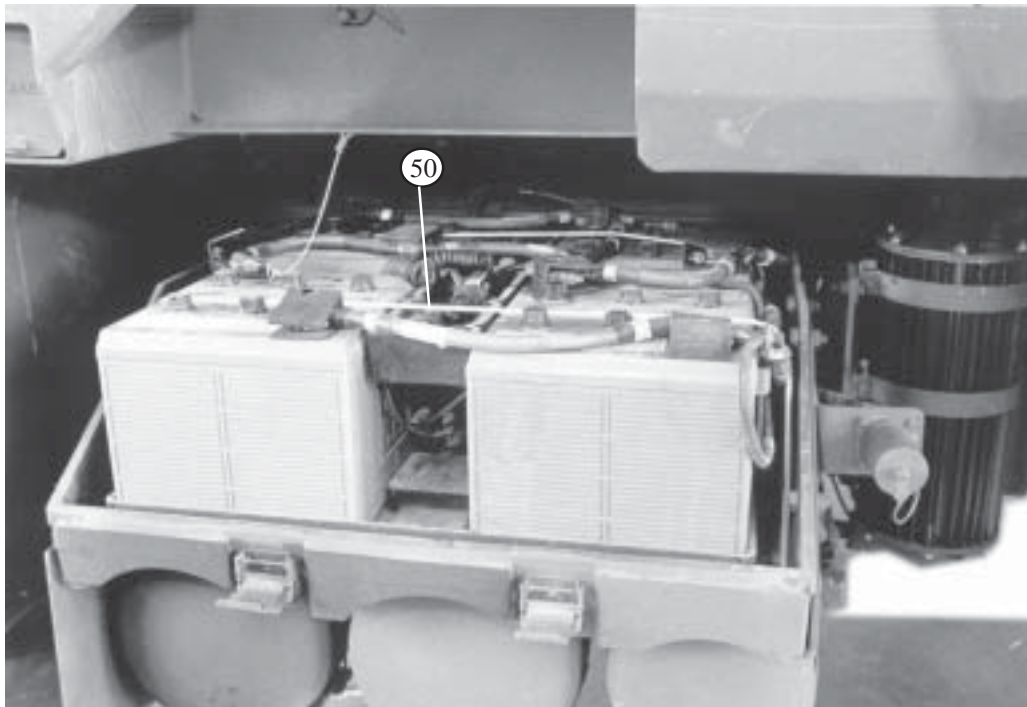

- ⑤0 Remove the battery box cover and secure the batteries in place with two lengths of 1/2-inch tubular nylon webbing. Prepare the batteries according to FM 4-20.102/NAVSEA SS400-AB-MMO-010/TO 13C7-1-5.
- ⑤1 Run the nylon webbing over the batteries down through the battery box and under the air tanks. Secure with trucker's hitch knot.

Figure 4-13. Truck prepared (Continued)

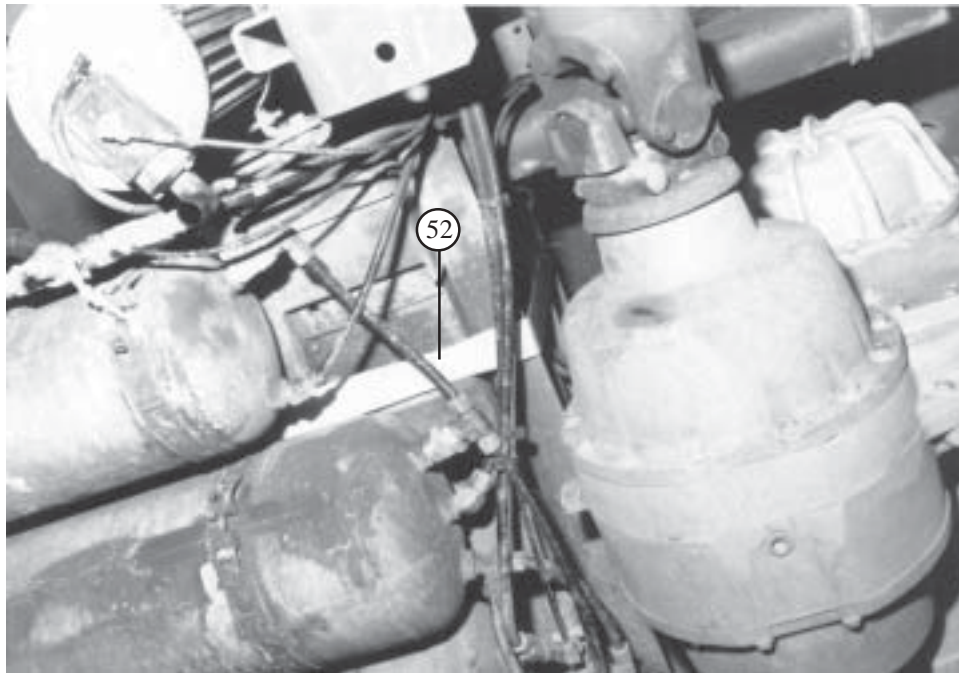
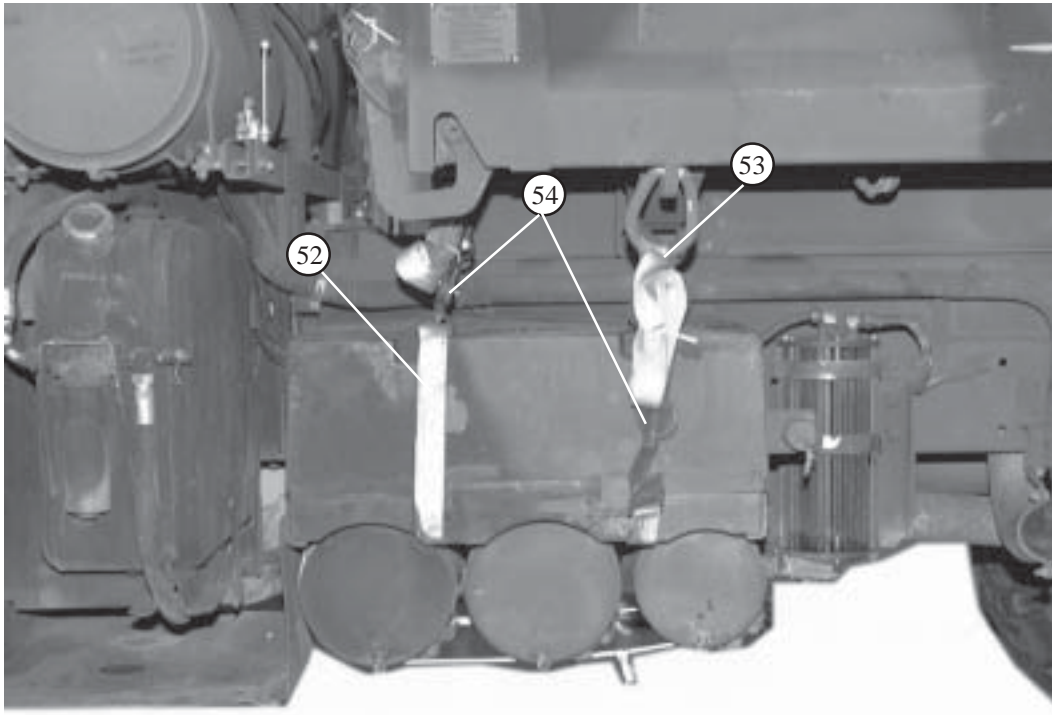

- ⑤② Replace the cover. Route a 15-foot lashing around the main frame, under the battery box, between the air tanks.
- ⑤③ Route a 15-foot lashing through tiedown point #1 and around the main frame, under the battery box, between the air tanks.
- ⑤④ Secure with D-ring and loadbinder on the front of battery box cover. Pad with felt or cellulose wadding.

Note: Ensure the lashings are underneath all hoses and not crimped.

Figure 4-13. Truck prepared (Continued)

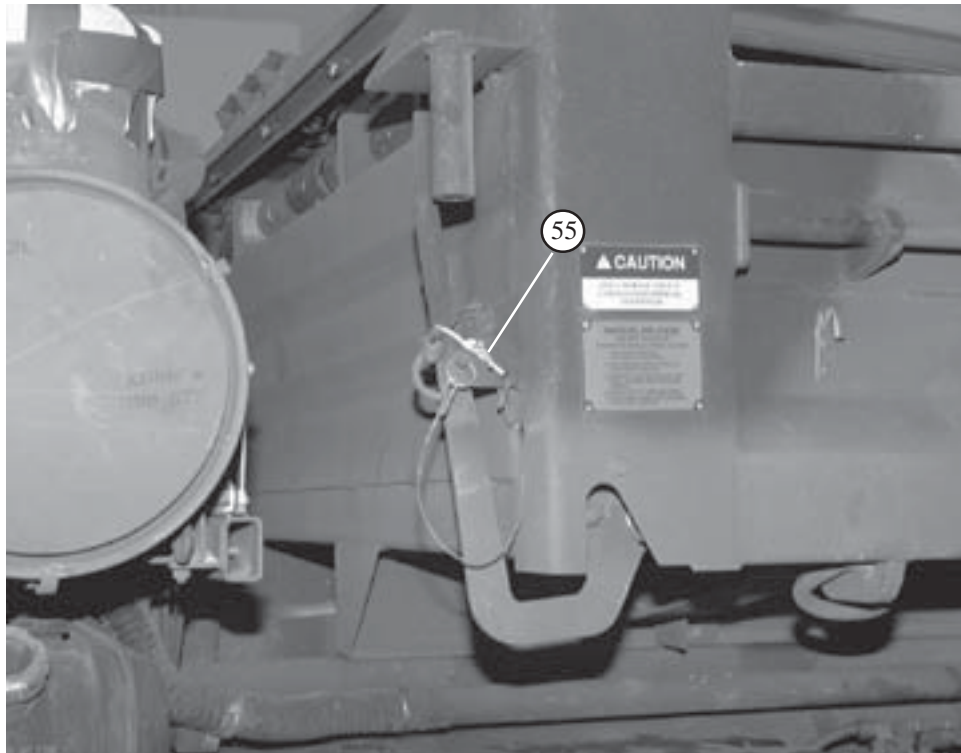

- 55 Safety tie the dump manual release lever with type III nylon cord.

Figure 4-13. Truck prepared (Continued)

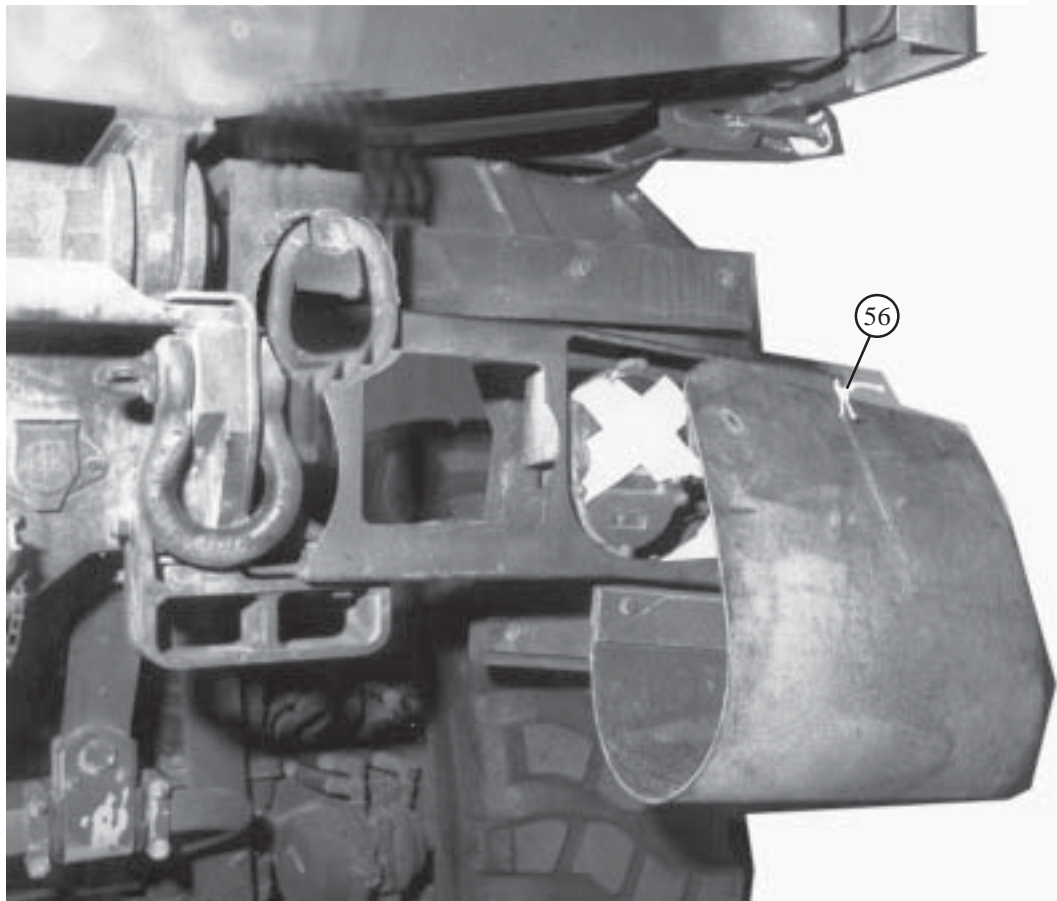

56 Tie the mud flaps up with type III nylon cord.

Figure 4-13. Truck prepared (Continued)

4-6. Stowing Accompanying Load

Stow the vehicle's roof, spare tire, and dump body cab protector (overhead protector) in the truck bed as shown in *Figure 4-14*. The ballast box is constructed as shown in *Figure 4-15*. Ballast materials must be packaged to prevent spillage or leakage during use. The configuration consists of a box constructed to contain a minimum of 2,000 pounds and a maximum of 2,200 pounds for ballast.

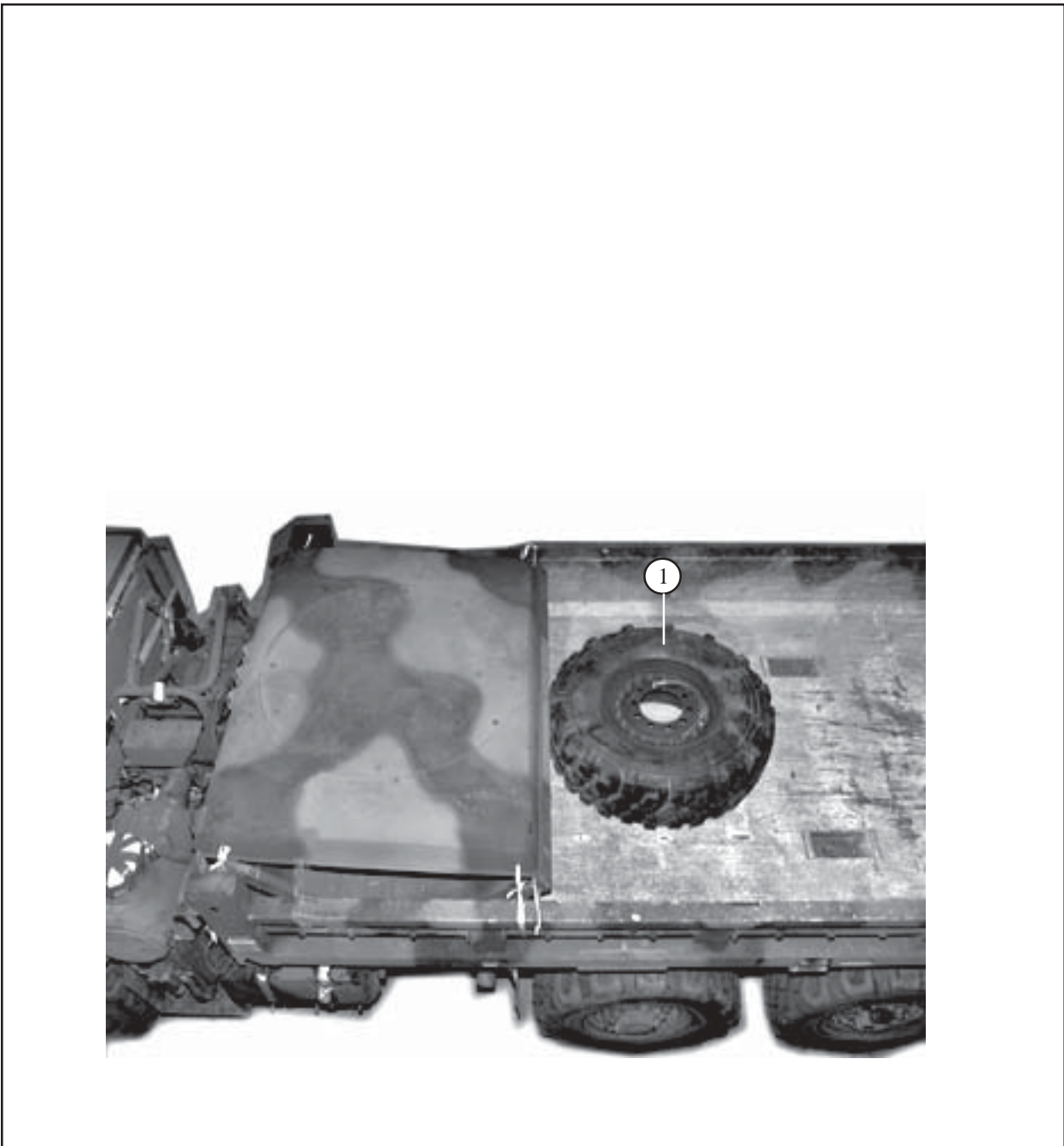

- ① Place the spare tire in the center of the dump truck bed behind the roof and cab protector.

Figure 4-14. Accompanying load stowed

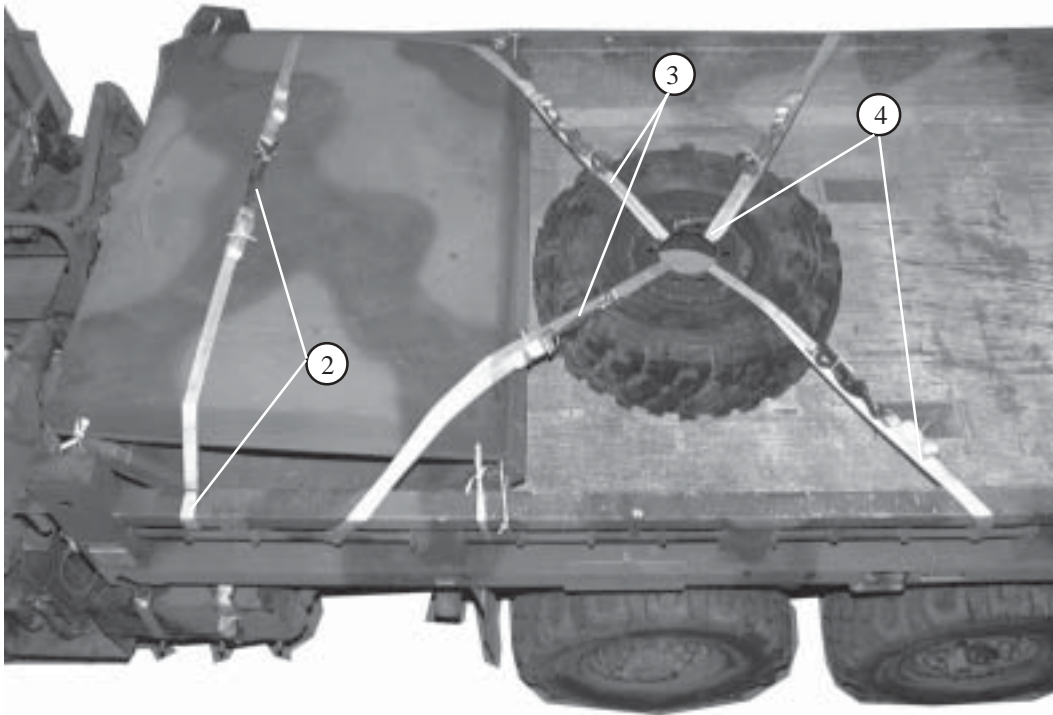

- ② Route a 15-foot lashing through the front hole on the left side of the dump truck bed and back through it's own D-ring. Repeat for the right side. Secure with D-rings and a loadbinder on top of the roof.
- ③ Route a 15-foot lashing around the fourth set of tie bars from the rear on the left side of the dump bed and over the roof and through the spare tire center hole. Secure with a D-ring and loadbinder. Repeat for the right side.
- ④ Route a 15-foot lashing around the second set of tie bars from the rear on the left side of the dump bed. Repeat for the right side. Route each lashing through the lug nut holes on the spare tire. Secure with D-rings and loadbinder.
- ⑤ Construct an ballast box as shown in the diagram in *Figure 4-15*.

Figure 4-14. Accompanying load stowed (Continued)

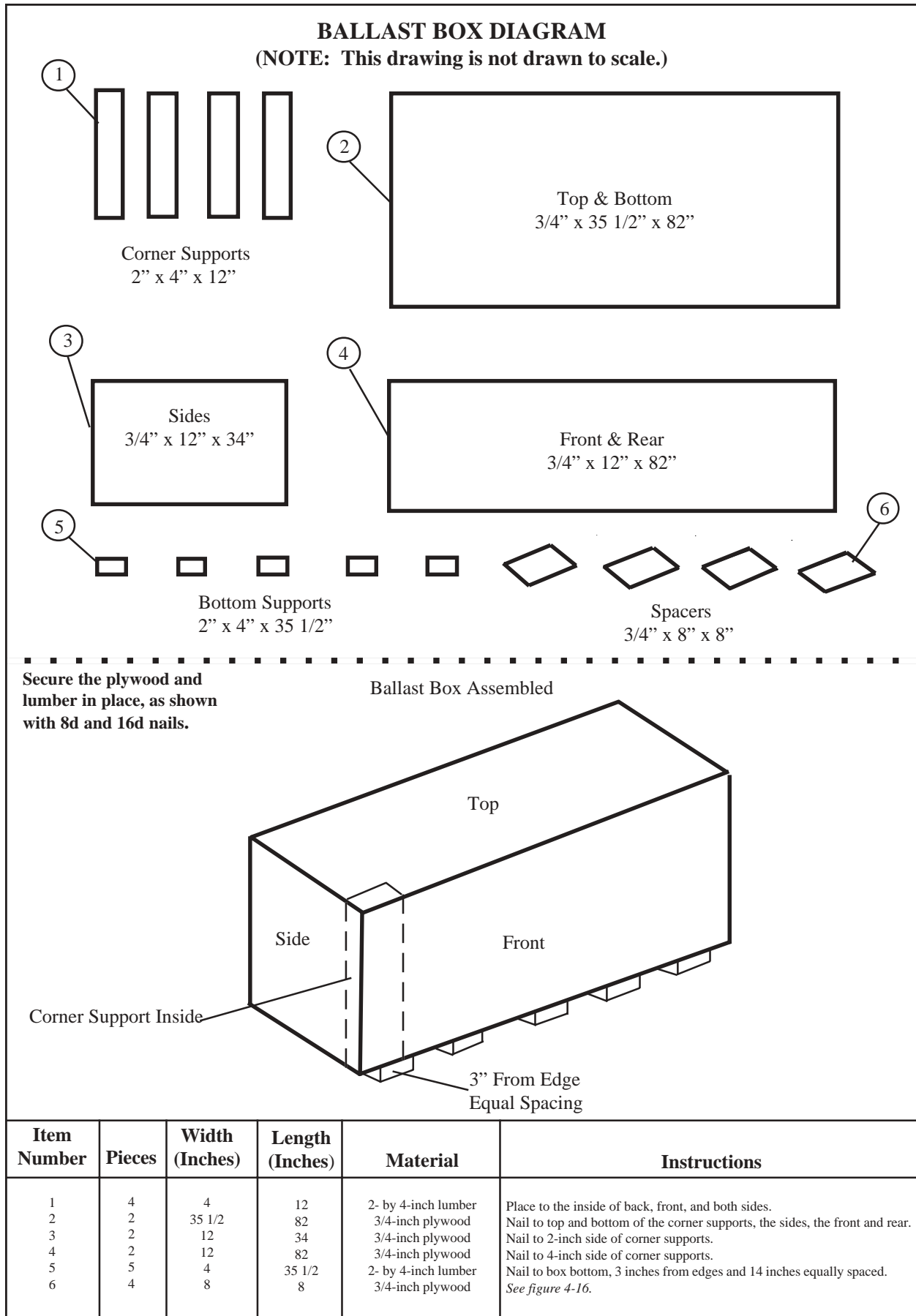
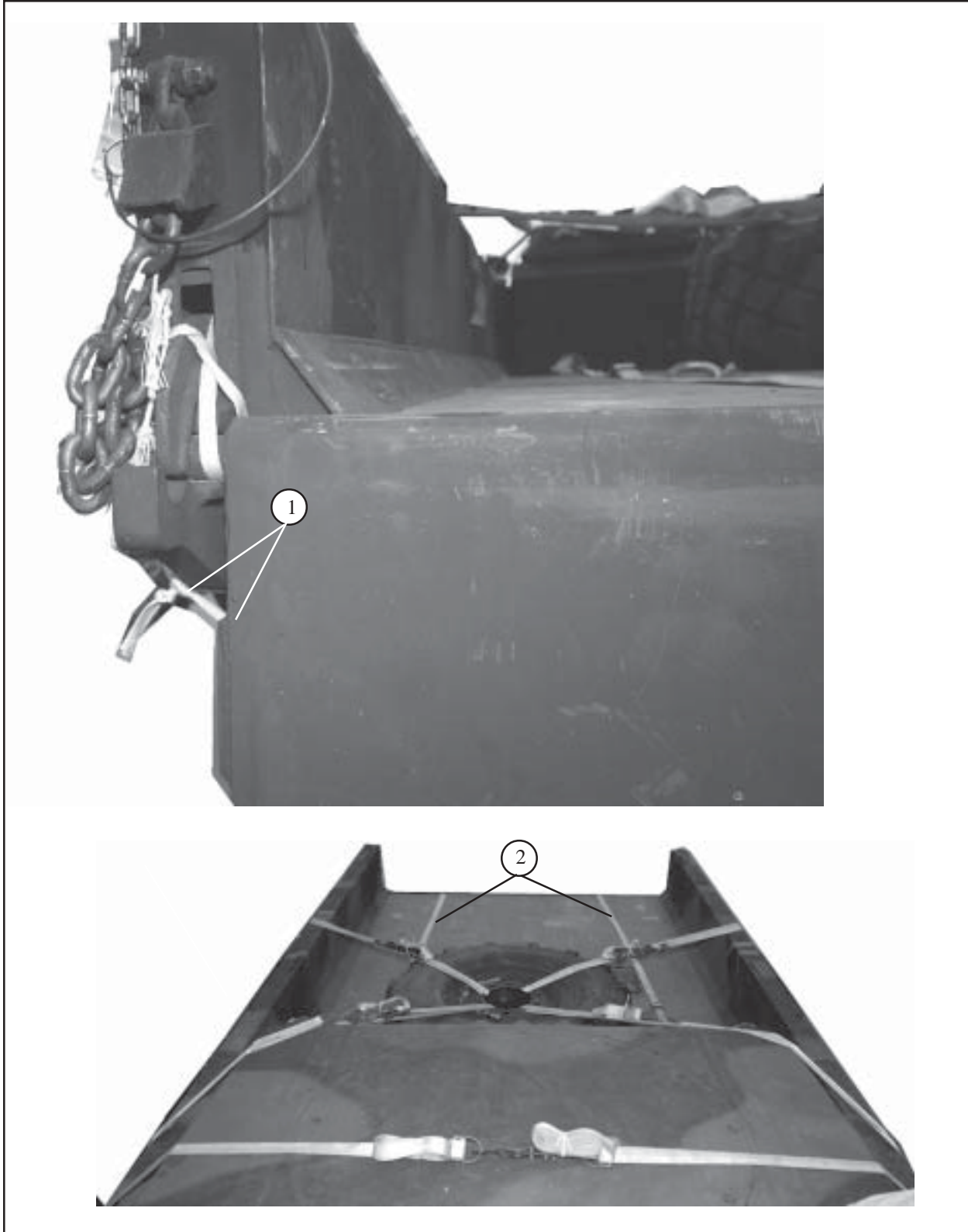

Figure 4-15. Ballast box construction



- ① Lower the tailgate to the open position and secure the tailgate releases with 1/2 inch tubular nylon webbing.
- ② Form two 30-foot lashings and place them lengthwise in the dump truck bed. Route one running end of each lashing underneath the tailgate through the rear tiedown points.

Figure 4-16. Ballast box stowed

CAUTION
This load requires a ballast box of 2,000 pounds to attain the required Center of Balance (CB).

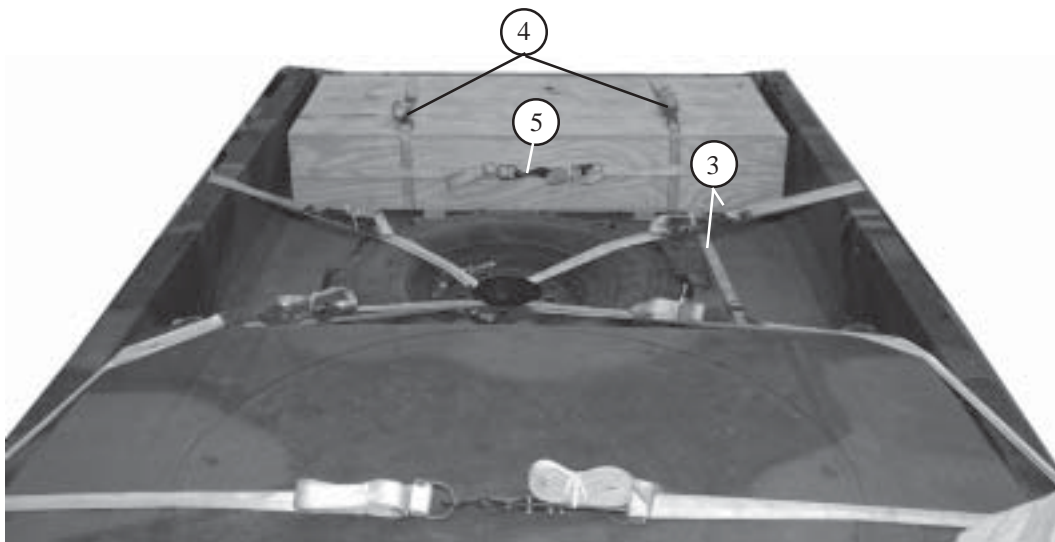

- ③ Position the ballast box on top of the 30-foot lashings in the truck bed centered 2-inches from the rear edge of the truck bed.
- ④ Route two 15-foot lashings around the ballast box and attach with D-rings and loadbinders.
- ⑤ Route a 30-foot lashing around the ballast box (lateral) and attach with D-rings and a loadbinder.

Figure 4-16. Ballast box stowed (Continued)

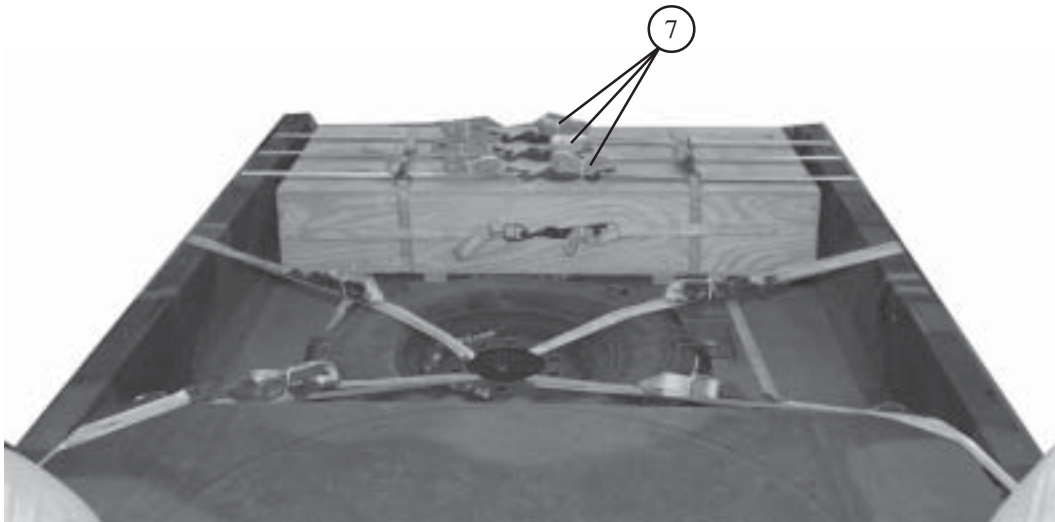
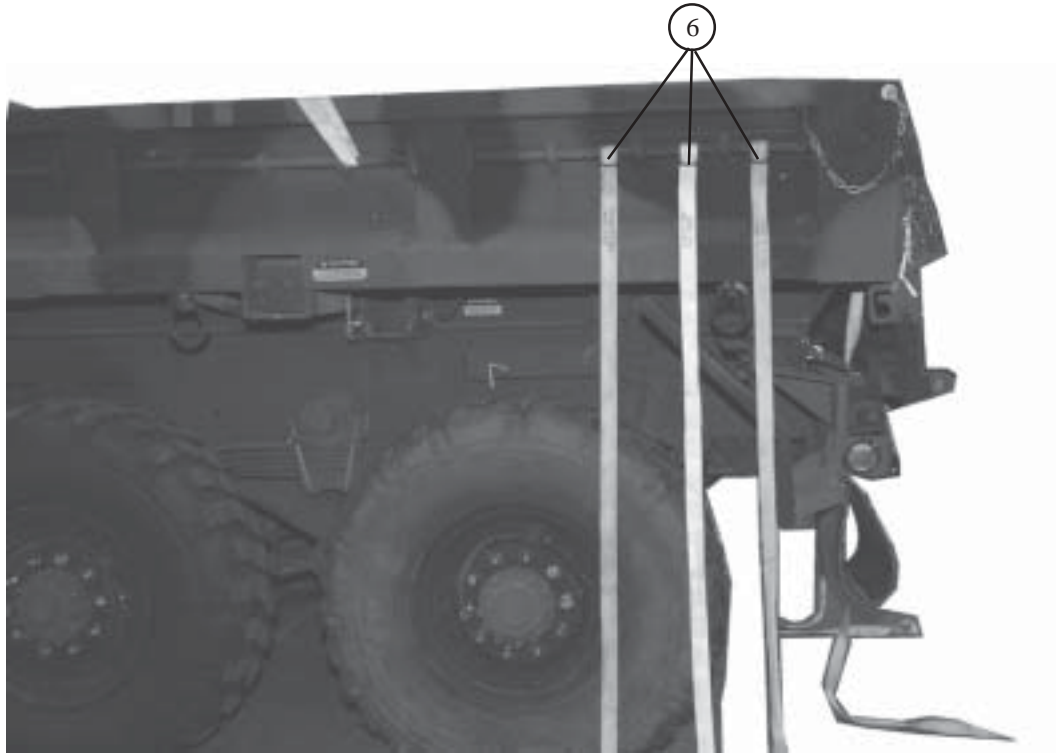

- ⑥ Route three 15-foot lashings around the rear set of tie bars on each side of the dump truck.
- ⑦ Route the lashings on top of the ballast box, underneath the two 30-foot lashings on the box. Secure with D-rings and loadbinders.

Figure 4-16. Ballast box stowed (Continued)

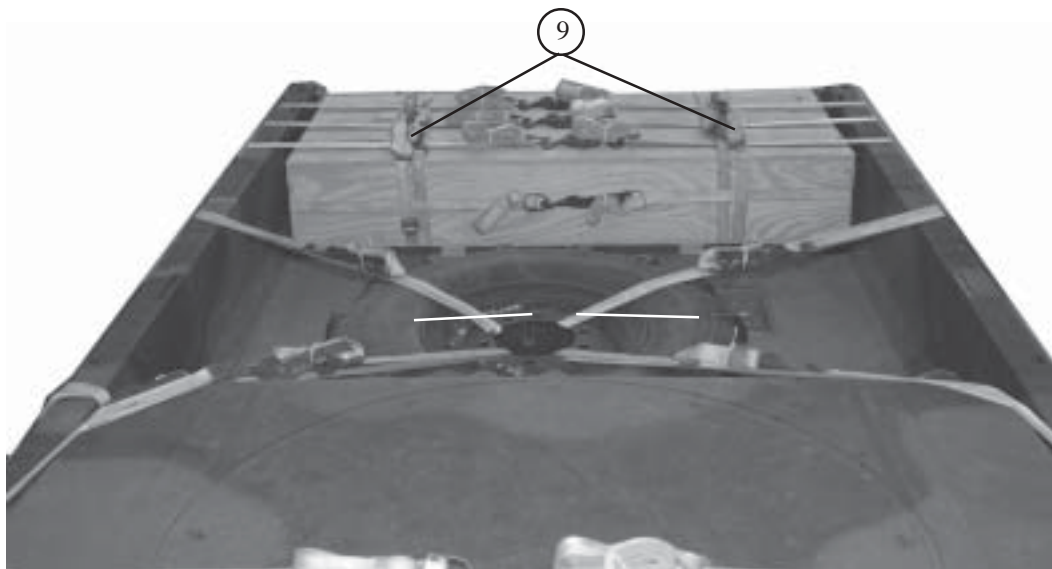
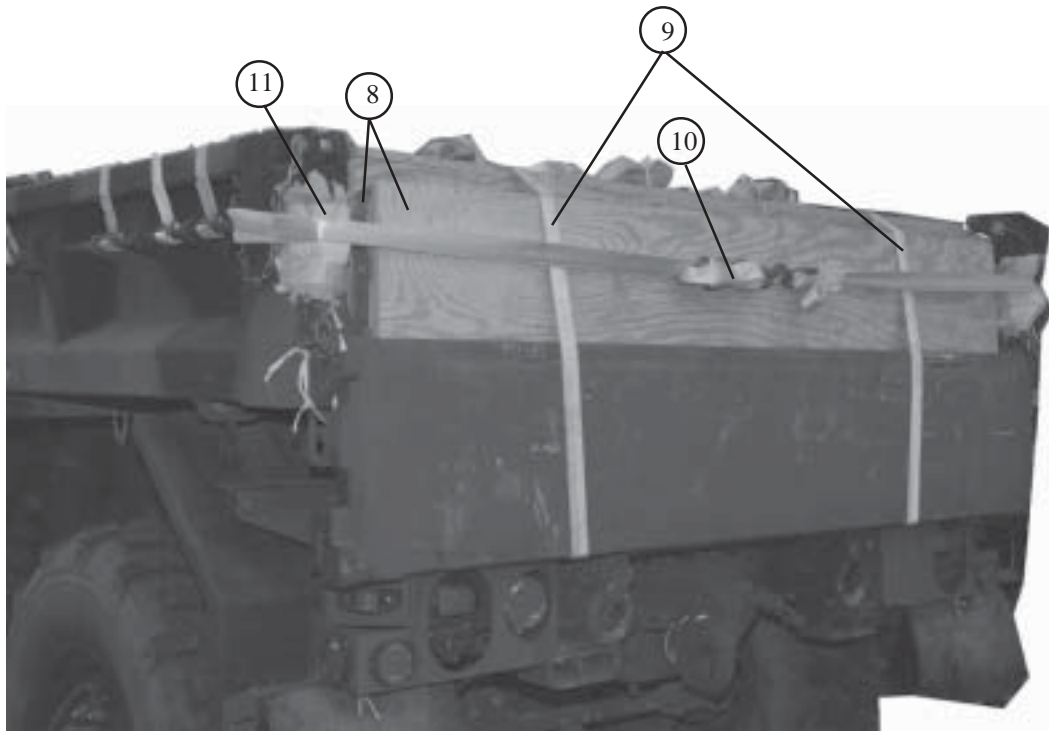

- ⑧ Place a 82- by 13-inch piece of honeycomb against the rear of the box. Place an 82- by 13-inch piece of plywood against the honeycomb.
- ⑨ Position the four ballast box spacers to the front and rear edges of the ballast box , underneath the two 30-foot lashings. Secure the two 30-foot lashings on top of the ballast box with D-rings and loadbinders.
- ⑩ Form a 30-foot lashing and route it through the right tie bar, around the plywood, through the left tie bar and secure in the rear of the plywood with a D-ring and loadbinder.
- ⑪ Pad all edges with cellulose wadding and tape in place.

Figure 4-16. Ballast box stowed (Continued)

4-7. Lifting and Positioning Truck

Install lifting slings on the M1094 dump truck and position the truck as shown in *Figure 4-17* and as described below.

a. Assemble a lifting kit using two large clevises and a doubled 20-foot (4-loop), type XXVI sling (10-foot sling) attached to each rear lifting point. Attach a 9-foot (4-loop), type XXVI sling to each front lifting point with a 9 1/2 ton screw pin clevis.

b. Position the 5-ton dump truck so that the rear bumper pads are flush with the front honeycomb stack 1.

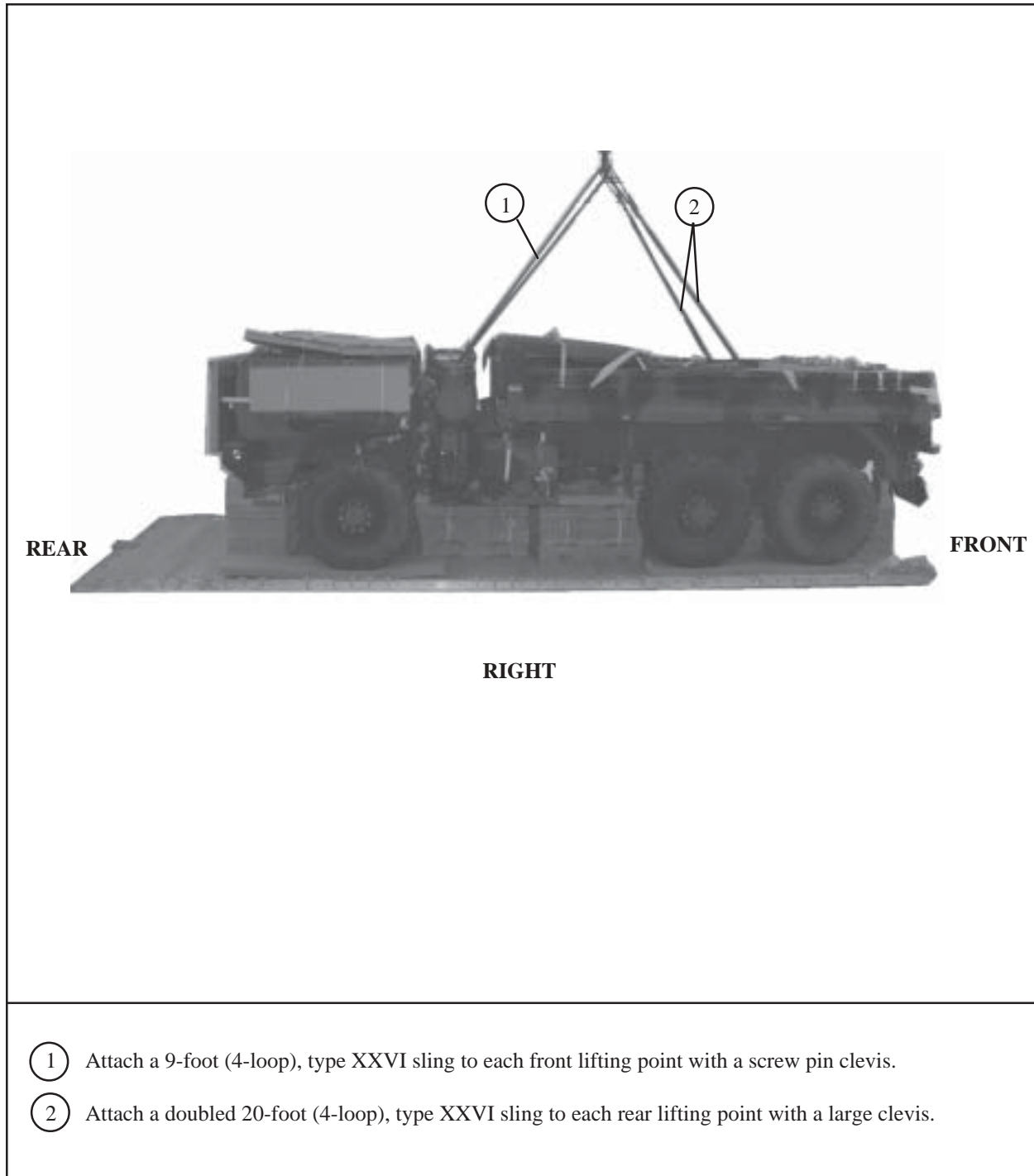
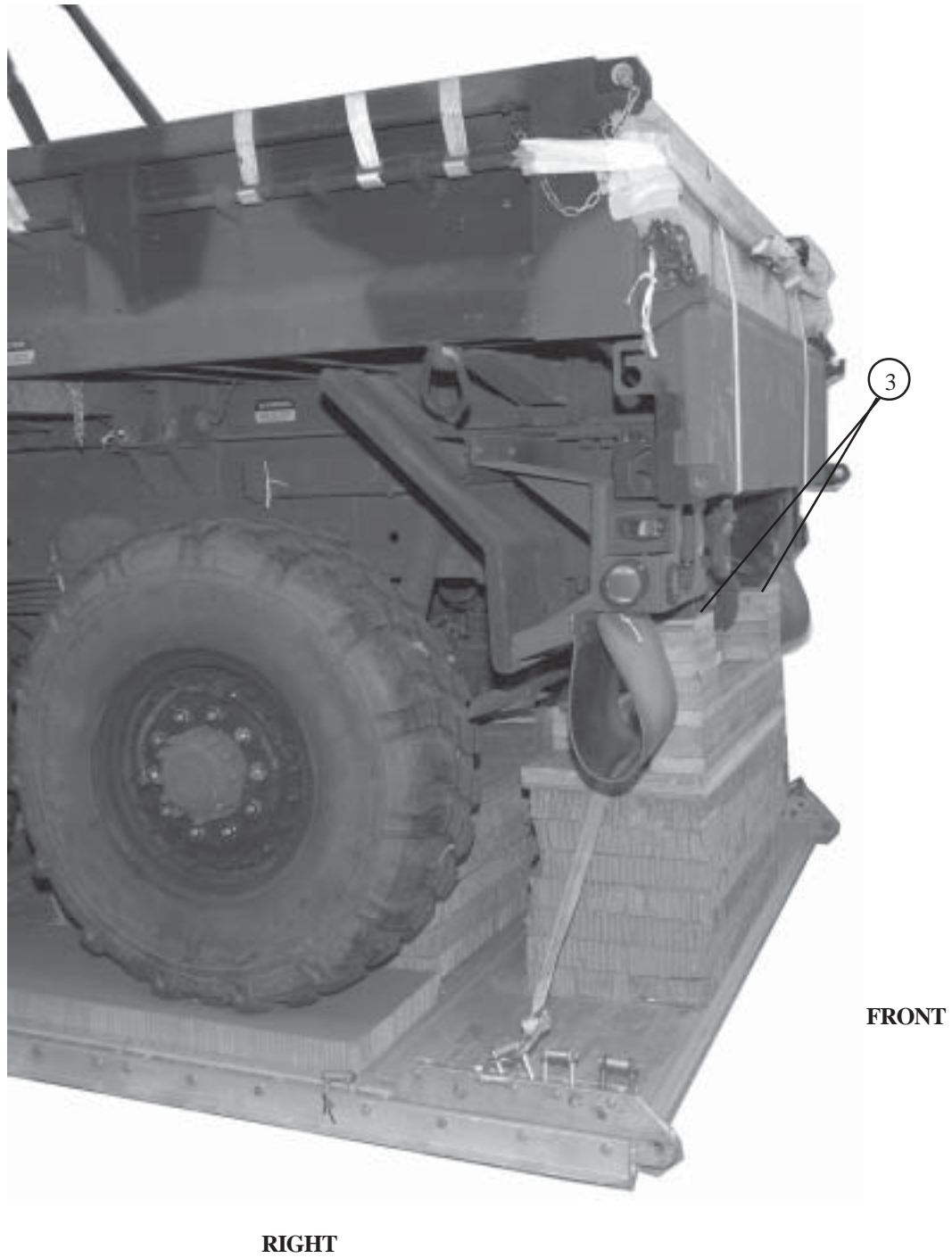

Figure 4-17. Truck positioned on the platform



- ③ Position the dump truck so that the rear bumper pads are flush with the front edge of stack 1.

Figure 4-17. Truck positioned on the platform (Continued)

4-8. Installing Lashings

Install lashings according to FM 4-20.102/NAVSEA SS400-AB-MMO-010/TO 13C7-1-5 and as shown in *Figure 4-18*.

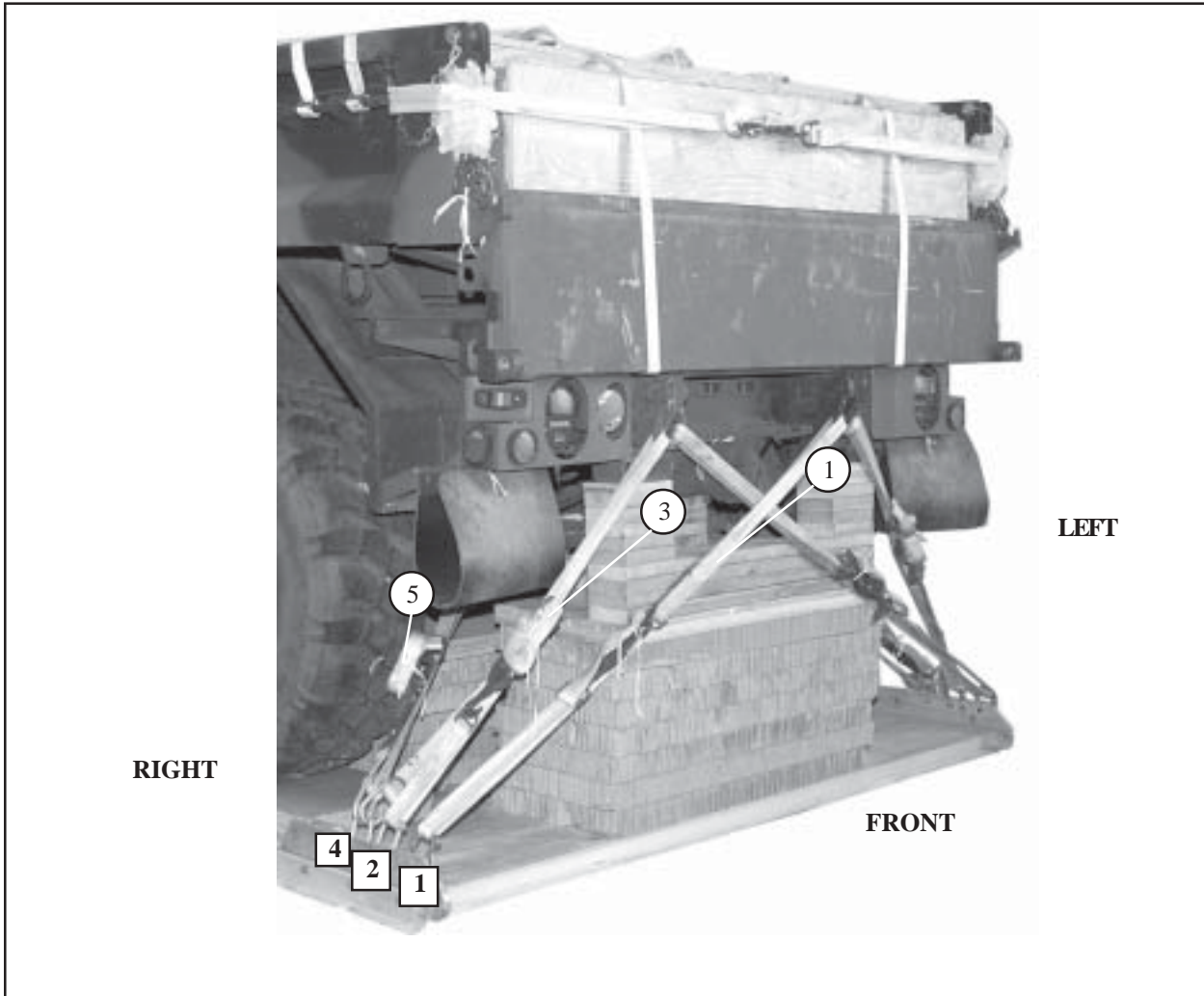

Lashing Number	Tiedown Clevis Number	Instructions
1	1	Pass lashing: Through vehicle right rear tiedown shackle.
2	1A	Through vehicle left rear tiedown shackle.
3	2	Through vehicle left rear tiedown shackle.
4	2A	Through vehicle right rear tiedown shackle.
5	4	Around the vehicle stabilizer left rear side.
6	4A	Around the vehicle stabilizer right rear side.

Figure 4-18. Truck positioned and lashed to the platform

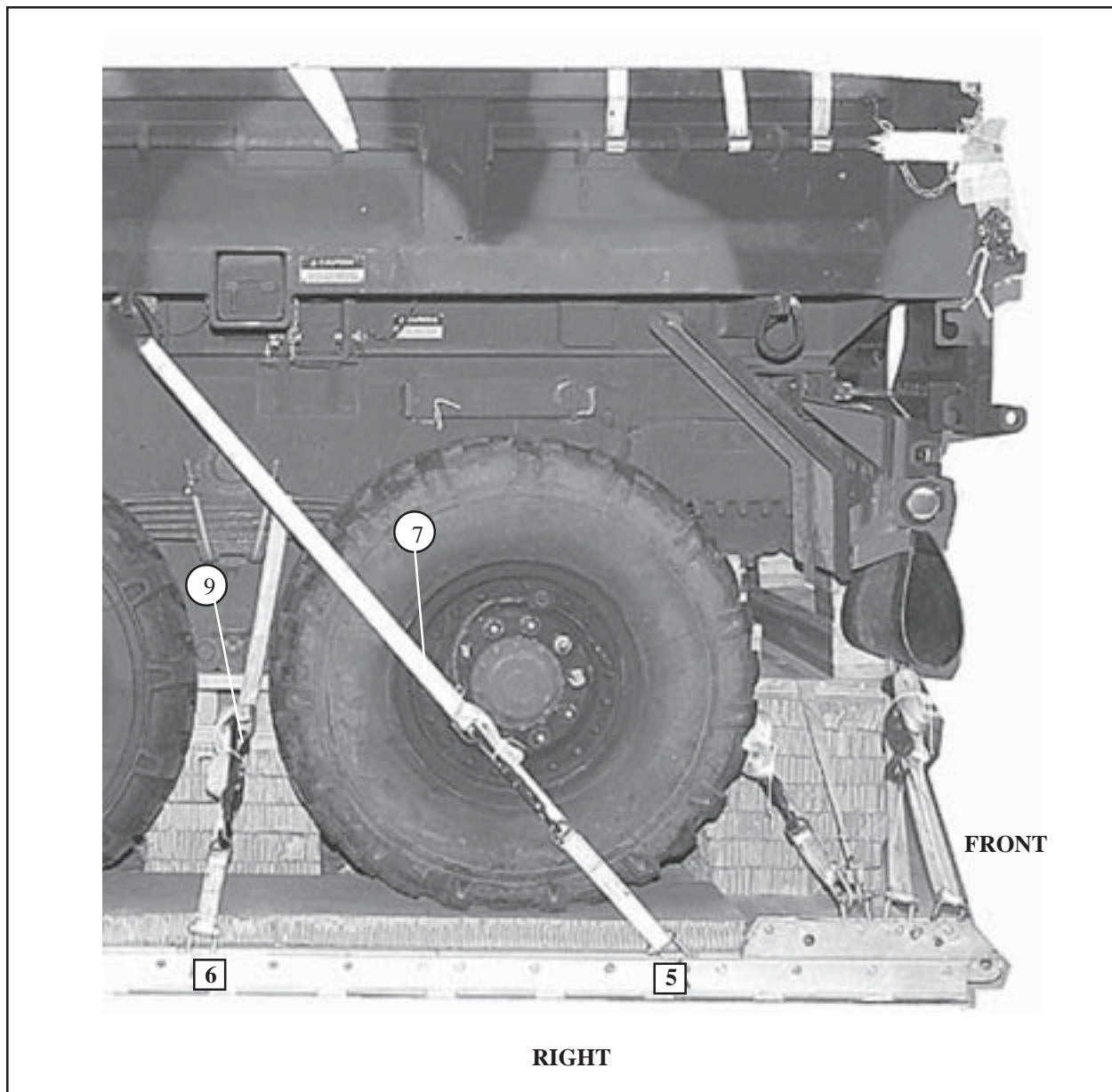

Lashing Number	Tiedown Clevis Number	Instructions
7	5	Pass lashing: Through tiedown point #3 on the vehicle left side.
8	5A	Through tiedown point #3 on the vehicle right side.
9	6	Around the rear portion of the vehicle left leaf spring.
10	6A	Around the rear portion of the vehicle right leaf spring.

Figure 4-18. Truck positioned and lashed to the platform (Continued)

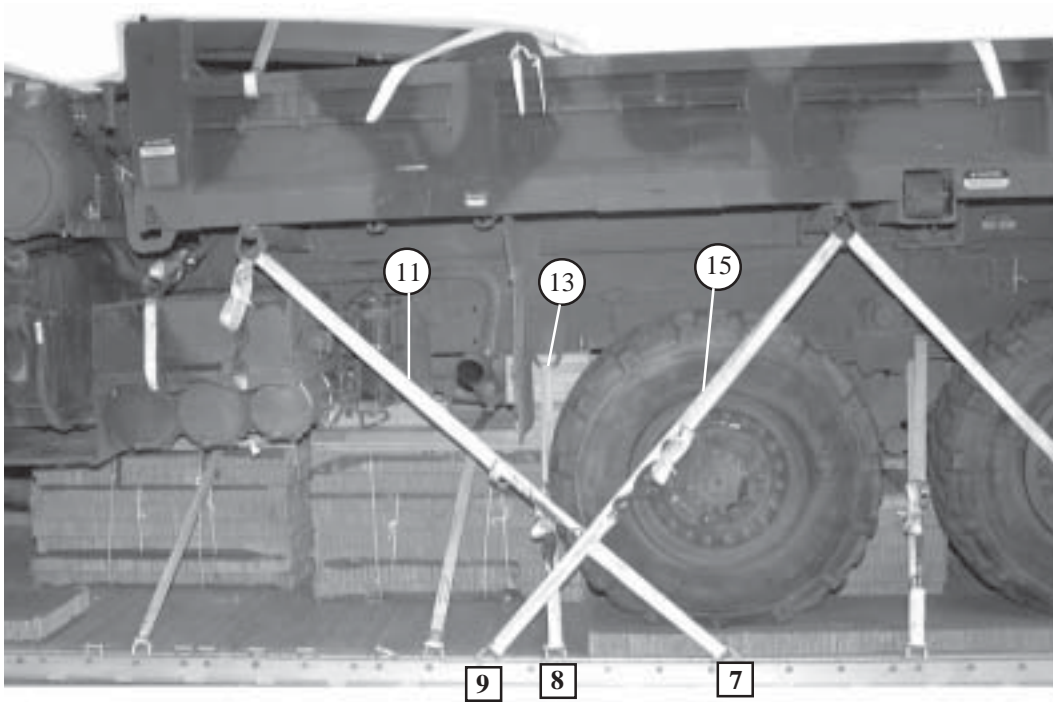

RIGHT

Lashing Number	Tiedown Clevis Number	Instructions
11	7	Pass lashing: Through the vehicle left tiedown point #1.
12	7A	Through the vehicle right tiedown point #1.
13	8	Through the vehicle left tiedown point #2.
14	8A	Through the vehicle right tiedown point #2.
15	9	Through the vehicle left tiedown point #3.
16	9A	Through the vehicle right tiedown point #3.

Figure 4-18. Truck positioned and lashed to the platform (Continued)

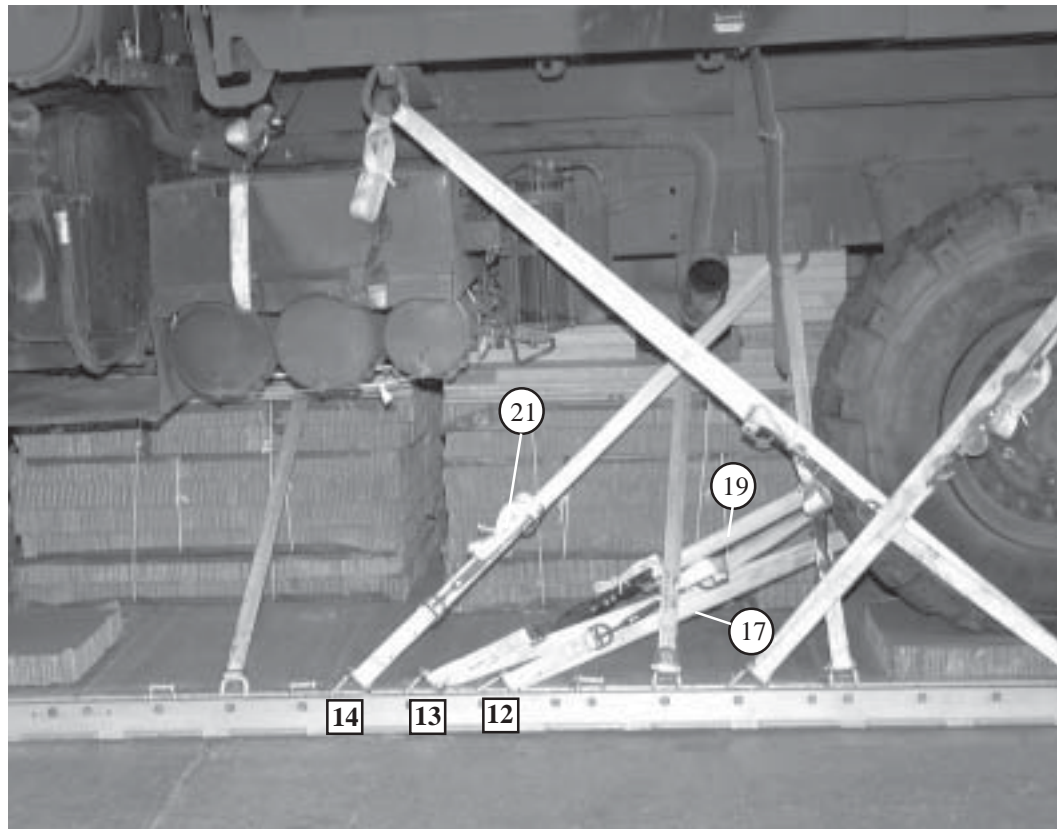

RIGHT

Lashing Number	Tiedown Clevis Number	Instructions
17	12	Pass lashing: Around the vehicle left side center axle, underneath all hoses.
18	12A	Around the vehicle right side center axle, underneath all hoses.
19	13	Around the vehicle left side center axle, underneath all hoses.
20	13A	Around the vehicle right side center axle, underneath all hoses.
21	14	Through tiedown point #2 on the vehicle left side.
22	14A	Through tiedown point #2 on the vehicle right side.

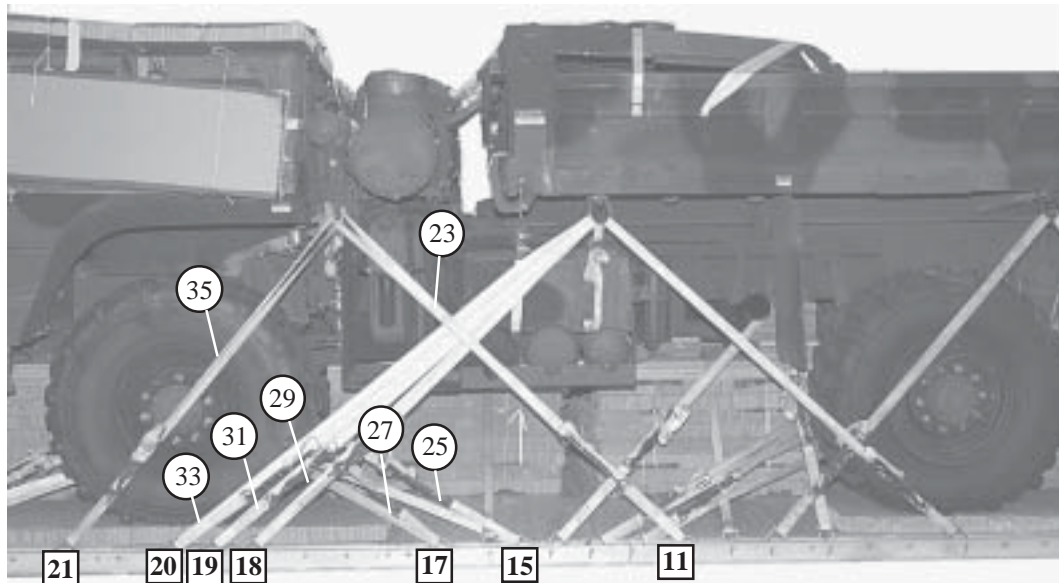

RIGHT

Lashing Number	Tiedown Clevis Number	Instructions
23	11	Pass lashing: Through vehicle left side outer lifting point.
24	11A	Through vehicle right side outer lifting point.
25	15	Around the vehicle left side front axle, underneath all hoses.
26	15A	Around the vehicle right side front axle, underneath all hoses.
27	17	Around the vehicle left side front axle, underneath all hoses.
28	17A	Around the vehicle right side front axle, underneath all hoses.
29	18	Through the vehicle left side tiedown point # 1.
30	18A	Through the vehicle right side tiedown point # 1.
31	19	Through the vehicle left side tiedown point # 1.
32	19A	Through the vehicle right side tiedown point # 1.
33	20	Through the vehicle left side tiedown point # 1.
34	20A	Through the vehicle right side tiedown point # 1.
35	21	Through the vehicle left side outer lifting point.
36	21A	Through the vehicle right side outer lifting point.

Figure 4-18. Truck positioned and lashed to the platform (Continued)

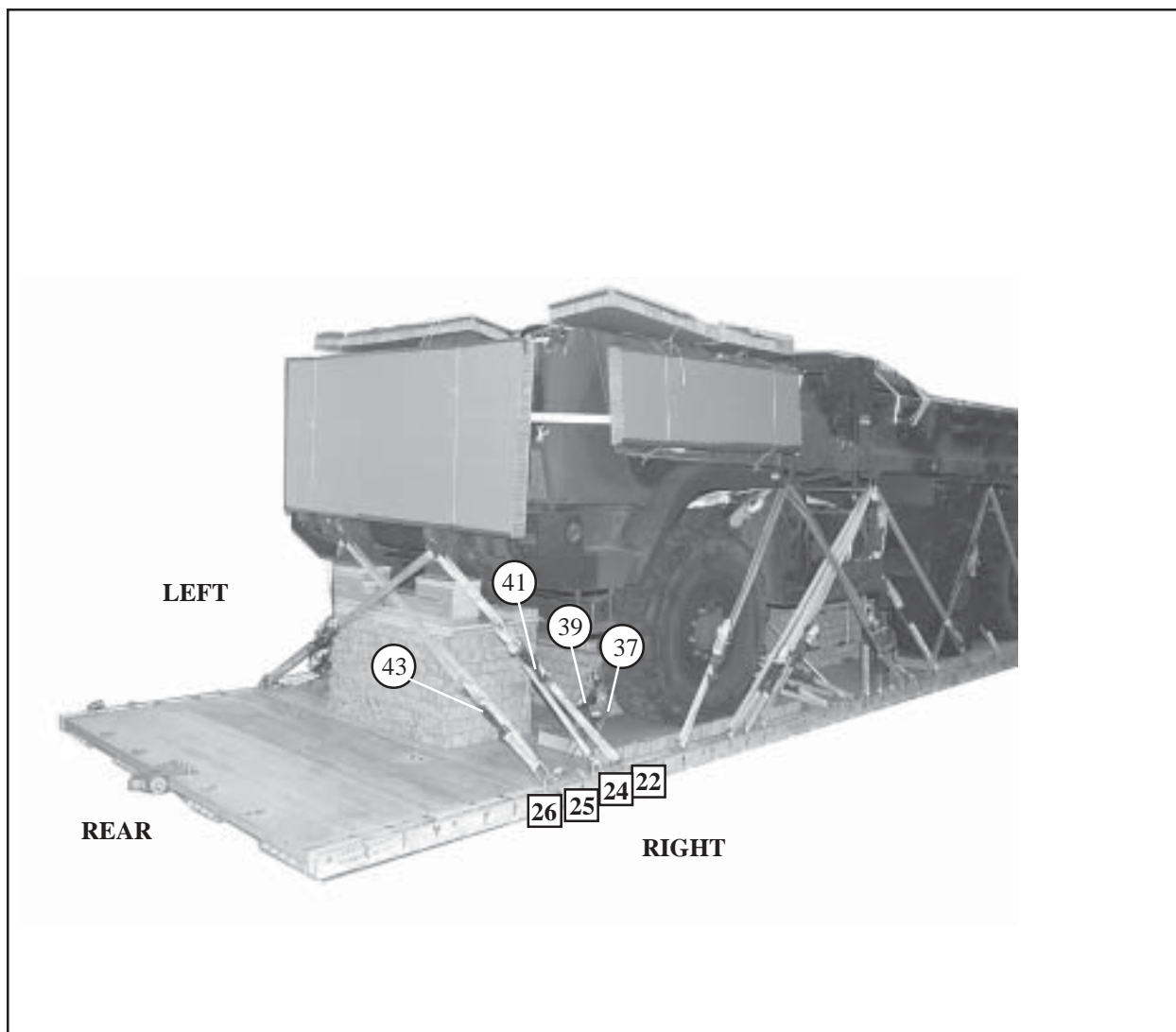

Lashing Number	Tiedown Clevis Number	Instructions
37	24	Pass lashing: Around the vehicle left side front axle, underneath all hoses.
38	24A	Around the vehicle right side front axle, underneath all hoses.
39	25	Around the vehicle left side front axle, underneath all hoses.
40	25A	Around the vehicle right side front axle, underneath all hoses.
41	22	Through vehicle front tiedown shackle, left side.
42	22A	Through vehicle front tiedown shackle, right side.
43	26	Through vehicle front tiedown shackle, right side.
44	26A	Through vehicle front tiedown shackle, left side.

Figure 4-18. Truck positioned and lashed to the platform (Continued)

4-9. Installing and Safetying Suspension Slings

Install and safety the slings according to FM 4-20.102/NAVSEA SS400-AB-MMO-101/TO 13C7-1-5 and as shown in *Figure 4-19*.

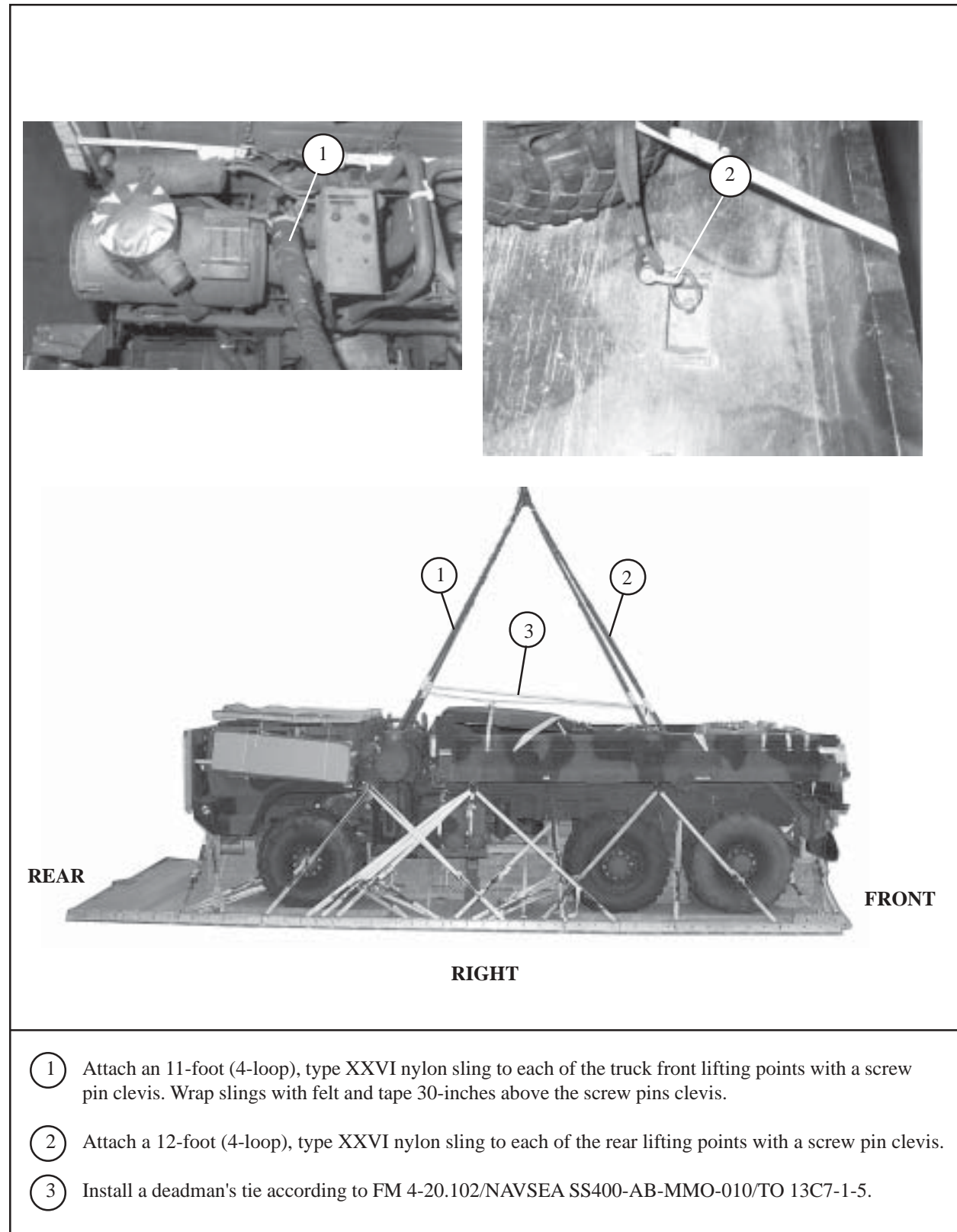

Figure 4-19. Suspension slings installed and safetyed

4-10. Building and Positioning the Parachute Stowage Platform

Build and position the parachute stowage platform as shown in *Figure 4-20*.

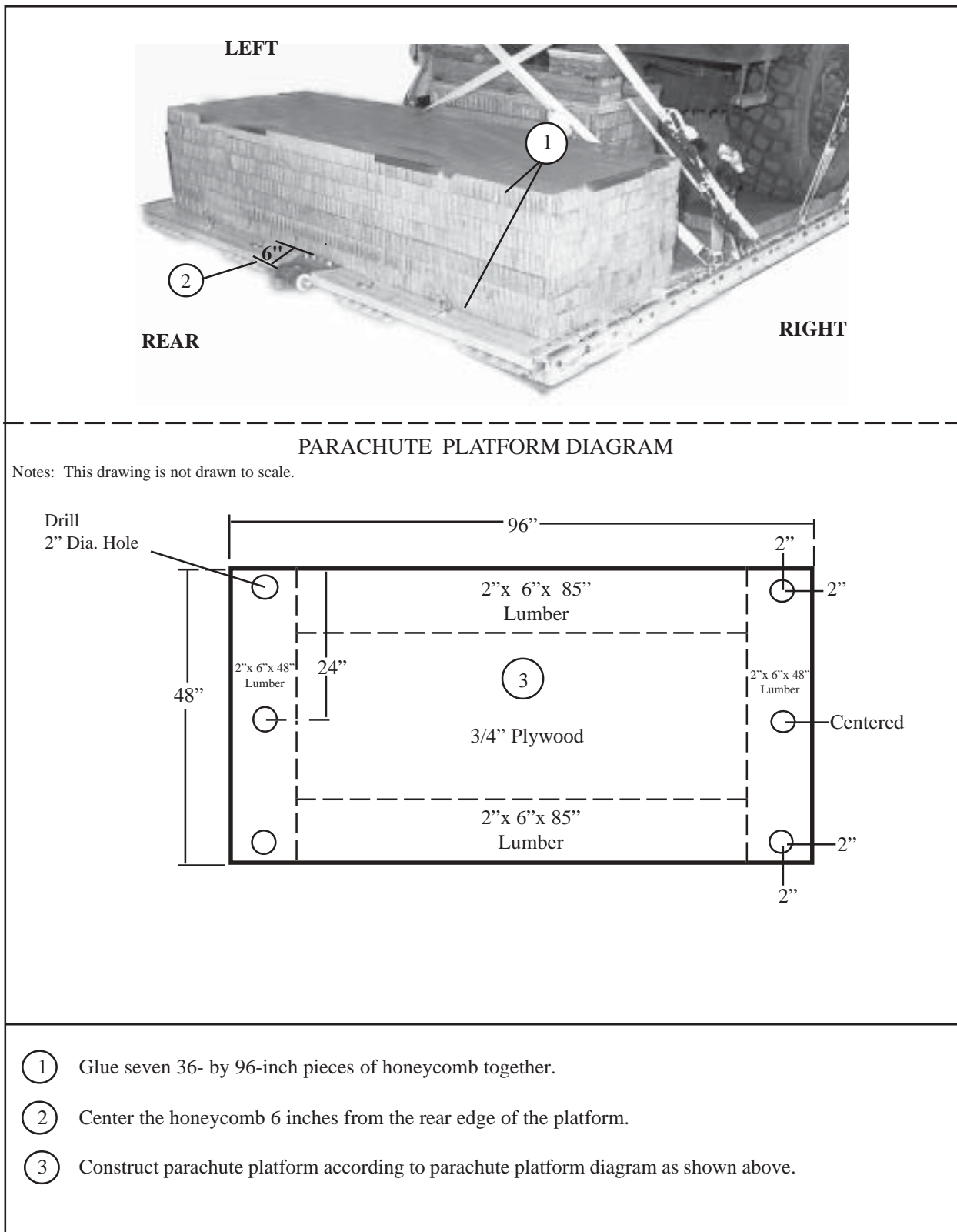
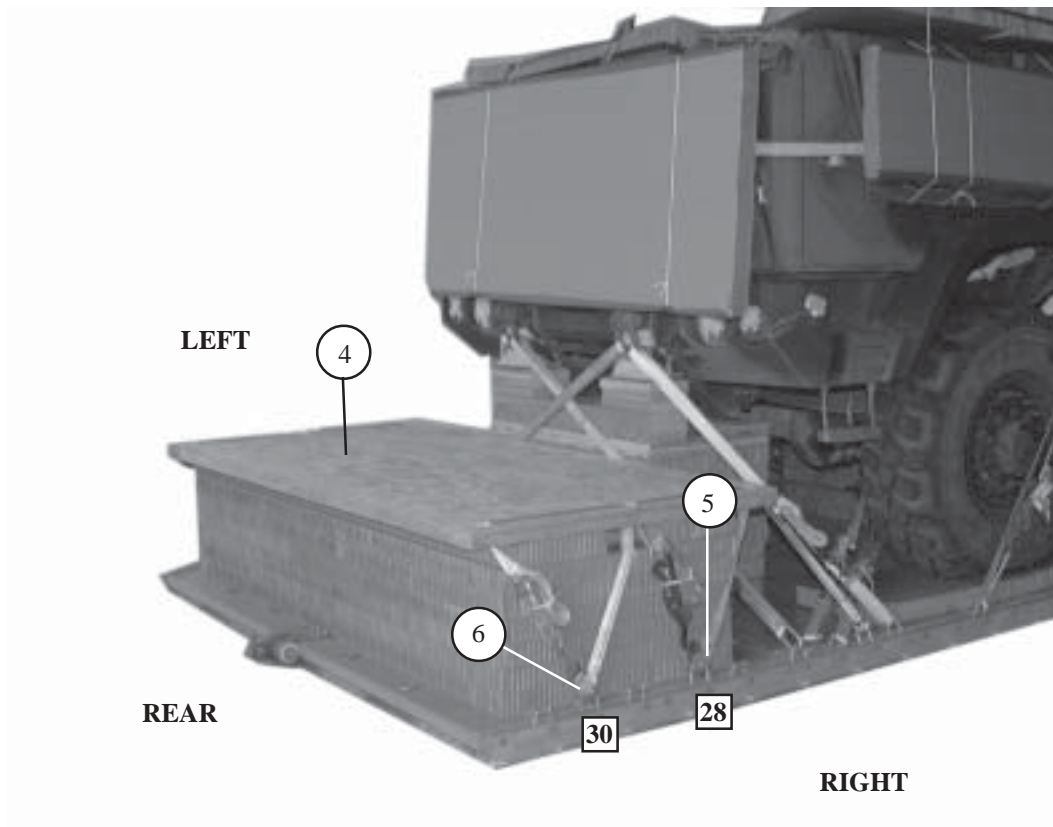

Figure 4-20. Parachute stowage platform positioned



- ④ Position the parachute platform on the honeycomb stack.
- ⑤ Route a lashing from clevis 28 through the parachute platform front, holes through the center holes and secure with a loadbinder. Repeat using clevis 28A for the left side.
- ⑥ Route a lashing from clevis 30 through the parachute platform center holes, through the rear holes and secure with a loadbinder. Repeat using clevis 30A for the left side.

Figure 4-20. Parachute stowage platform positioned (Continued)

4-11. Stowing Cargo Parachutes

Stow seven G-11C cargo parachutes as shown in *Figure 4-21*.

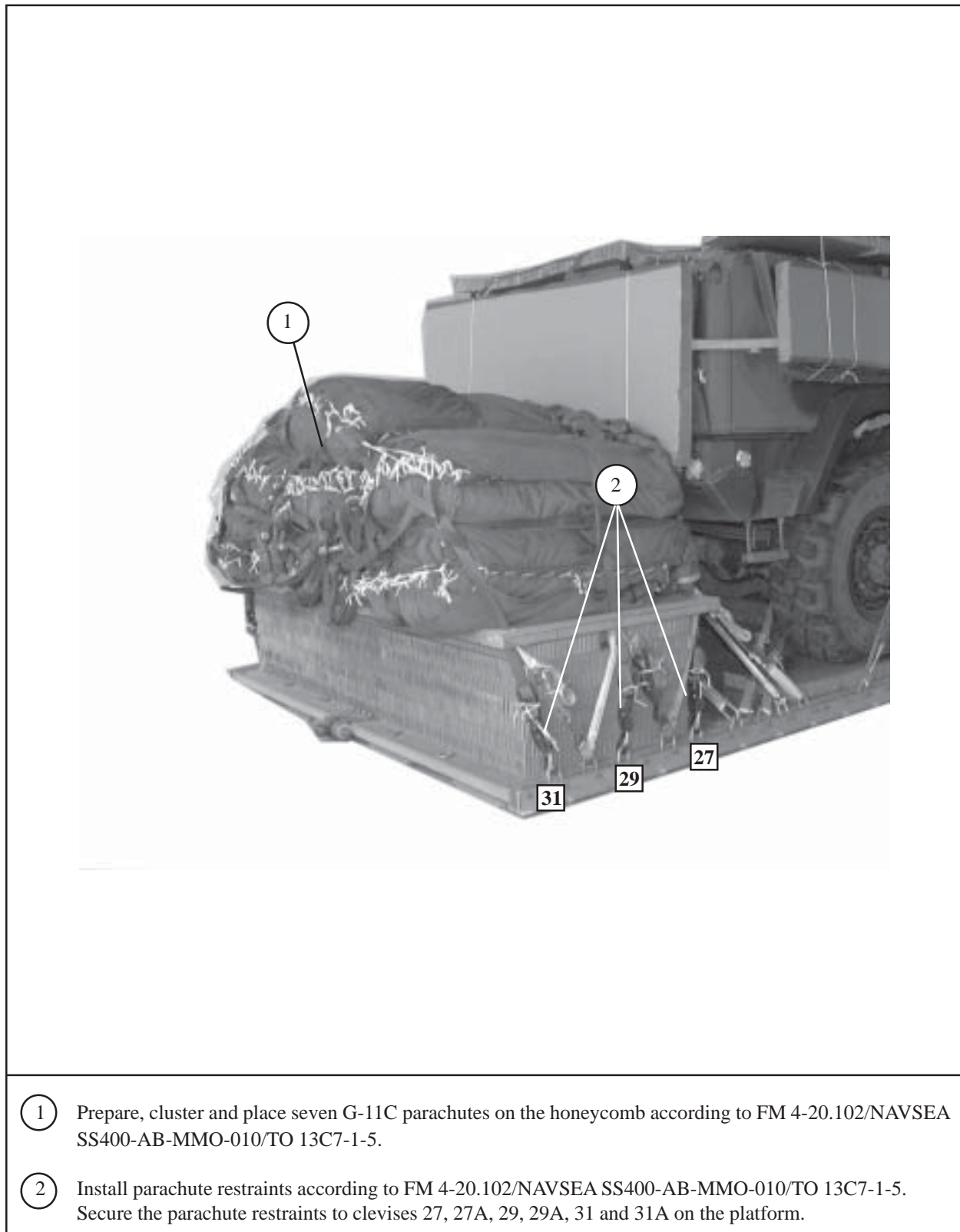
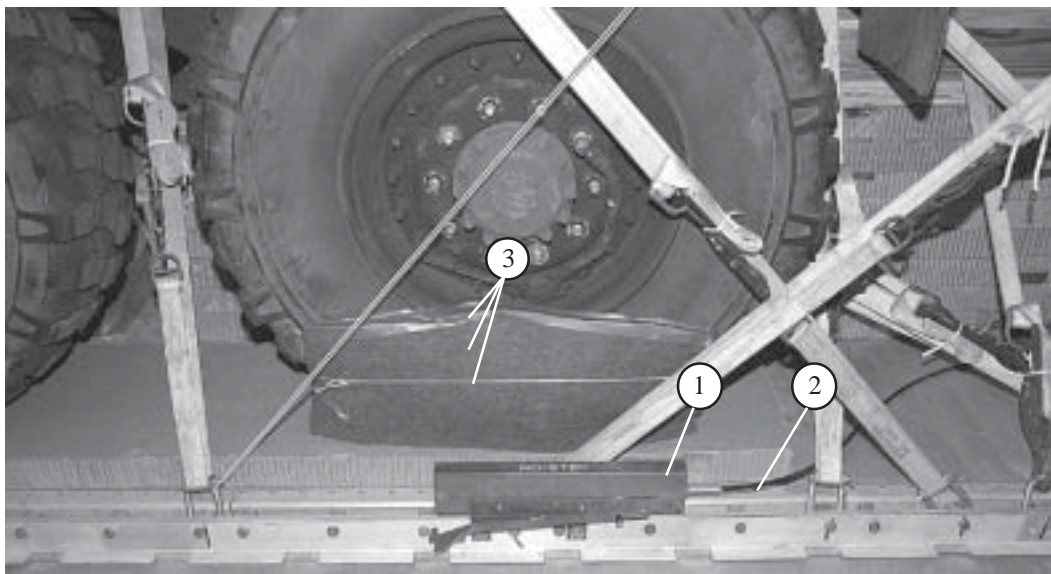

Figure 4-21. Parachutes stowed

4-12. Installing Extraction System

Install the components of the extraction force transfer coupling (EFTC) according to FM 4-20.102/NAVSEA SS400-AB-MMO-010/TO 13C7-1-5 and as shown in *Figure 4-22*.



- ① Install the EFTC mounting brackets in the front mounting holes on the left platform rail.

Note: When using older type V rails that have three mounting positions for mounting the EFTC bracket, use the center position. When using the new rails with two mounting positions, use the forward position.

- ② Install the EFTC extraction system according to FM 4-20.102/NAVSEA SS400-AB-MMO-010/TO 13C7-1-5. Attach a 24-foot release cable to the actuator mounting brackets.
- ③ Secure a 10- by 22-inch piece of 1/2-inch felt to the tire with type III nylon cord and 2-inch adhesive tape located next to the actuator assembly.

Figure 4-22. Extraction system installed

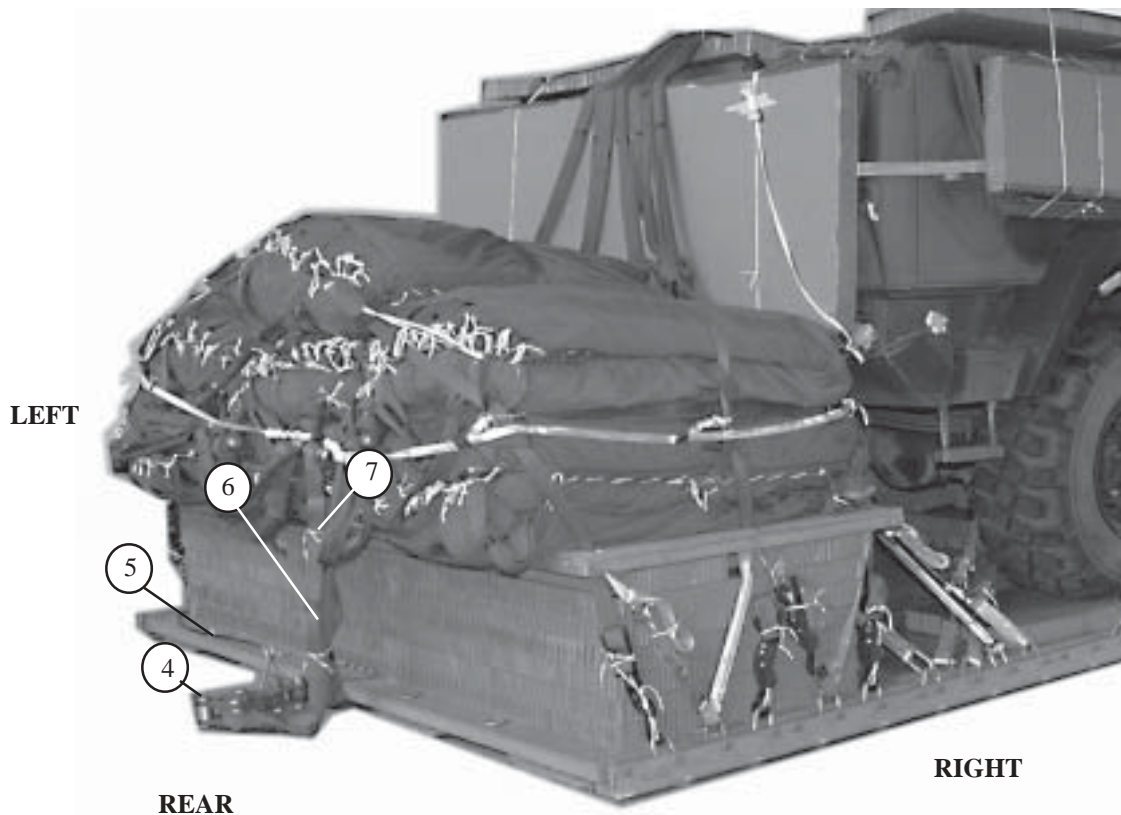

- ④ Install the latch assembly on the extraction bracket according to FM 4-20.102/NAVSEA SS400-AB-MMO-101/TO 13C7-1-5. Attach the release cable to the latch assembly.
- ⑤ Safety the cable with one turn type I, 1/4-inch cotton webbing to the platform bushings or deck rings.
- ⑥ Attach a 9-foot (2-loop), type XXVI nylon sling to be used as a deployment line according to FM 4-20.102/NAVSEA SS400-AB-MMO-010/TO 13C7-1-5. Attach the other end to the three point link.
- ⑦ Fold the excess deployment line, and secure the folds with type I, 1/4-inch cotton webbing according to FM 4-20.102/NAVSEA SS400-AB-MMO-010/TO 13C7-1-5.

Figure 4-22. Extraction system installed (Continued)

4-13. Installing Release System

Install an M-2 cargo parachute release according to FM 4-20.102/NAVSEA SS400-AB-MMO-010/TO 13C7-1-5 and as shown in *Figure 4-23*.

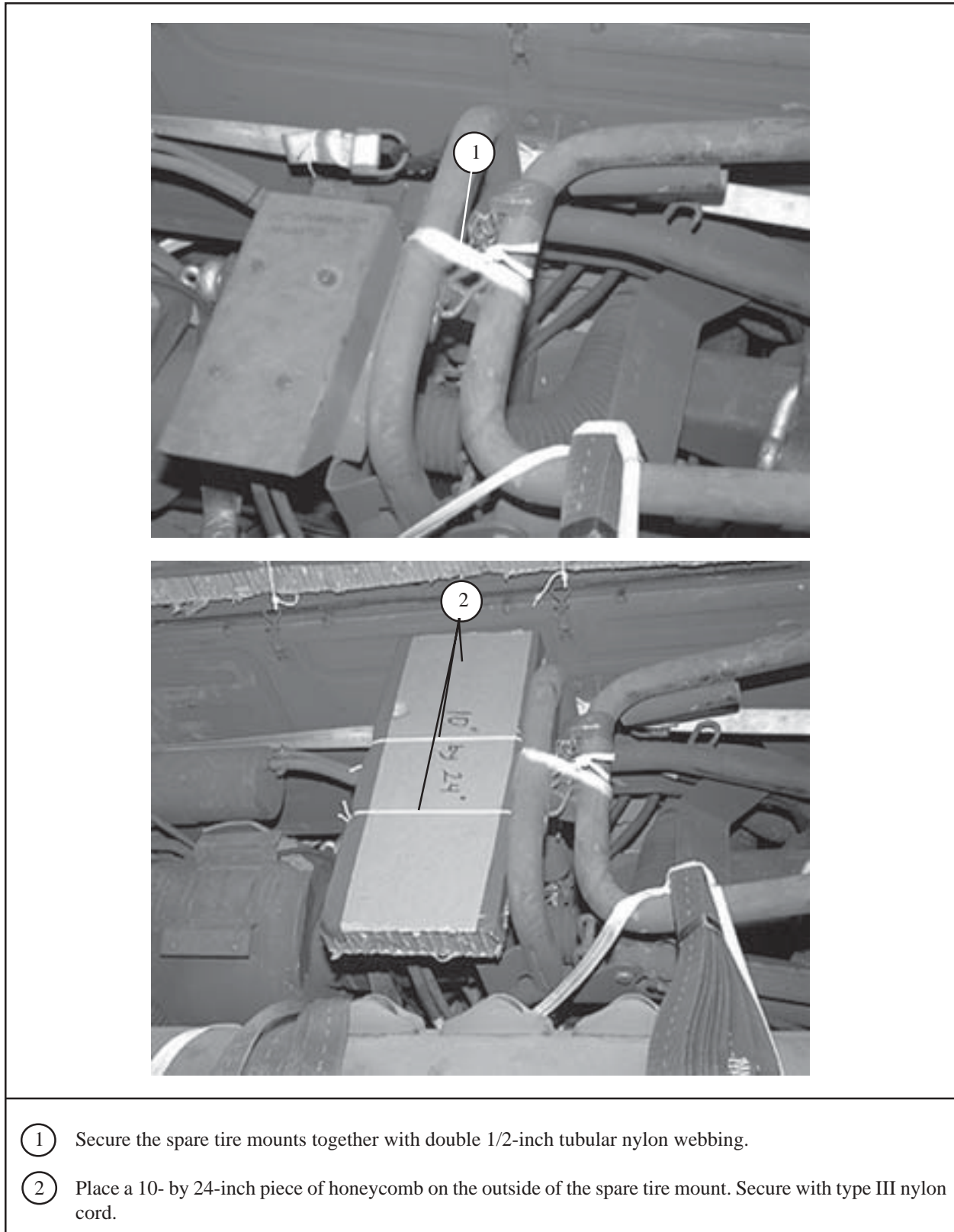
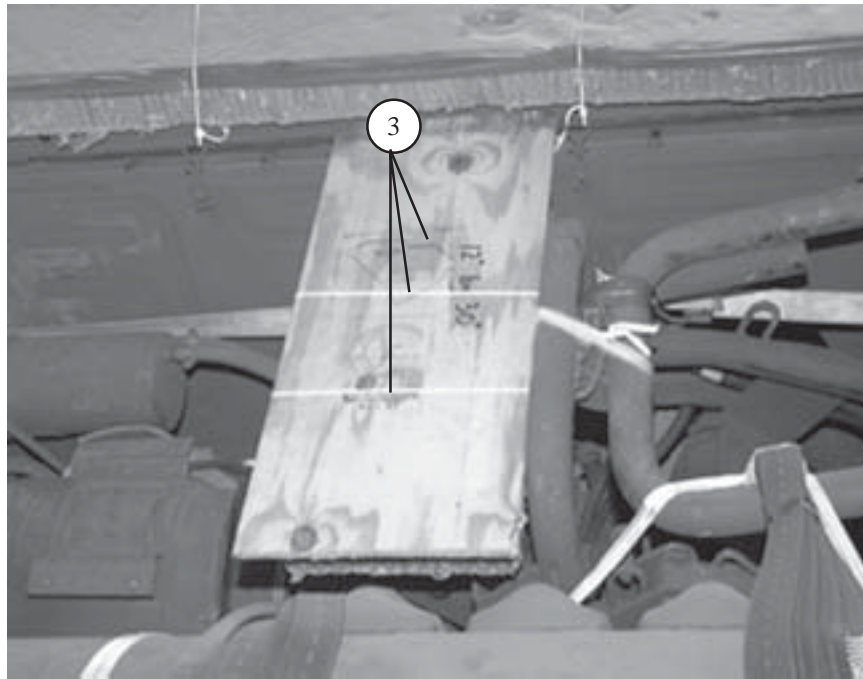
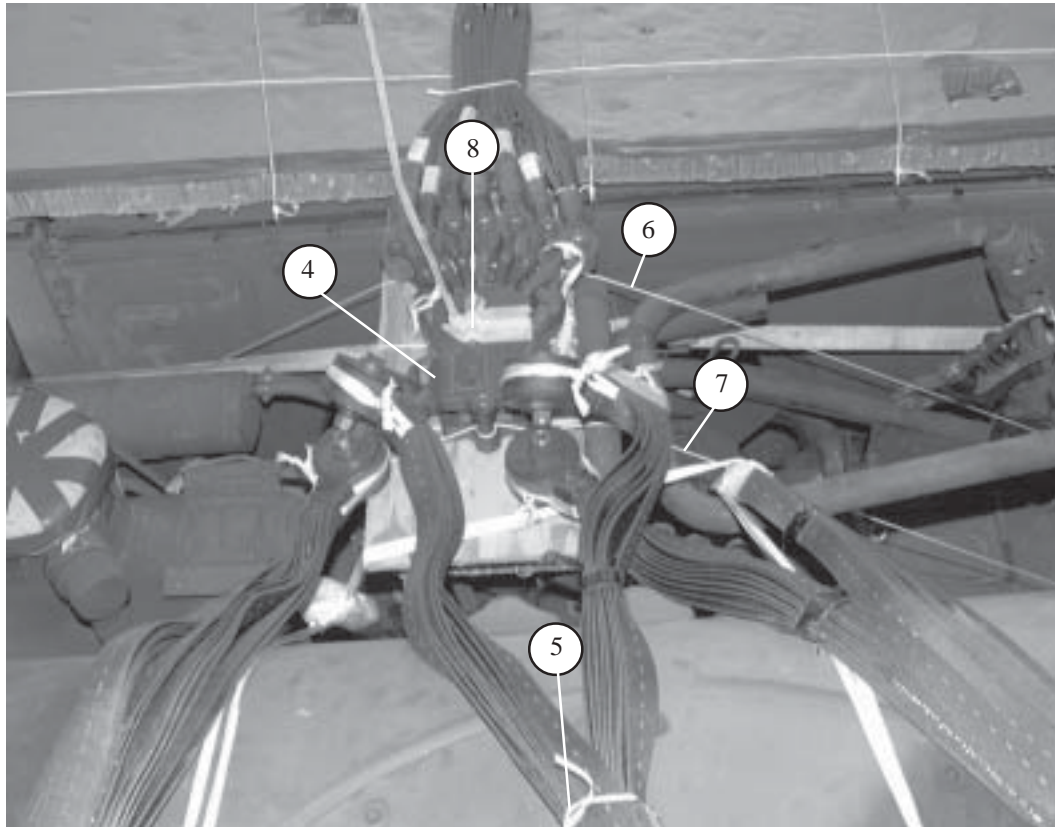

Figure 4-23. Parachute release installed



- ③ Place a 12- by 30-inch piece of 1/4-inch plywood centered on top of the piece of honeycomb. Secure it in place with type III nylon cord.

Figure 4-23. Parachute release installed (Continued)



- ④ Prepare an M-2 cargo parachute release assembly according to FM 4-20.102/NAVSEA SS400-AB-MMO-010/TO 13C7-1-5. Attach the release assembly to the suspension slings and the cargo parachutes according to FM 4-20.102/NAVSEA SS400-AB-MMO-010/TO 13C7-1-5. Center the release assembly on top of the plywood.
- ⑤ Fold the suspension slings, and secure the folds with single turns of type I, 1/4-inch cotton webbing.
- ⑥ Secure the top of the release assembly to convenient places on the load and according to FM 4-20.102/NAVSEA SS400-AB-MMO-010/TO 13C7-1-5.
- ⑦ Secure the bottom of the release assembly to convenient places on the load and according to FM 4-20.102/NAVSEA SS400-AB-MMO-010/TO 13C7-1-5. Fold and tie any slack in the suspension slings.
- ⑧ Install the arming lanyard according to FM 4-20.102/NAVSEA SS400-AB-MMO-010/TO 13C7-1-5.

Figure 4-23. Parachute release installed (Continued)

4-14. Installing Provisions for Emergency Restraints

Select and install provisions for emergency restraints according to the emergency restraint requirements table found in FM 4-20.102/NAVSEA SS400-AB-MMO-010/TO 13C7-1-5.

4-15. Placing Extraction Parachute

Select the extraction parachute and extraction parachute line needed using the extraction parachute and extraction line requirements table found in FM 4-20.102/NAVSEA SS400-AB-MMO-010/TO 13C7-1-5.

4-16. Marking the Rigged Load

Mark the rigged load according to FM 4-20.102/NAVSEA SS400-AB-MMO-010/TO 13C7-1-5 and as shown in *Figure 4-24*.

4-17. Equipment Required

Use the equipment listed in *Table 4-2* to rig this load.

CAUTION
 Make the final rigger inspection required by
 FM 4-20.102/NAVSEA SS400-AB-MMO-010/TO 13C7-1-5 before the load
 leaves the rigging site.

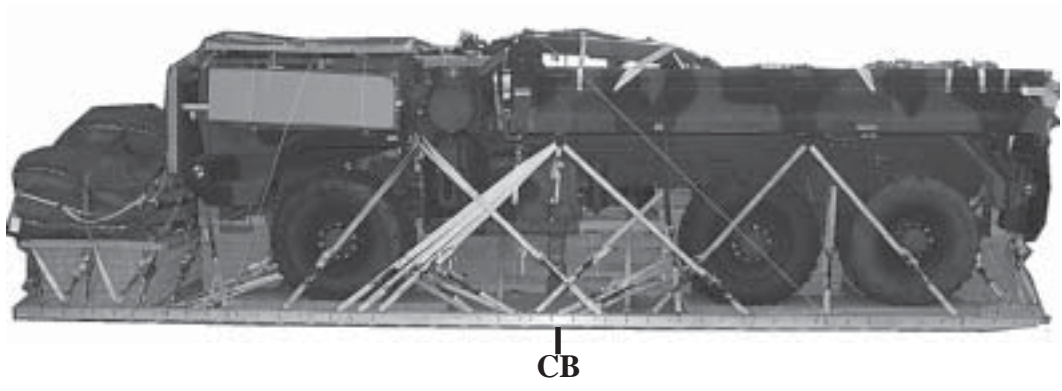

CAUTION
 This load requires a ballast box of a minimum of 2,000 pounds
 and a of maximum 2,200 pounds to attain the required Center of
 Balance (CB).

RIGGED LOAD DATA

Weight: Load shown	34, 100 pounds
Maximum load allowed	34, 600 pounds
Height	95 inches
Width	108 inches
Overall-Length	354 inches
Overhang: Front	6 1/2 inches
Rear (EFTC)	18 inches
CB (from front edge of platform)	144 inches
Extraction System	EFTC

Figure 4-24. M1094, 5-ton dump truck rigged for low-velocity airdrop

Table 4-2. Equipment required for rigging the M1094, 5-ton dump truck for low-velocity airdrop on type V platform

National Stock Number	Item	Quantity
8040-00-273-8713	Adhesive, paste, 1-gal	As required
N/A	Bolt, (washers and nuts) 1/2- by 10-in	4
1670-01-035-6054	Bridle, extraction line bag (Use with extraction line bag)	2
4030-00-432-2516	Clevis, screw pin	4
4030-00-090-5354	Clevis, suspension, 1-in (large)	9
4030-00-678-8562	Clevis, medium	2
4020-00-240-2146	Cord, nylon, type III, (550-lb)	As required
1670-00-157-6527	Coupling assembly, airdrop, extraction force transfer w/cable, 28-ft	1
1670-00-360-0328	Cover, clevis, large	8
8135-00-664-6958	Cushioning material, packaging, (cellulose wadding)	As required
8305-00-958-3685	Felt, 1/2-in thick	As required
1670-01-003-4391	Knife, parachute bag	1
1670-01-183-2678	Leaf, extraction line (line bag)	2
1670-01-064-6312	Line, drogue 60-foot (1-loop), type XXVI	1
1670-01-064-4454	Line, extraction, type XXVI nylon webbing: 60-ft (6-loop), (C-130 aircraft)	1
1670-01-062-6312	120-ft (6-loop), (C-141 aircraft)	2
1670-01-062-6312	120-ft (6-loop), (C-5 aircraft) (between fuselage station 1667-1971)	1
1670-01-062-6312	120-ft (6-loop), <i>and a</i>	1
1670-01-064-4454	60-ft (6-loop), (C-5 aircraft) (between fuselage station 947-1666)	1
1670-01-062-6312	120-ft (6-loop), (C-5 aircraft) (between fuselage station 574-947)	1
1670-01-468-9178	140-ft (6-loop), (C-17 aircraft)	2

Table 4-2. Equipment required for rigging the M1094, 5-ton dump truck for low-velocity airdrop on a type V platform (continued)

National Stock Number	Item	Quantity
	Link assembly:	
	Two-point:	
5306-00-435-8994	Bolts, 1-in diam, 4-in long	(4)
5310-00-232-5165	Nuts, 1-in, hexagonal	(4)
1670-00-003-1954	Plate, side, 5 1/2-in, arm, cargo extra	(4)
5365-00-007-3414	Spacers, large	(4)
1670-00-006-2752	Four-point	2
1670-01-483-8259	Link, towed mechanized release (H-Block) (C17 aircraft)	1
	Lumber:	
5510-00-220-6146	2- by 4-in	As required
5510-00-220-6148	2- by 6-in	As required
5510-00-220-6274	4- by 4-in	As required
	Nail, steel wire, common:	
5315-00010-4659	8d	As required
5315-00-010-4662	12d	As required
5315-00-753-3885	16d	As required
1670-00-753-3928	Pad, energy dissipating, honeycomb, 3- by 36- by 96-in	As required
	Parachute, cargo:	
1670-01-016-7841	G-11C	7
	Parachute, cargo extraction:	
1670-00-040-8135	28-ft	2
1670-01-063-3715	15-ft (C-17 only)	1
	Platform, airdrop, type V, 28-ft:	
1670-01-162-2372	Clevis, load tiedown (type V)	(66)
1670-01-162-2376	Extraction bracket assembly	(1)
1670-01-247-2389	Link, suspension bracket assembly, type V	(2)
1670-01-162-2381	Tandem link assembly (Multipurpose link)	(2)
	Plywood, construction:	
5530-00-128-5419	1/4-in	As required
5530-00-129-7777	1/2-in	As required
5530-00-128-4981	3/4-in:	As required
1670-01-097-8817	Release, cargo parachute, M-2	1

Table 4-2. Equipment required for rigging the M1094, 5-ton dump truck for low-velocity airdrop on a type V platform (continued)

National Stock Number	Item	Quantity
	Sling, cargo, airdrop:	
	For deployment line:	
1670-01-062-6304	9-ft (2-loop), type XXVI nylon webbing	1
	For lifting:	
1670-01-062-6305	9-ft (4-loop), type XXVI nylon webbing	2
1670-01-064-4453	20-ft (4-loop), type XXVI nylon webbing	1
	For suspension:	
1670-01-062-6310	11-ft (4-loop), type XXVI nylon webbing	2
1670-01-062-6307	12-ft (4-loop), type XXVI nylon webbing	2
	For riser extension:	
1670-01-062-6311	120-ft (2-loop), type XXVI nylon webbing	7
5340-00-040-8219	Strap, parachute release, multi-cut with 3 knives	2
7510-00-266-5016	Tape, adhesive, 2-in (masking)	As required
7510-00-074-5124	Tape, type IV, cloth-back, adhesive sensitive, 2-in	As required
1670-00-937-0271	Tiedown assembly, 15-ft	80
	Webbing:	
8305-00-268-2411	Cotton, type I, 1/4-in, 80-lb	As required
8305-00-082-5752	Nylon, tubular, 1/2-in, 1,000-lb, natural	As required
8305-00-268-2455	Nylon, tubular, 1-in, 4,000-lb, natural	As required
8305-00-260-6890	Nylon, type X	As required

CHAPTER 5

RIGGING THE M1095, 5-TON TRAILER ON A 24-FOOT TYPE V PLATFORM

5-1. Description of Load

The M1095, 5-ton trailer (*Figure 5-1*), and accompanying load is rigged on a 24-foot, type V airdrop platform with six G-11C cargo parachutes and other items of airdrop equipment.

The load consists of the M1095, 5-ton trailer and accompanying load. This load is 99 1/2 inches in height, 108 inches in width, 306 inches in overall length and has a rigged weight of 30,330 pounds.



Figure 5-1. M1095, 5-ton trailer

5-2. Preparing Platform

Prepare a 24-foot, type V platform as described below and as shown in *Figure 5-2*.

Notes:

1. Measurements given in this section are from the front edge of the platform.
2. The "triple" clevis installations provide two tiedown points for the same attachment hole.

Step:

1. Inspect, or assemble and inspect, a 24-foot, type V airdrop platform as outlined in TM 10-1670-268-20&P/TO 13C7-52-22.
2. Install a tandem link on the front of each platform side rail using holes 1, 2, and 3.
3. Install a suspension bracket assembly to each platform side rail using holes 5, 6, and 7.
4. Install a suspension bracket assembly to each platform side rail using holes 18, 19, and 20.
5. Install a suspension bracket assembly to each platform side rail using holes 29, 30, and 31.
6. Install a suspension bracket assembly to each platform side rail using holes 41, 42, and 43.
7. Attach a clevis on bushings 1, 2, 3 and 4 of each of the front tandem links.
8. Attach a clevis on bushings 1, 3 and 4 (tripled) of each of the first suspension bracket assembly.
9. Attach a clevis on bushing 4 of each of the second suspension bracket assembly.
10. Attach a clevis on bushings 1, 3 (tripled) and 4 (doubled) of each of the fourth suspension bracket assembly.
11. Starting at the front of each platform side rail, install clevises using bushings bolted to holes 4, 9 (tripled), 10, 11, 15, 25, 26, 28, 34, 35, 36, 39, 40 (tripled), 45, 46 (tripled), 47 (tripled), and 48 (tripled).
12. Starting at the front of the platform, number the clevises bolted to the right rail 1 through 35 and the left rail 1A through 35A.
13. Label the tiedown rings according to FM 4-20.102/NAVSEA SS400-AB-MMO-010/TO 13C7-1-5.

Figure 5-2. Platform prepared

5-3. Stowing Accompanying Load on Platform

Stow the accompanying load on the platform which consists of 16 green bag canisters, eight white bag canisters, five fuse ammo boxes, four M483 HE (high explosive) round racks and one M110A1 WP (white phosphorous) round rack of ammunition as shown in *Figure 5-3*.

CAUTION
Only ammunition listed in FM 10-500-53/MCRP 4-3.8/TO 13C7-18-41
may be airdropped. Package, mark, and label hazardous material according to AFMAN(I) 24-204/TM 38-250.

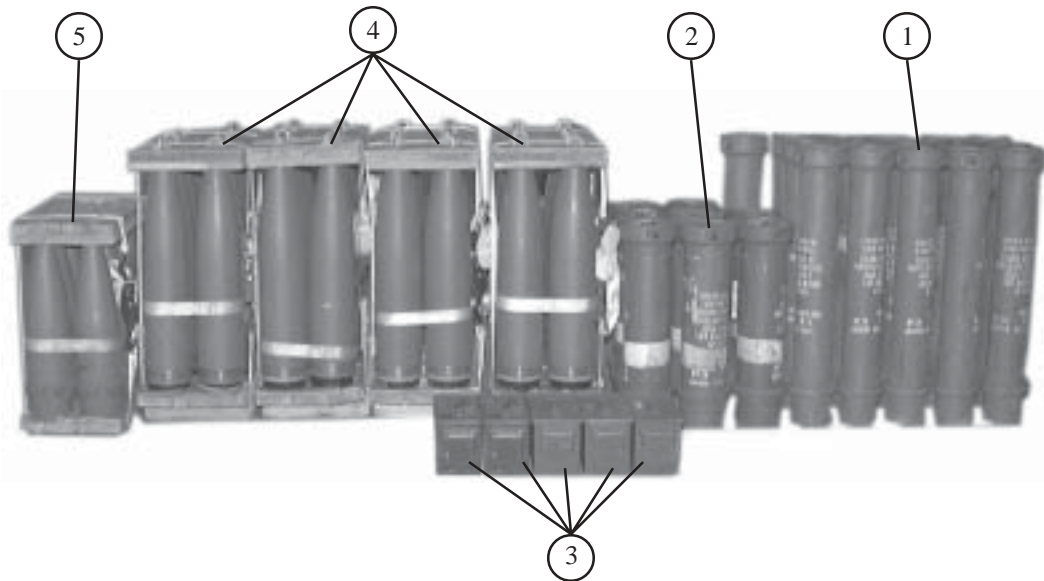

- ① Sixteen green bag canisters (large).
- ② Eight white bag canisters (small).
- ③ Five fuse ammo boxes.
- ④ Four M483 HE round racks.
- ⑤ One M110A1 WP round rack.

Figure 5-3. Accompanying load on the platform prepared

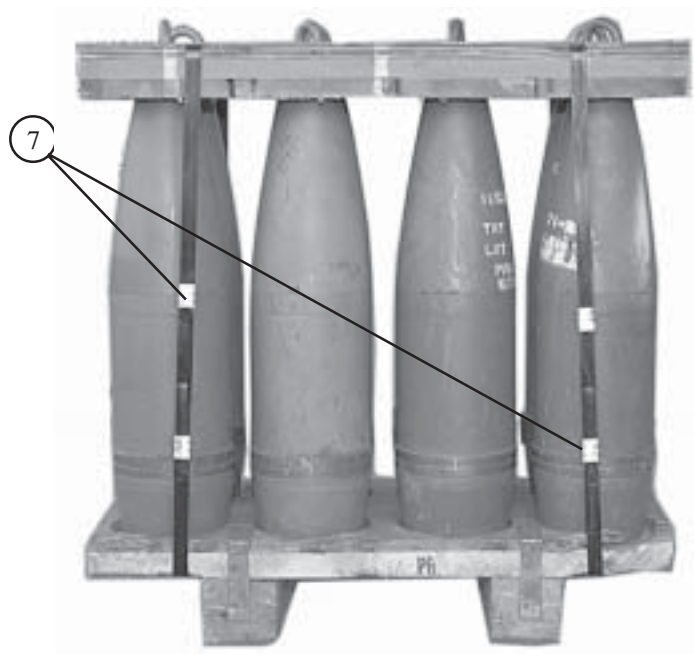
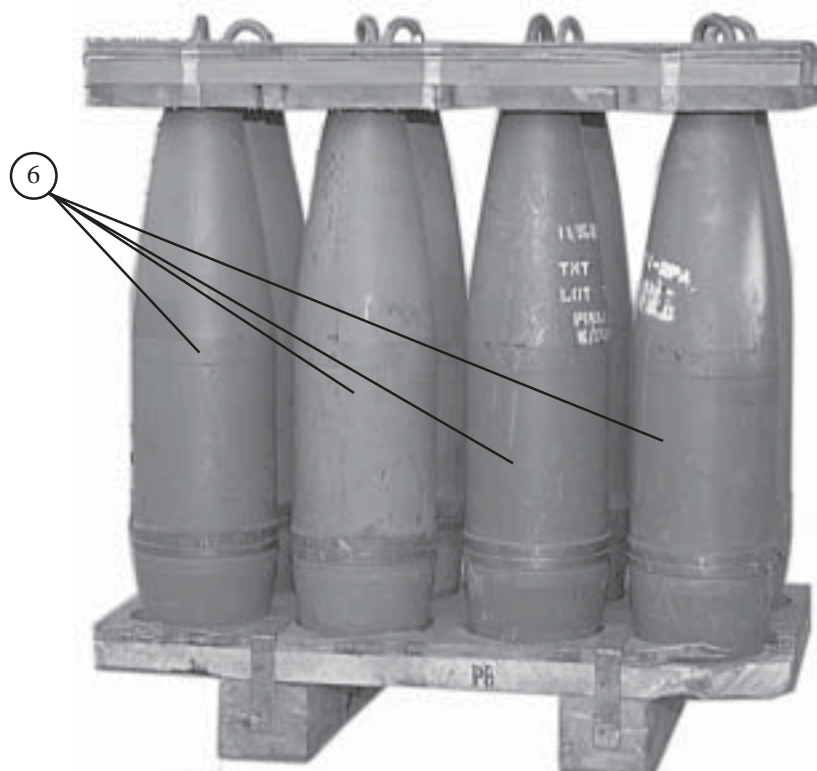

- ⑥ Place eight M110A1 White Phosphorus (WP) rounds in one wooden shipping rack with footers removed.
- ⑦ If the banding is on the M110A1 WP rounds wooden shipping rack, it may be left on. However it is not needed for rigging.

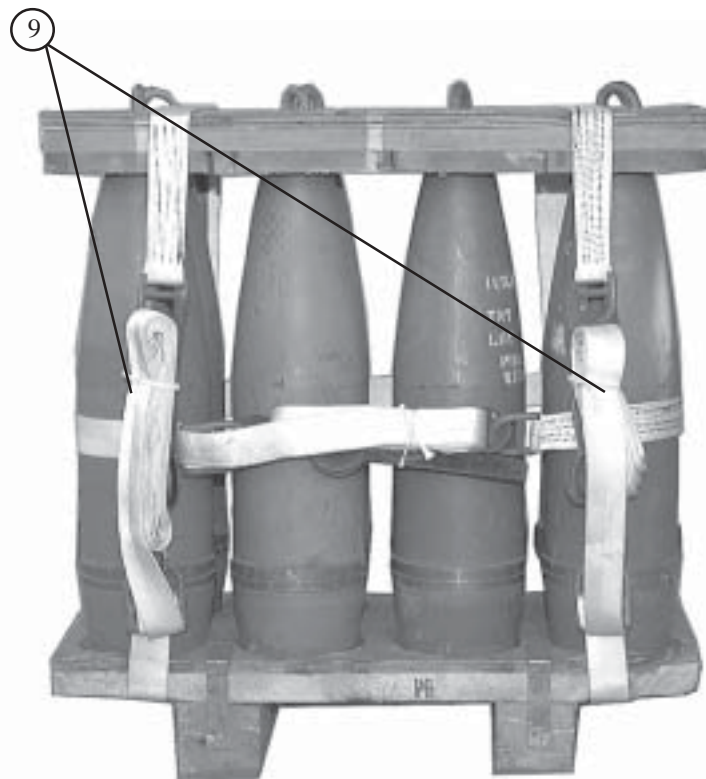
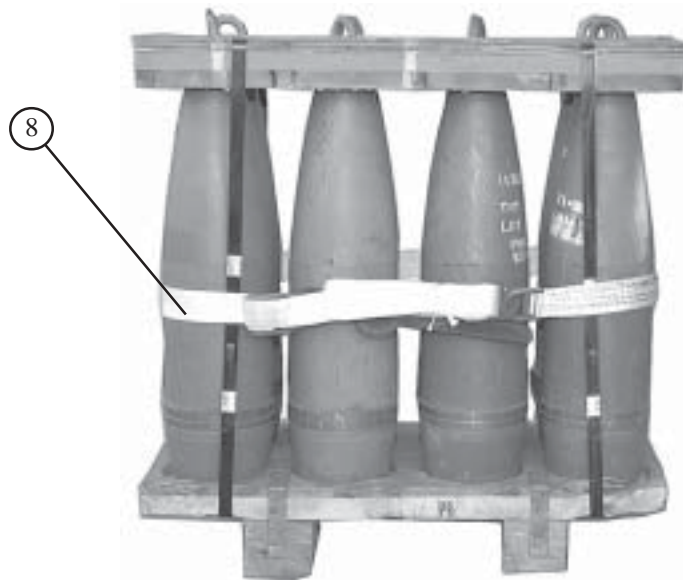

- ⑧ Route and secure a 15-foot lashing around the eight rounds.
- ⑨ Route and secure two 15-foot lashings vertically around the eight rounds.

Figure 5-3. Accompanying load on the platform prepared (Continued)

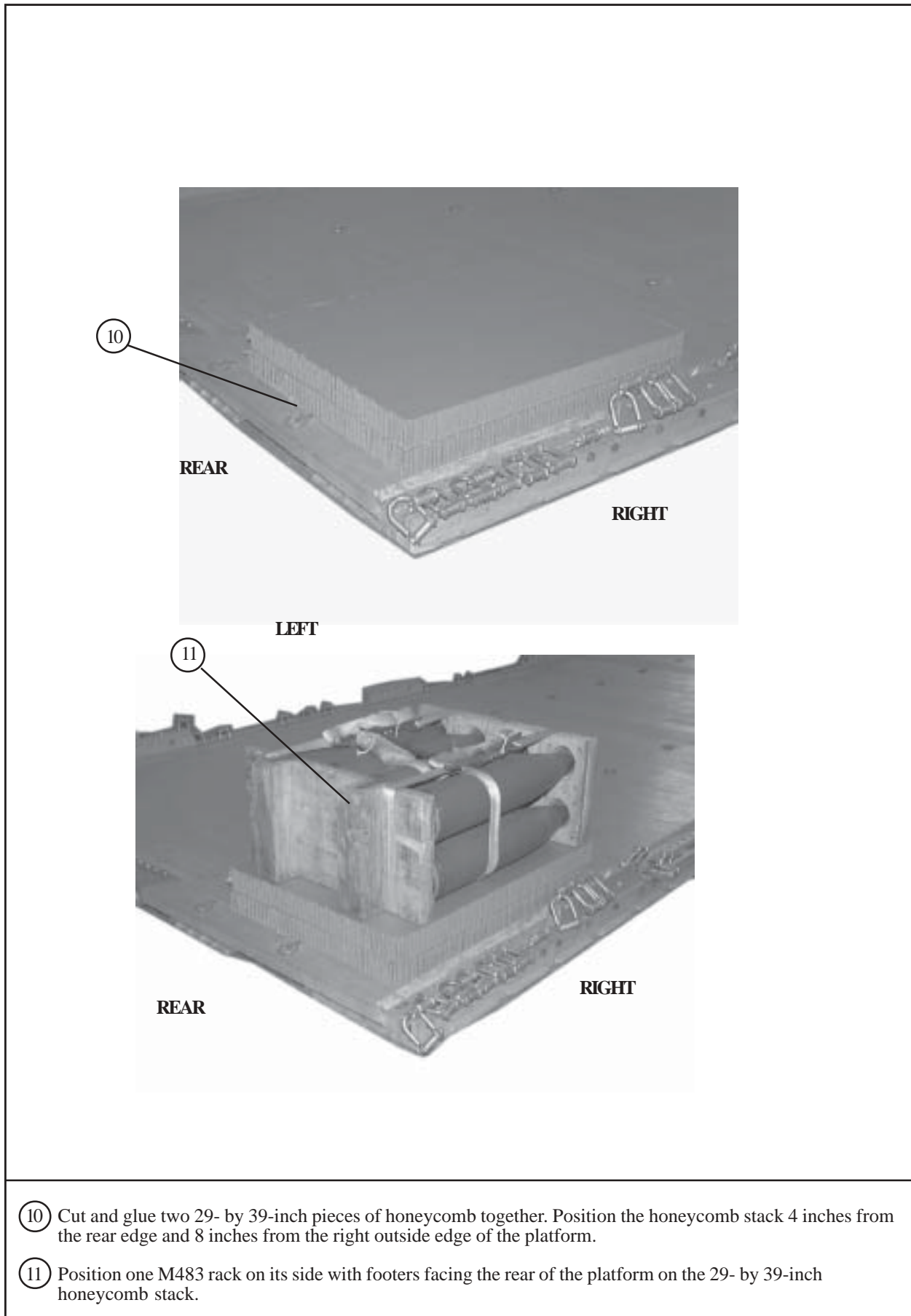

- ⑩ Cut and glue two 29- by 39-inch pieces of honeycomb together. Position the honeycomb stack 4 inches from the rear edge and 8 inches from the right outside edge of the platform.
- ⑪ Position one M483 rack on its side with footers facing the rear of the platform on the 29- by 39-inch honeycomb stack.

- Note:** 1. This drawing is not drawn to scale.
2. All measurements are given in inches.

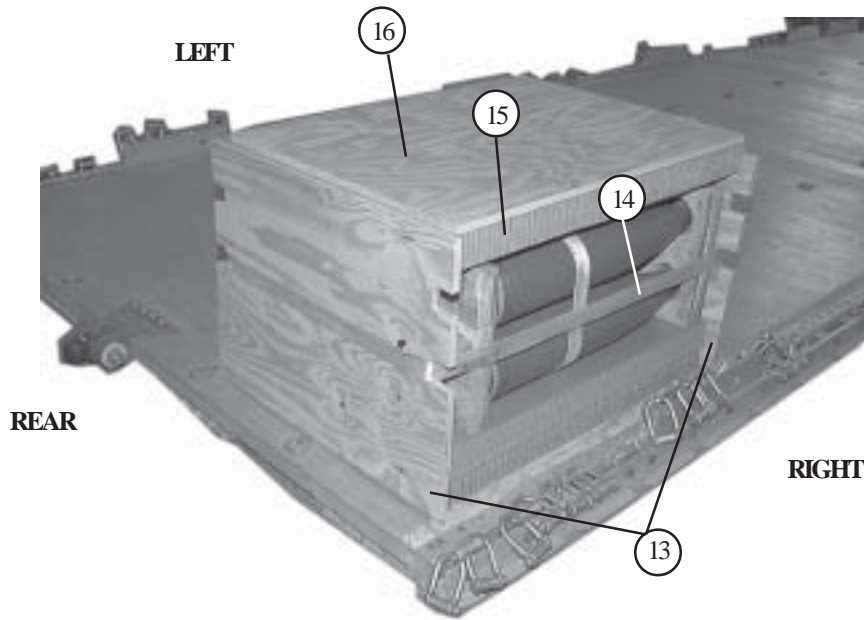
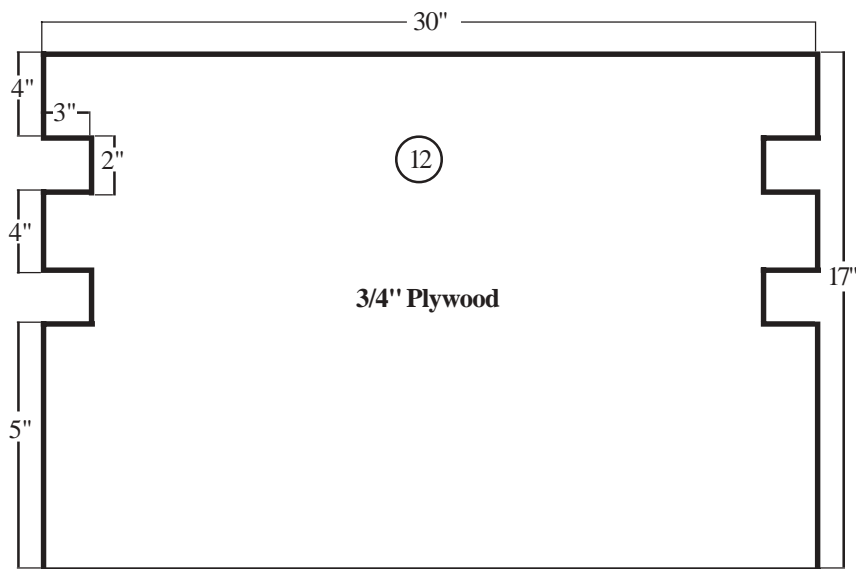

- (12) Construct four endboards as shown in diagram above with 2- by 3-inch deep cutouts.
- (13) Place an endboard at the front and rear of the M483 rack.
- (14) Route a lashing around the rack and through the lower cutouts of the endboard. Secure with a loadbinder on the left side.
- (15) Place a 29- by 39-inch piece of honeycomb on top of the rack.
- (16) Place a 29- by 39- by 3/4-inch piece of plywood on top of the 29- by 39-inch piece of honeycomb.

Figure 5-3. Accompanying load on the platform prepared (Continued)

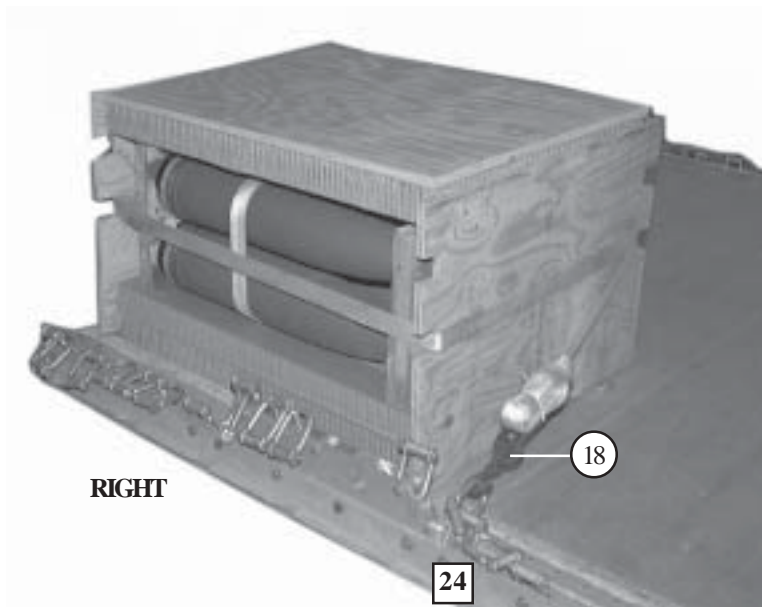
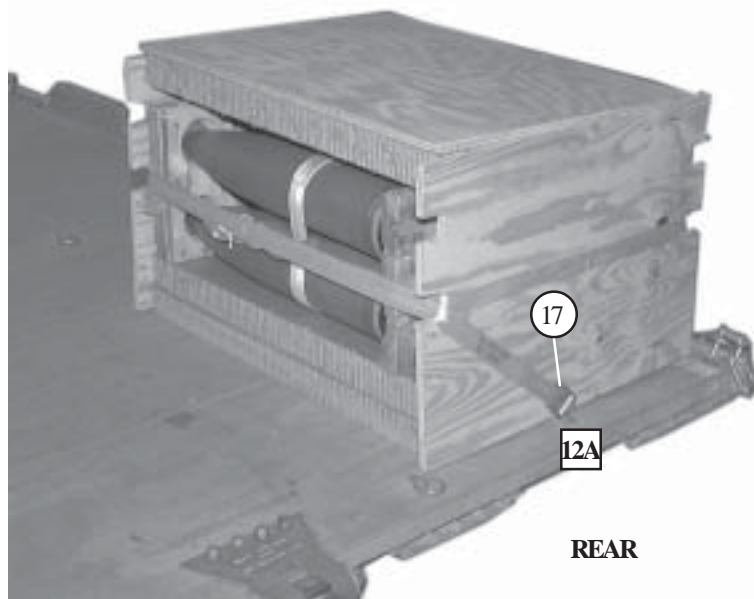

- ①7 Route a lashing through tiedown deck-ring 12A and through its own D-ring and through the lower left cutouts.
- ①8 Secure with a loadbinder to clevis 24.

Figure 5-3. Accompanying load on the platform prepared (Continued)

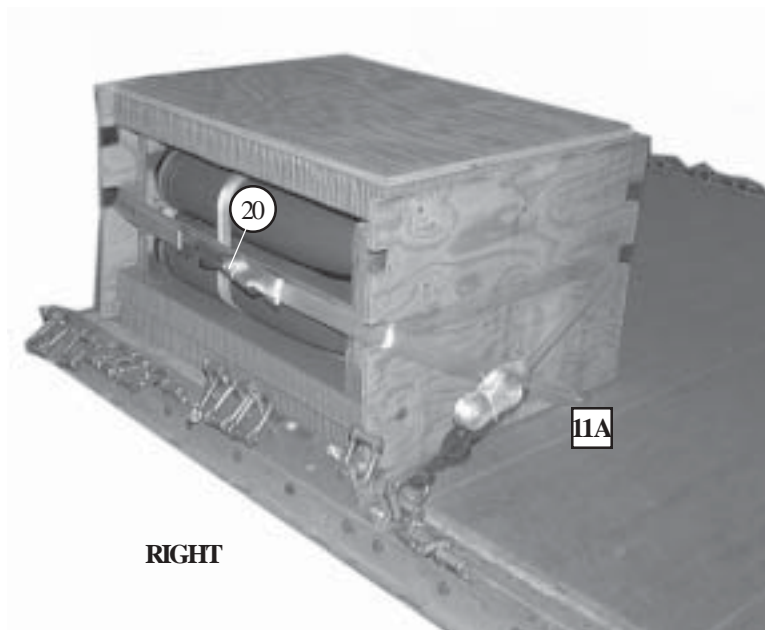
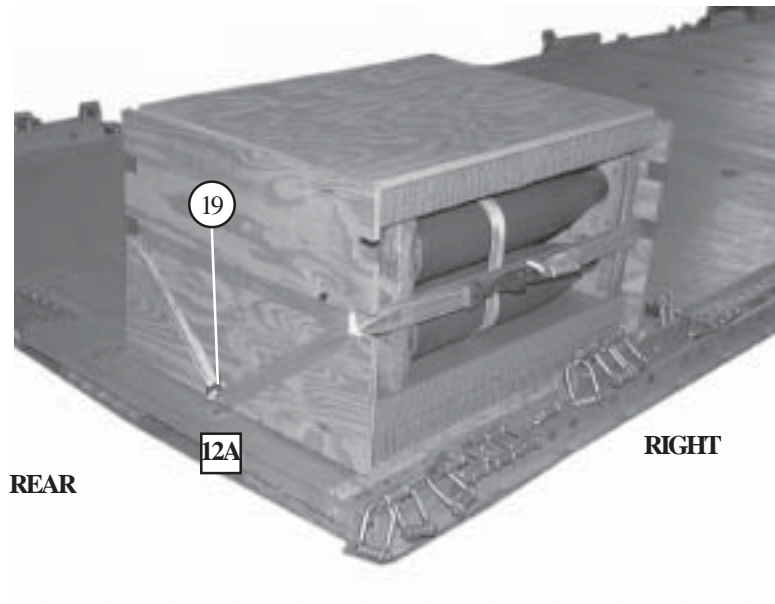

- ①9 Route a lashing through tiedown-ring 12A through the rear lower right cutouts and through the front lower right cutout through tiedown ring 11A.
- ②0 Secure with a loadbinder on right side.

Figure 5-3. Accompanying load on the platform prepared (Continued)

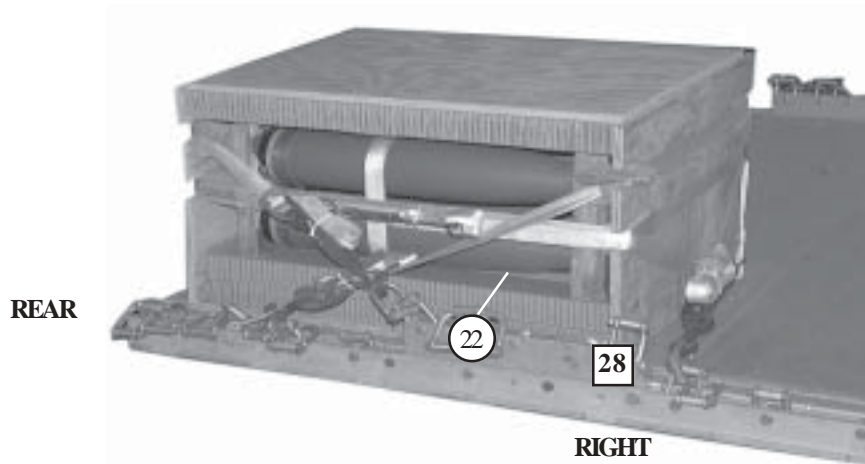
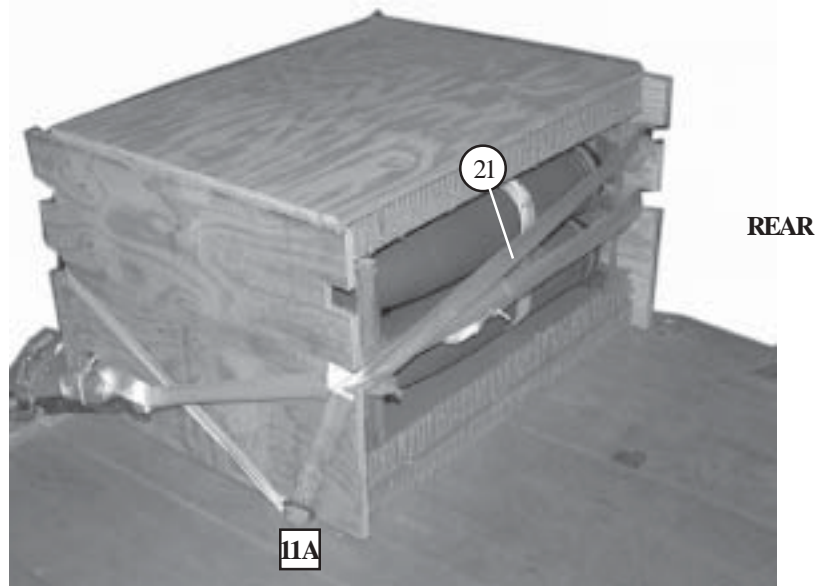

- ②1 Route a lashing through tiedown deck-ring 11A and through its own D-ring, through the front lower left cutout and through the rear upper left cutout through the rear upper right cutout.
- ②2 Secure with a loadbinder to clevis 28.

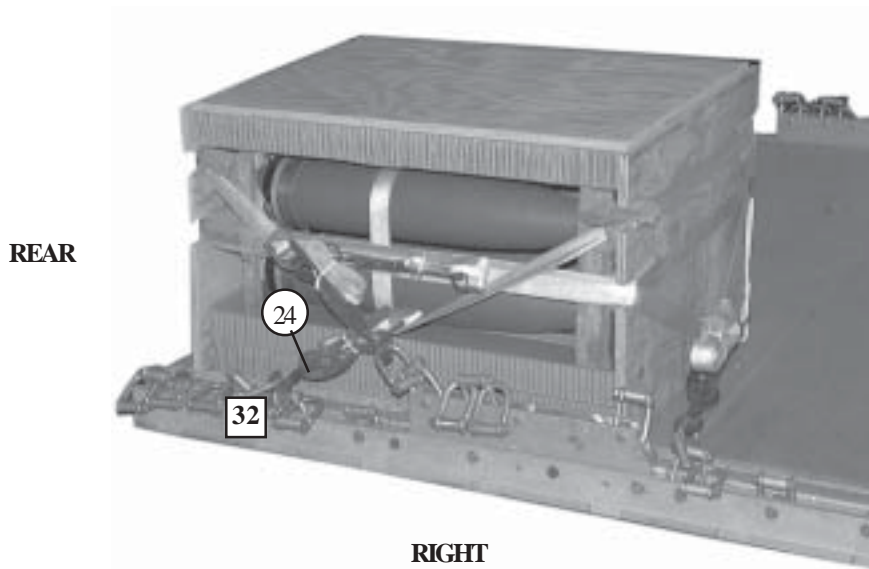
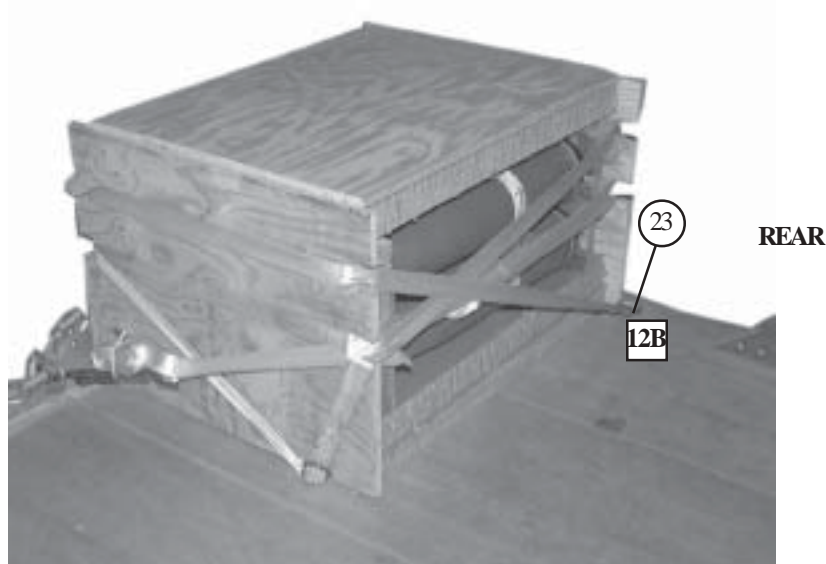

- ②3 Route a lashing through tiedown deck-ring and through its own D-ring on 12B, through the front upper cutouts.
- ②4 Secure with a loadbinder to clevis 32.

Figure 5-3. Accompanying load on the platform prepared (Continued)

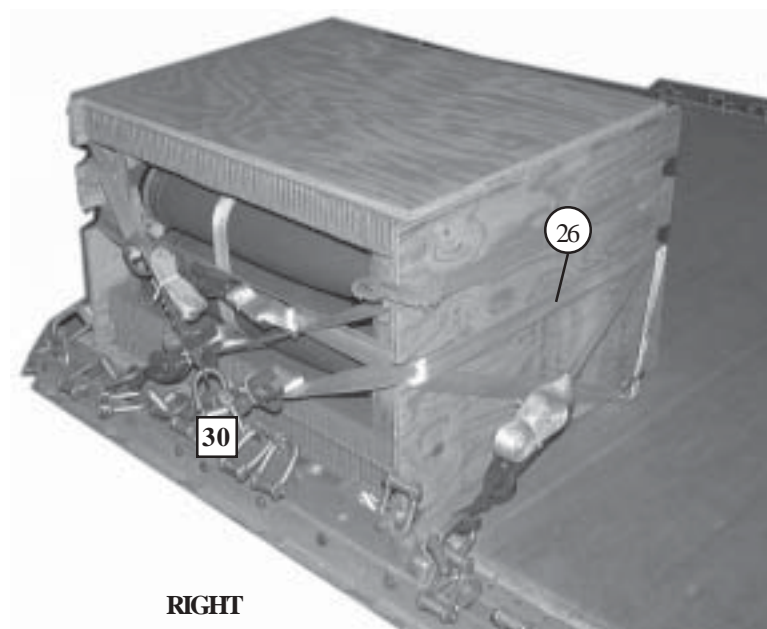
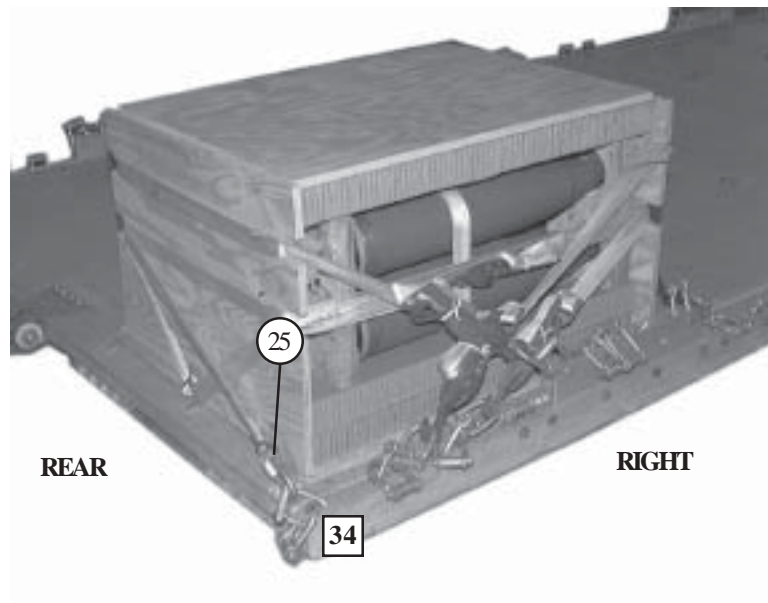

- ②5 Route a lashing through clevis 34 and its own D-ring, through the lower left cutouts.
- ②6 Secure with a loadbinder to clevis 30.

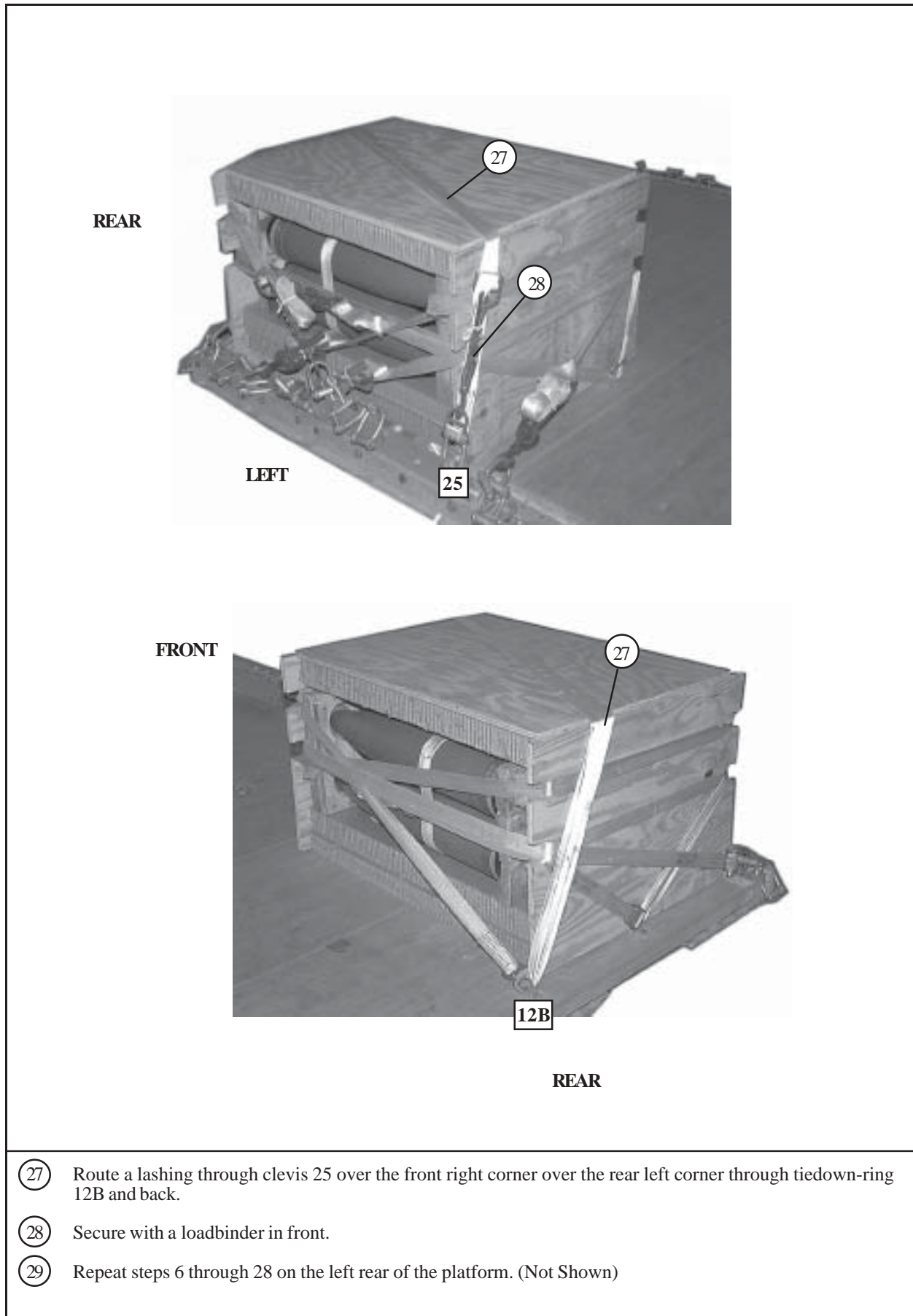
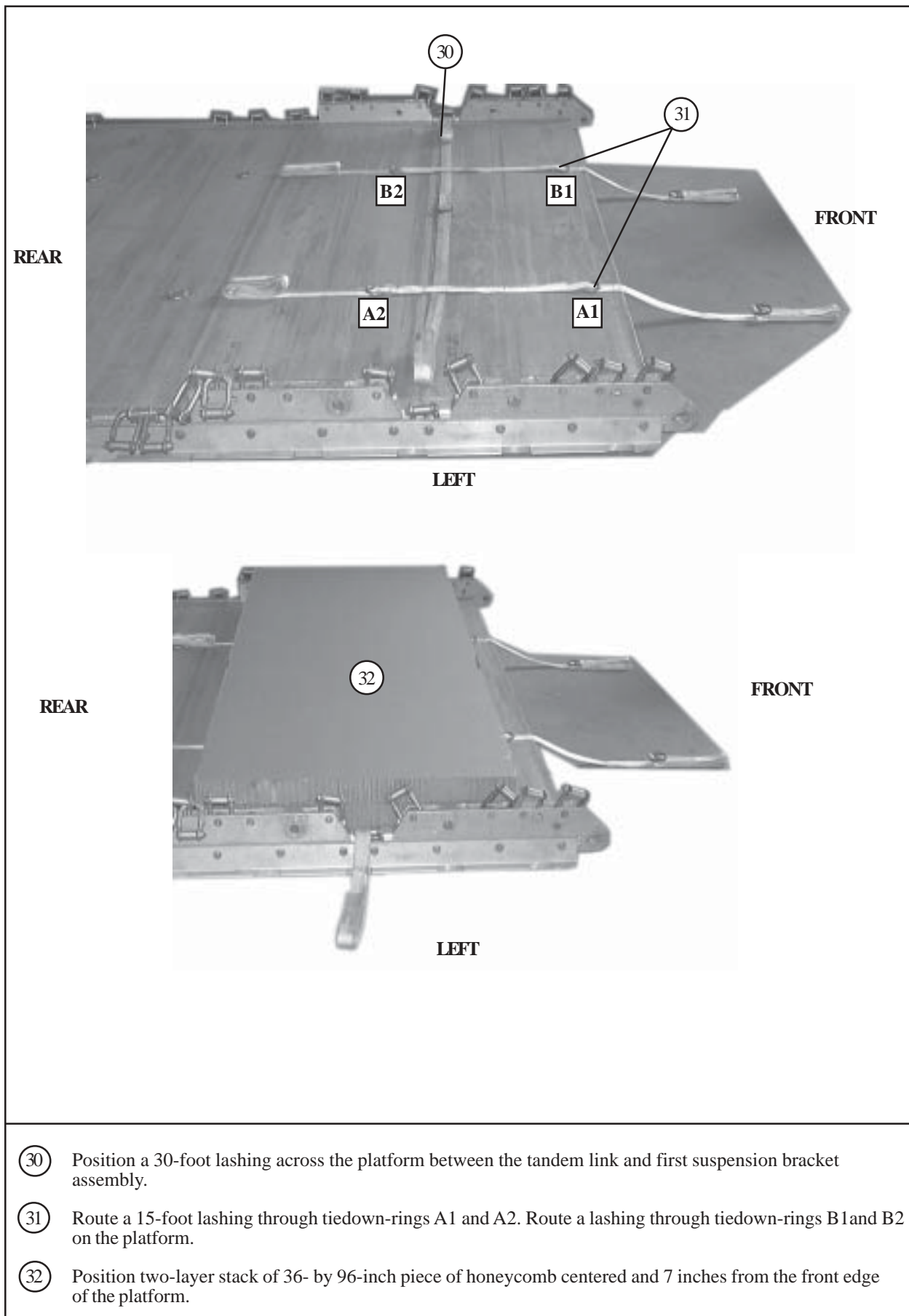

Figure 5-3. Accompanying load on the platform prepared (Continued)



- ③① Position a 30-foot lashing across the platform between the tandem link and first suspension bracket assembly.
- ③② Route a 15-foot lashing through tiedown-rings A1 and A2. Route a lashing through tiedown-rings B1 and B2 on the platform.
- ③③ Position two-layer stack of 36- by 96-inch piece of honeycomb centered and 7 inches from the front edge of the platform.

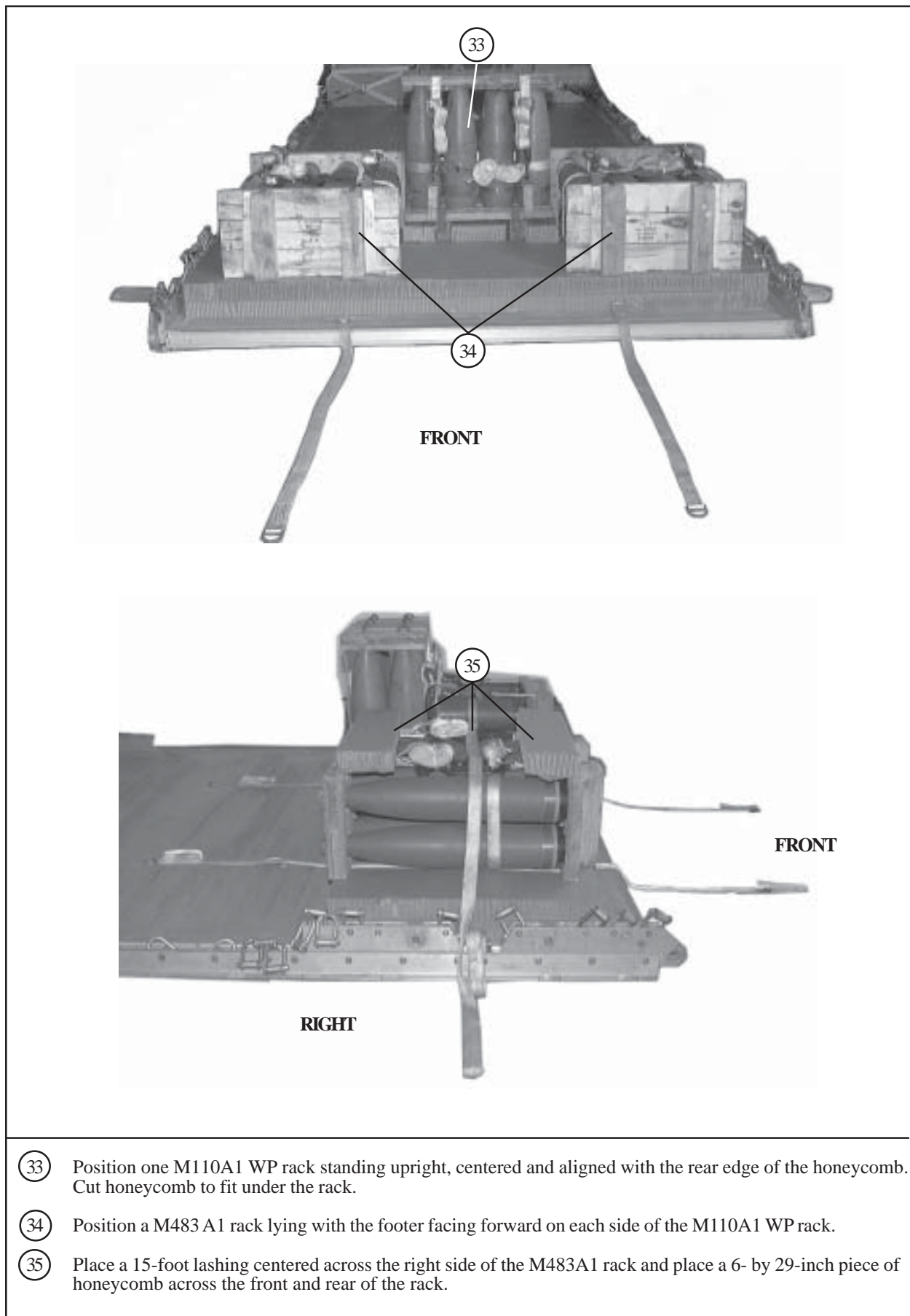
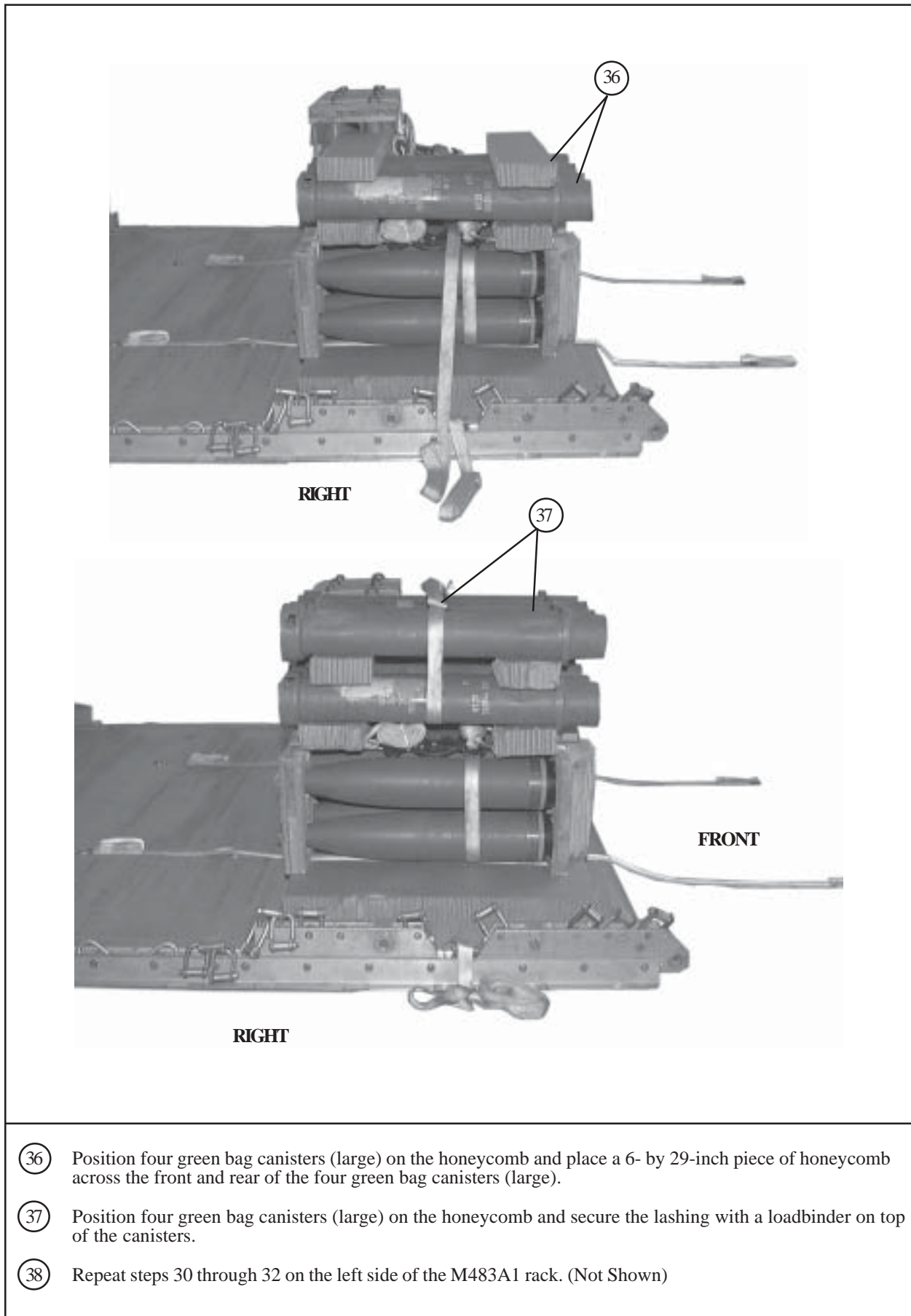

Figure 5-3. Accompanying load on the platform prepared (Continued)



- 36 Position four green bag canisters (large) on the honeycomb and place a 6- by 29-inch piece of honeycomb across the front and rear of the four green bag canisters (large).
- 37 Position four green bag canisters (large) on the honeycomb and secure the lashing with a loadbinder on top of the canisters.
- 38 Repeat steps 30 through 32 on the left side of the M483A1 rack. (Not Shown)

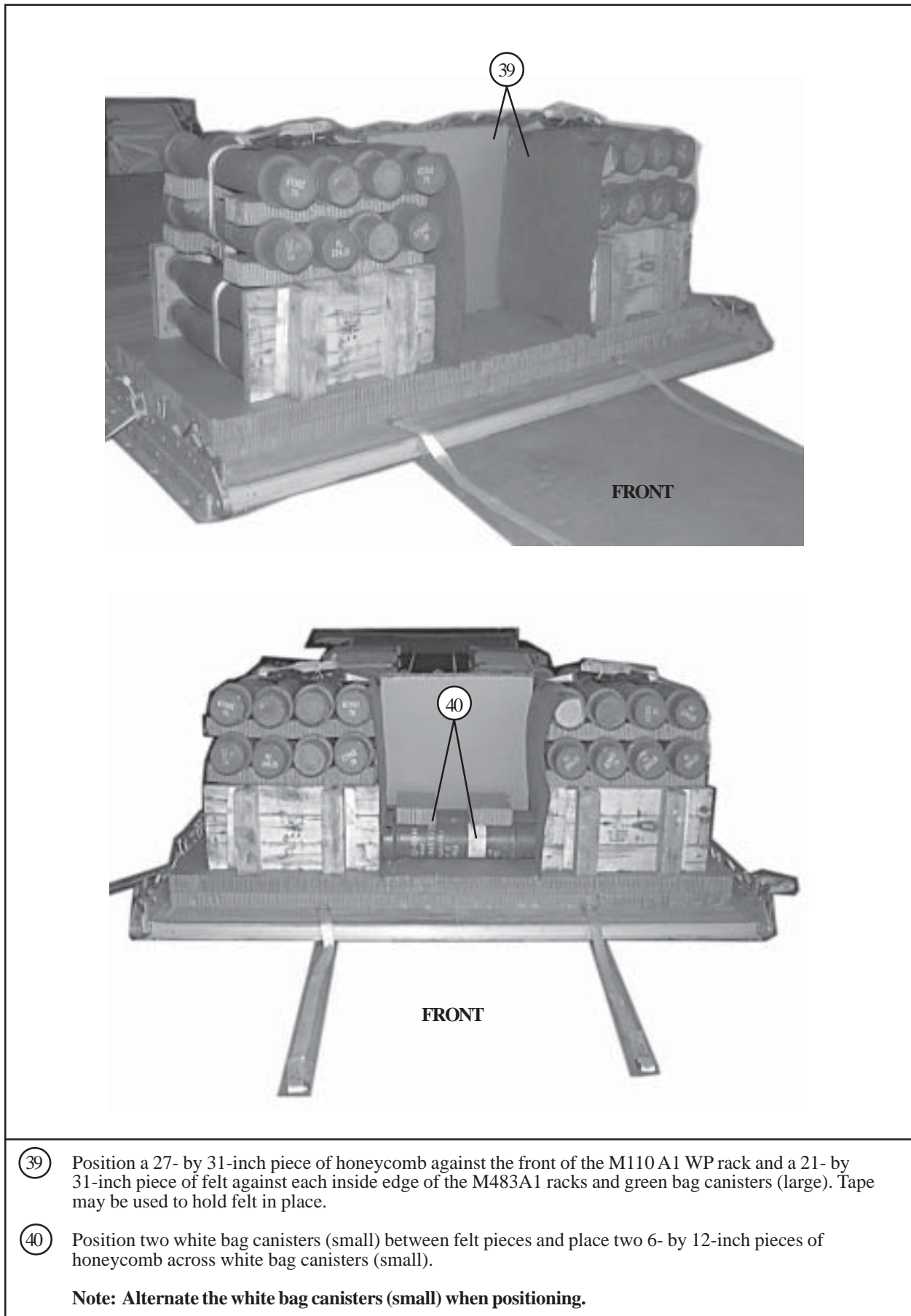
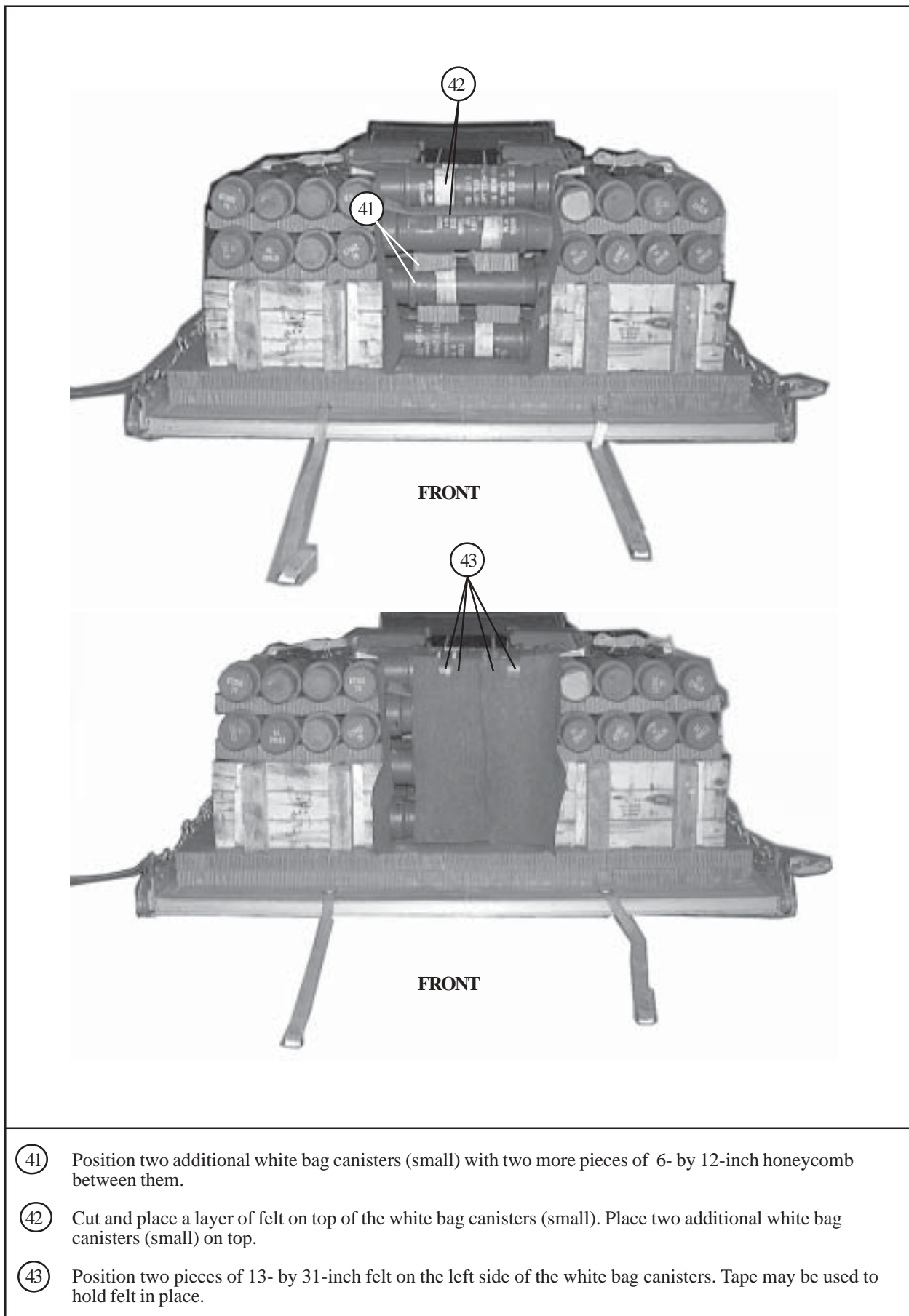

Figure 5-3. Accompanying load on the platform prepared (Continued)



- ④1 Position two additional white bag canisters (small) with two more pieces of 6- by 12-inch honeycomb between them.
- ④2 Cut and place a layer of felt on top of the white bag canisters (small). Place two additional white bag canisters (small) on top.
- ④3 Position two pieces of 13- by 31-inch felt on the left side of the white bag canisters. Tape may be used to hold felt in place.

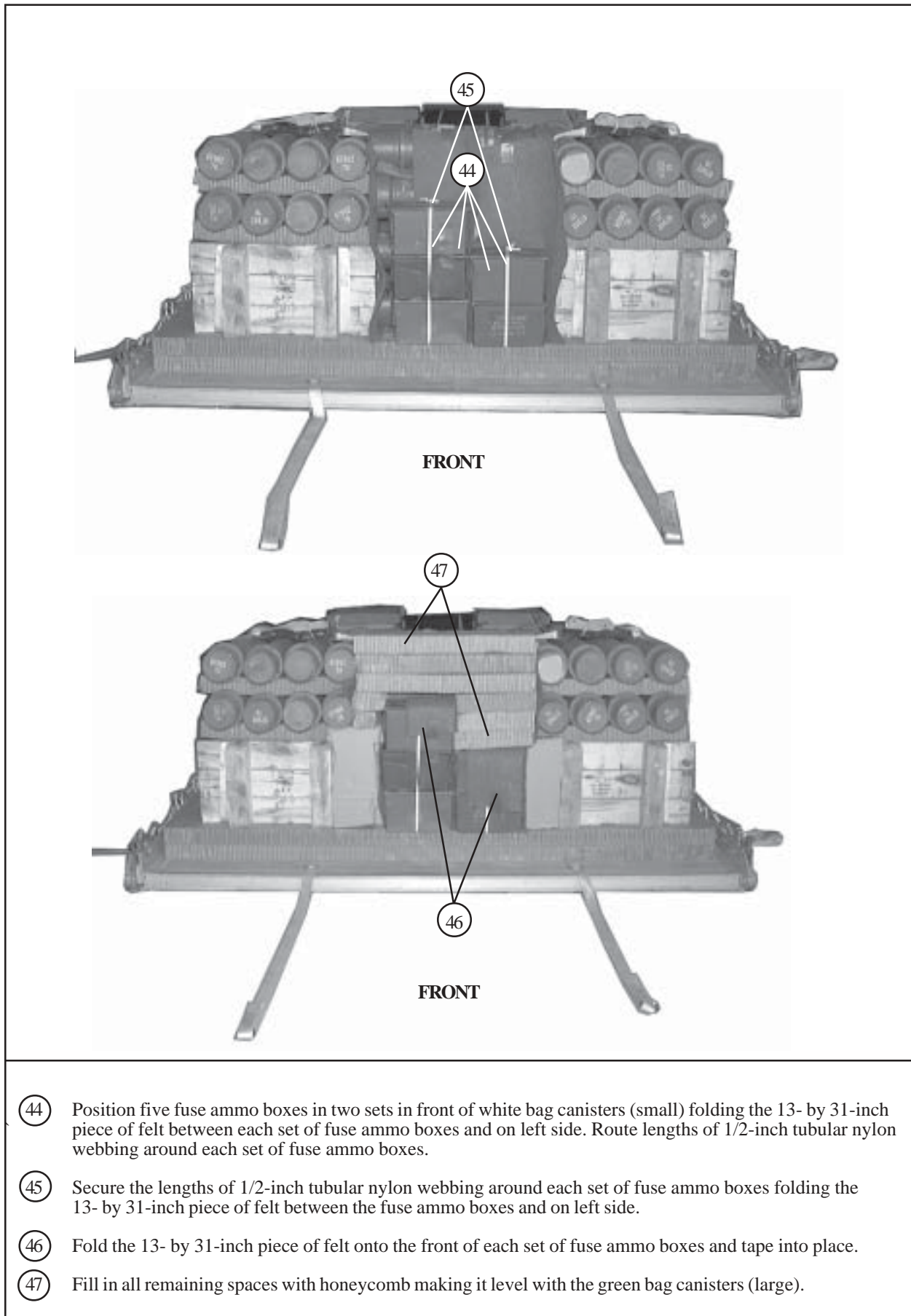
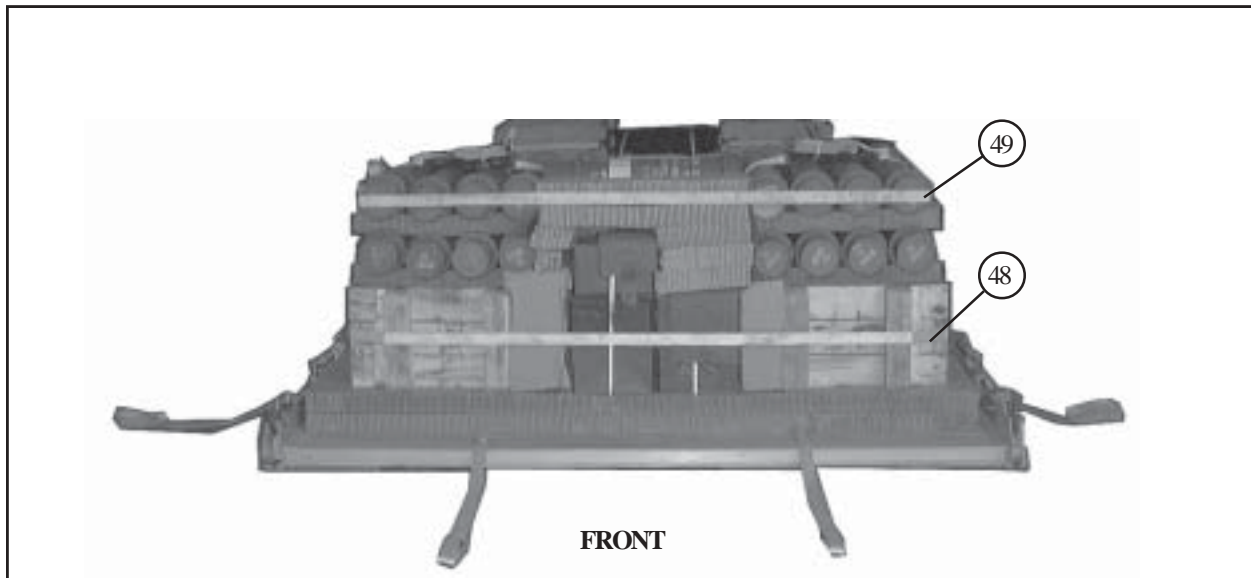
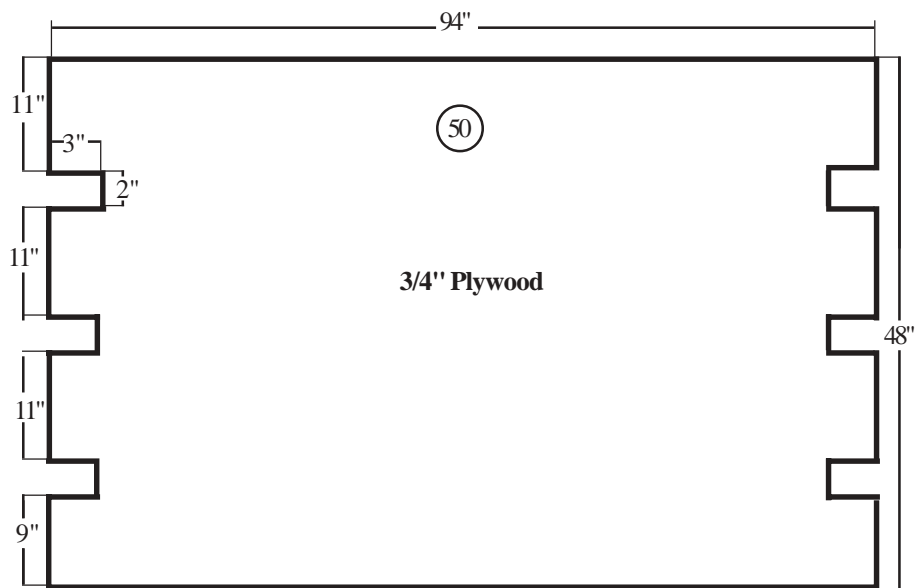

Figure 5-3. Accompanying load on the platform prepared (Continued)



- Notes: 1. This drawing is not drawn to scale.
2. All measurements are given in inches.



- (48) Route a 30-foot lashing around the M483 racks and secure with loadbinder on the side.
- (49) Route a 30-foot lashing around the top layer of green bag canisters and secure with loadbinder on the side.
- (50) Construct four endboards as shown in diagram above with 2- by 3-inch deep cutouts.

Note: Use two endboards per side.

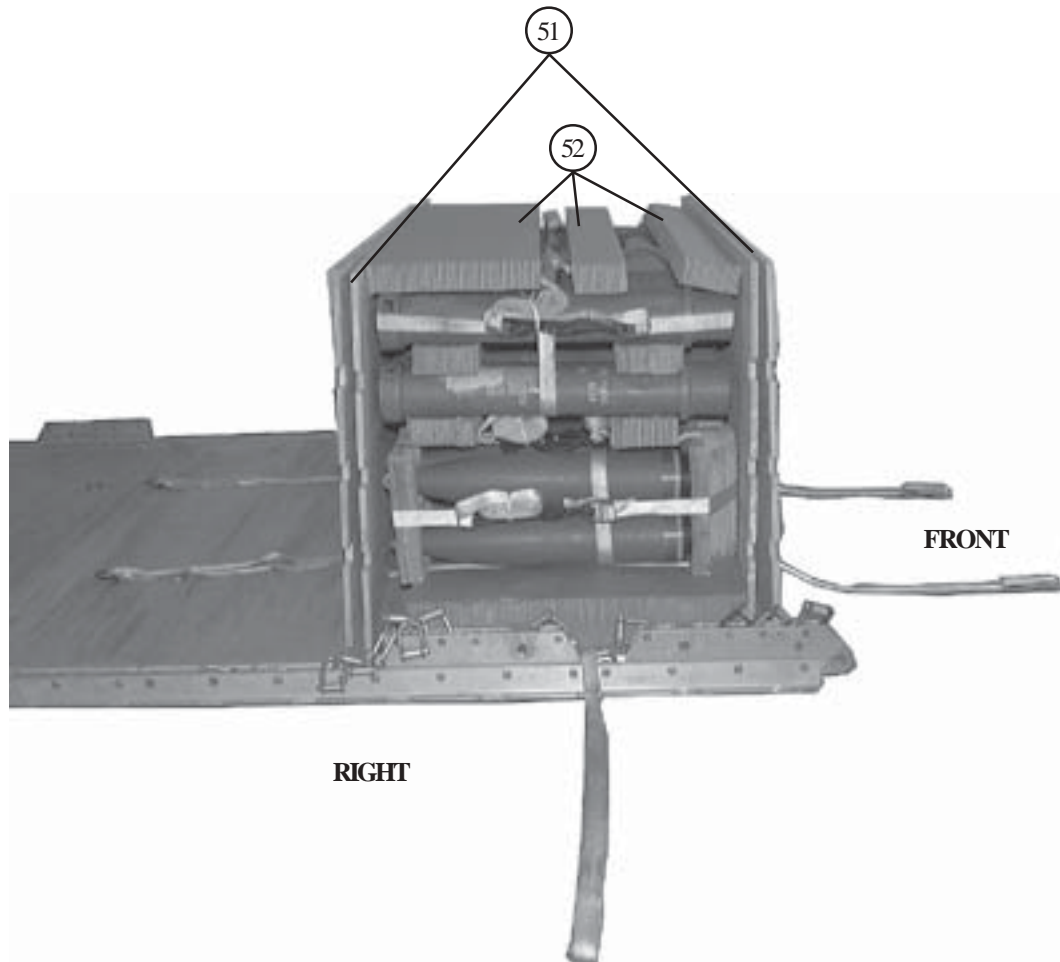

- ⑤1 Position two endboards to the front and two to the rear of the accompanying load.
- ⑤2 Place cut-to-fit honeycomb on top of the green bag canisters to make it level with the top of the endboards.

Figure 5-3. Accompanying load on the platform prepared (Continued)

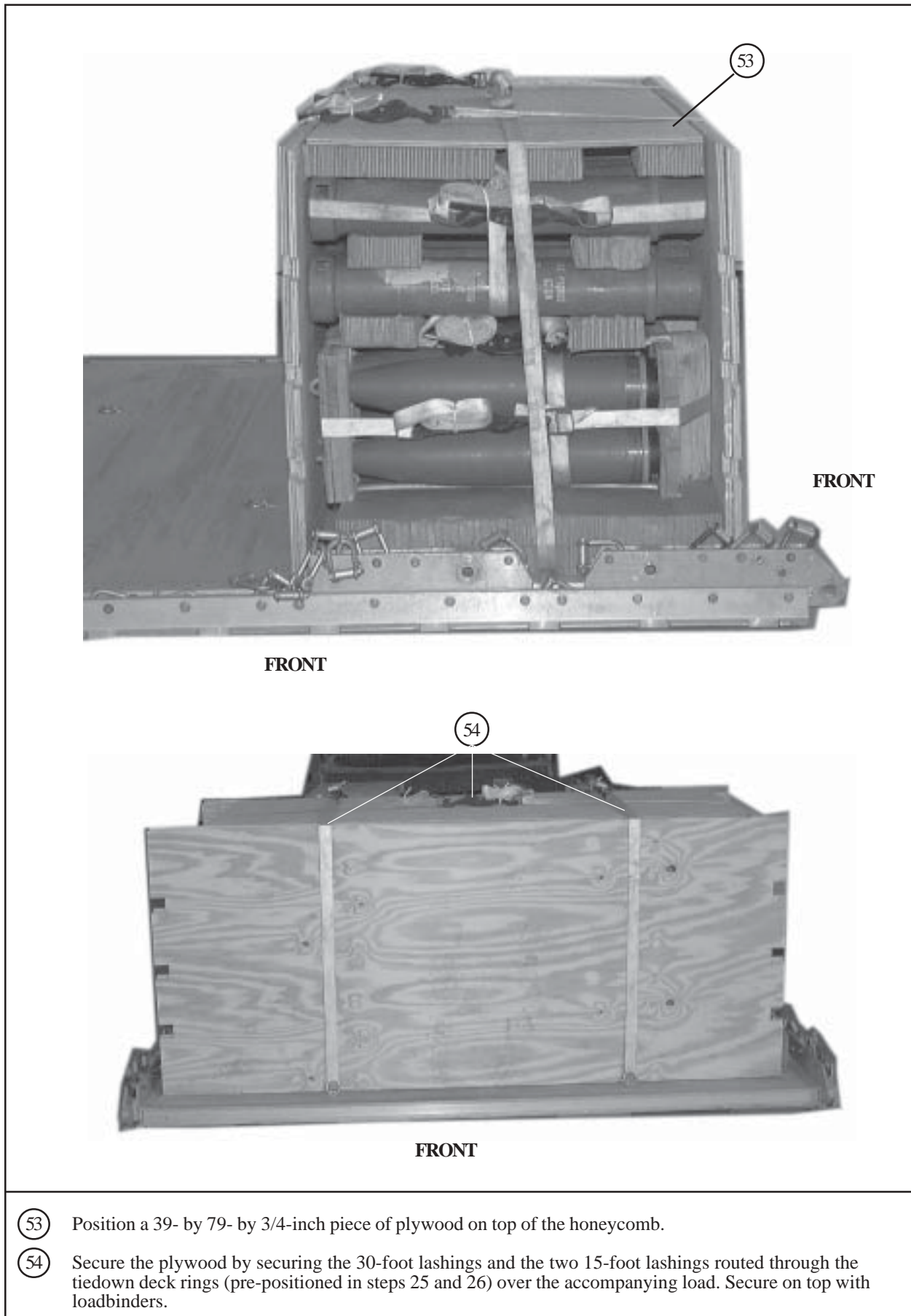

- ⑤③ Position a 39- by 79- by 3/4-inch piece of plywood on top of the honeycomb.
- ⑤④ Secure the plywood by securing the 30-foot lashings and the two 15-foot lashings routed through the tiedown deck rings (pre-positioned in steps 25 and 26) over the accompanying load. Secure on top with loadbinders.

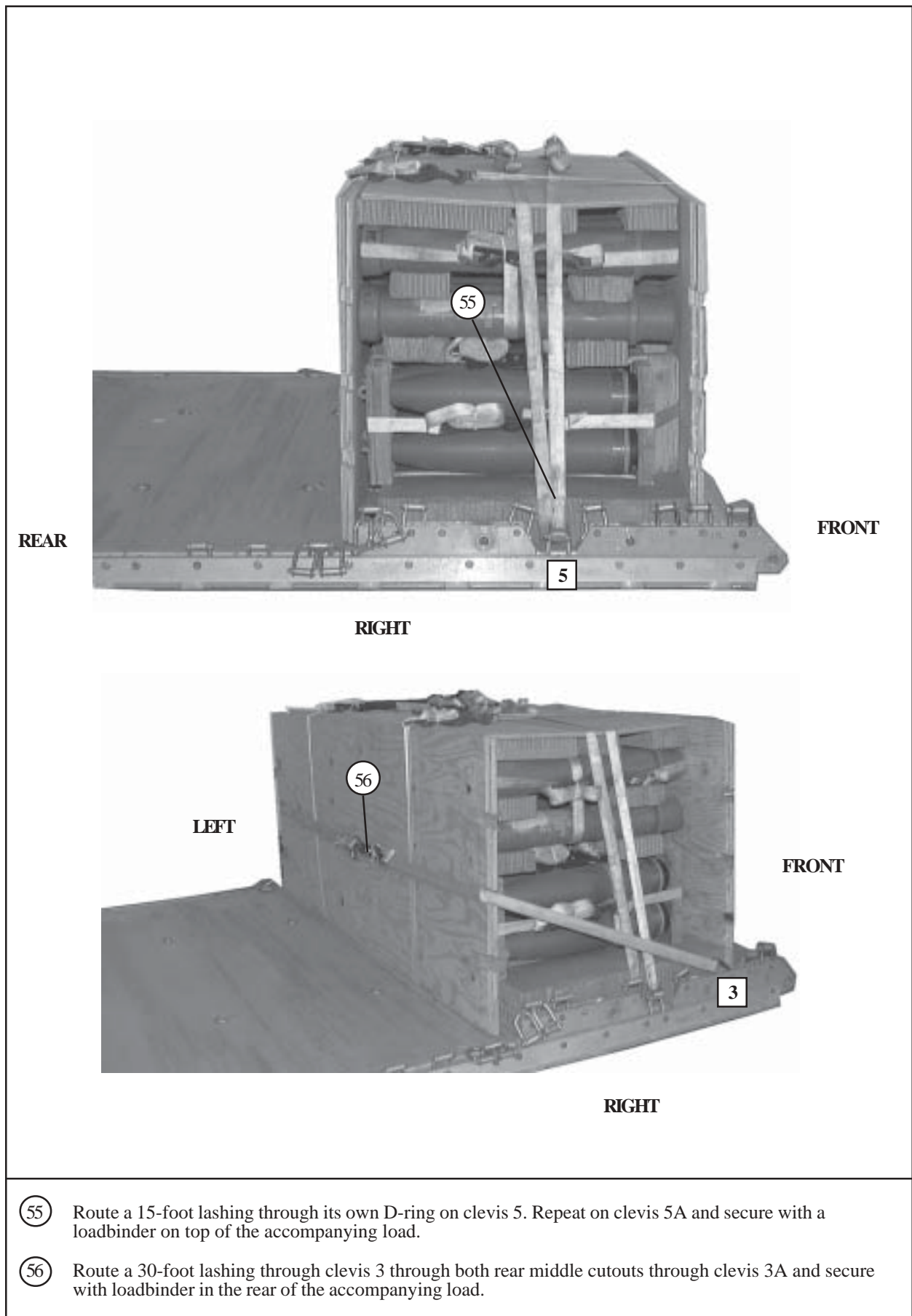
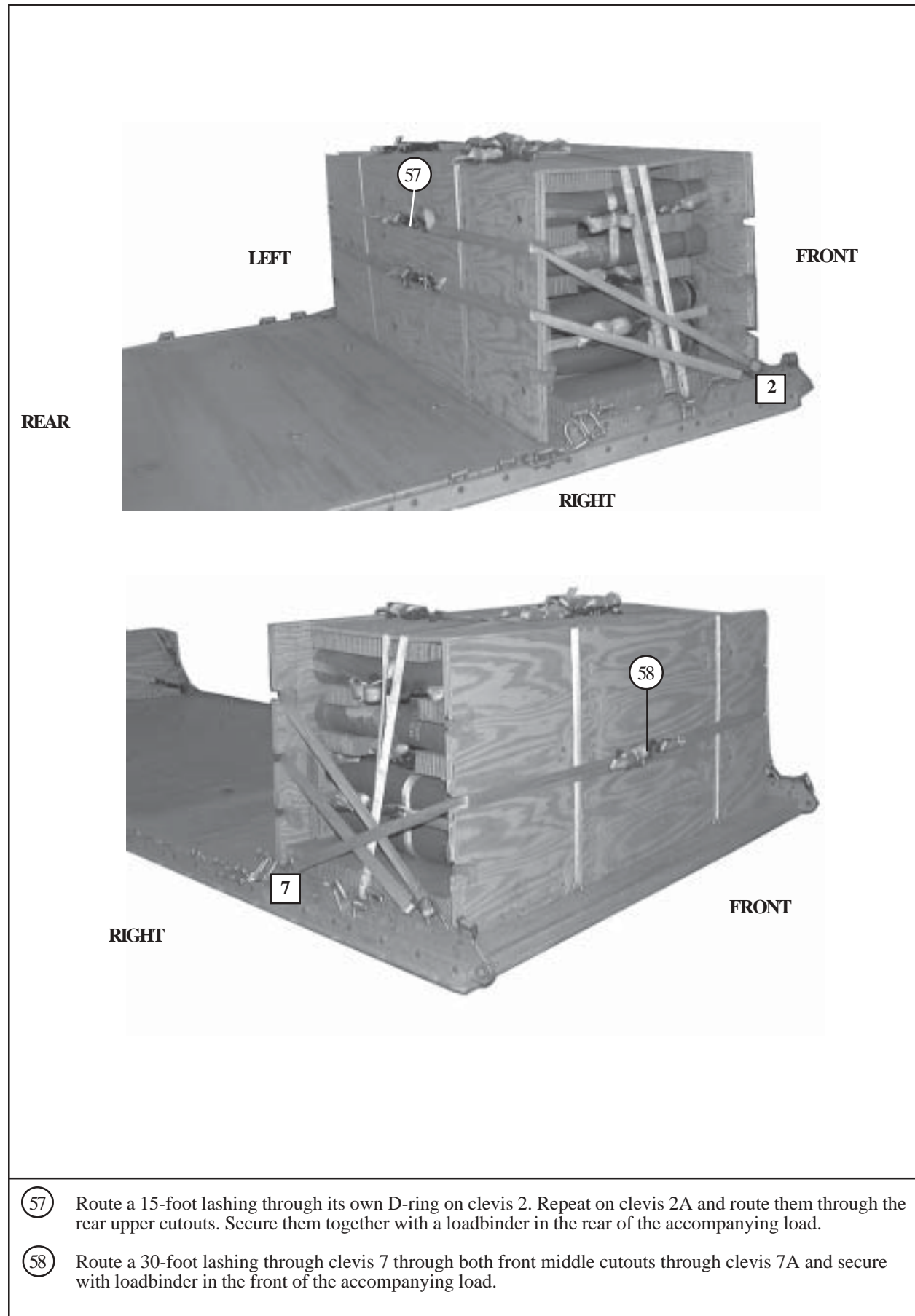
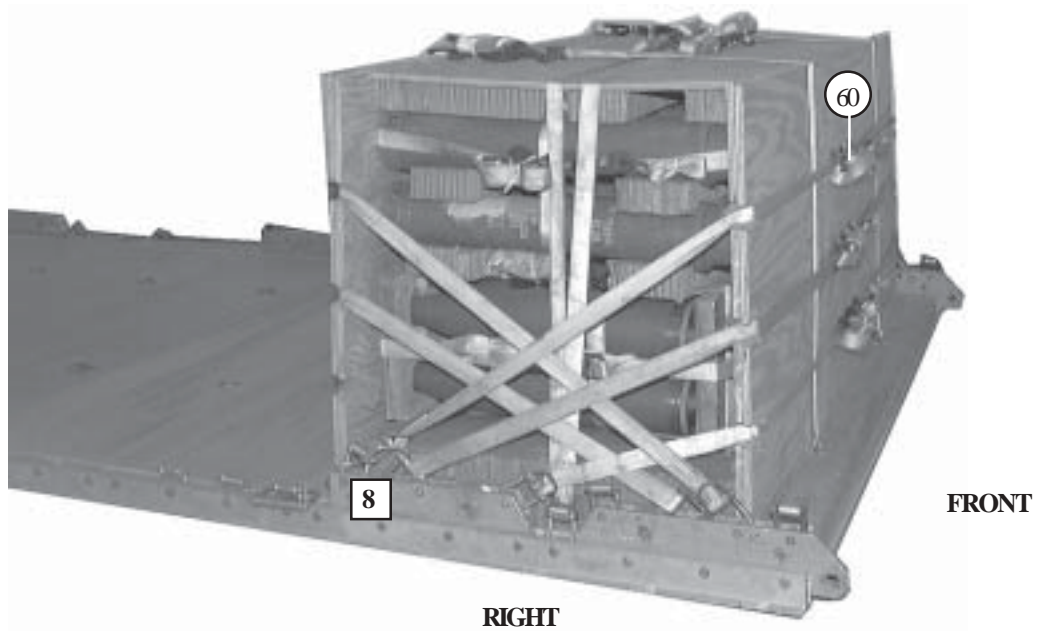
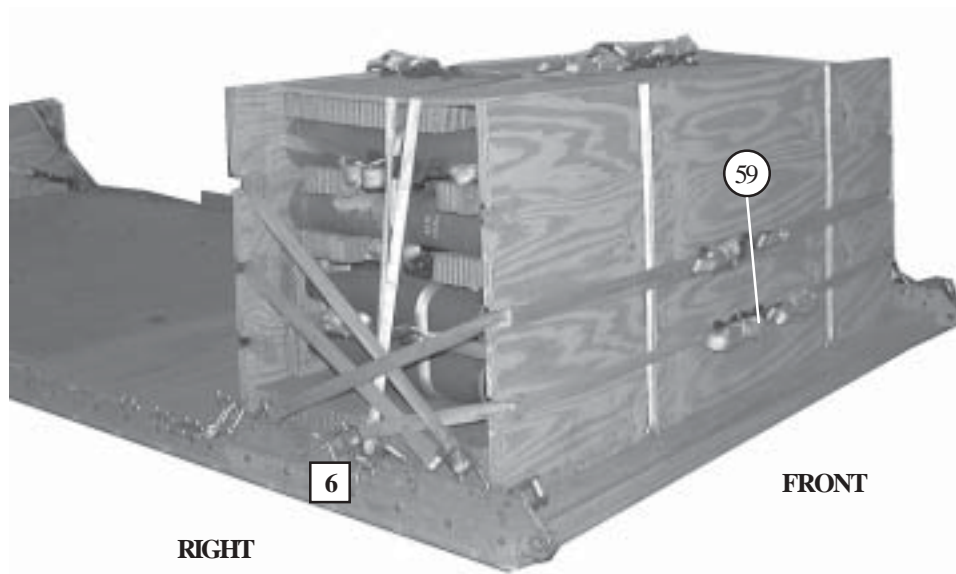

Figure 5-3. Accompanying load on the platform prepared (Continued)



- ⑤⑦ Route a 15-foot lashing through its own D-ring on clevis 2. Repeat on clevis 2A and route them through the rear upper cutouts. Secure them together with a loadbinder in the rear of the accompanying load.
- ⑤⑧ Route a 30-foot lashing through clevis 7 through both front middle cutouts through clevis 7A and secure with loadbinder in the front of the accompanying load.



- (59) Route a 15-foot lashing through its own D-ring on clevis 6. Repeat on clevis 6A and route them through the front lower cutouts. Secure them together with a loadbinder in front of the accompanying load.
- (60) Route a 15-foot lashing through its own D-ring on clevis 8. Repeat on clevis 8A and route them through the front upper cutouts. Secure with loadbinder in the front of the accompanying load.

Figure 5-3. Accompanying load on the platform prepared (Continued)

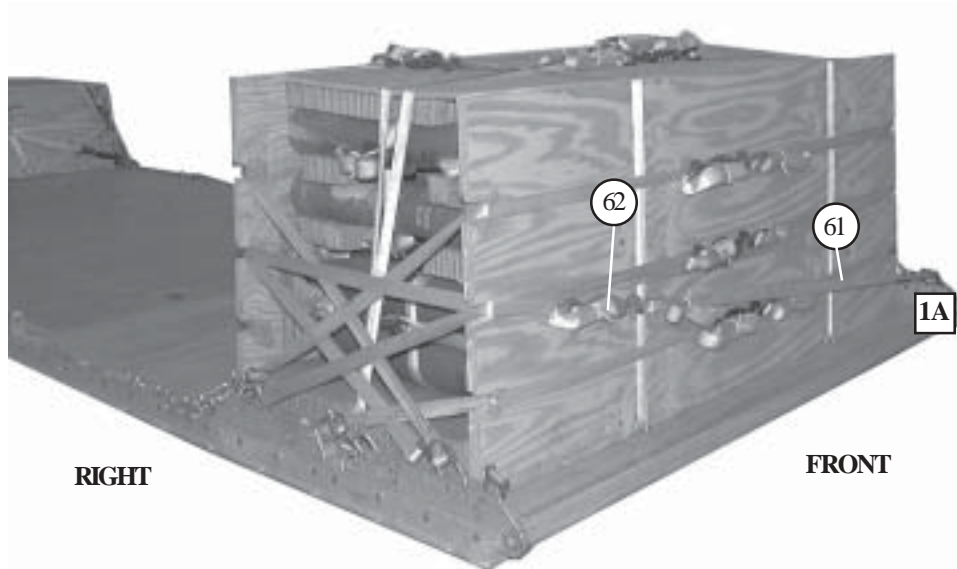

- ① Route a 15-foot lashing through its own D-ring on clevis 1A. Repeat on clevis 10A.
- ② Route lashing from clevis 10A through the rear and front middle cutouts. Secure lashing from 1A and 10A with a loadbinder in the front of the accompanying load.

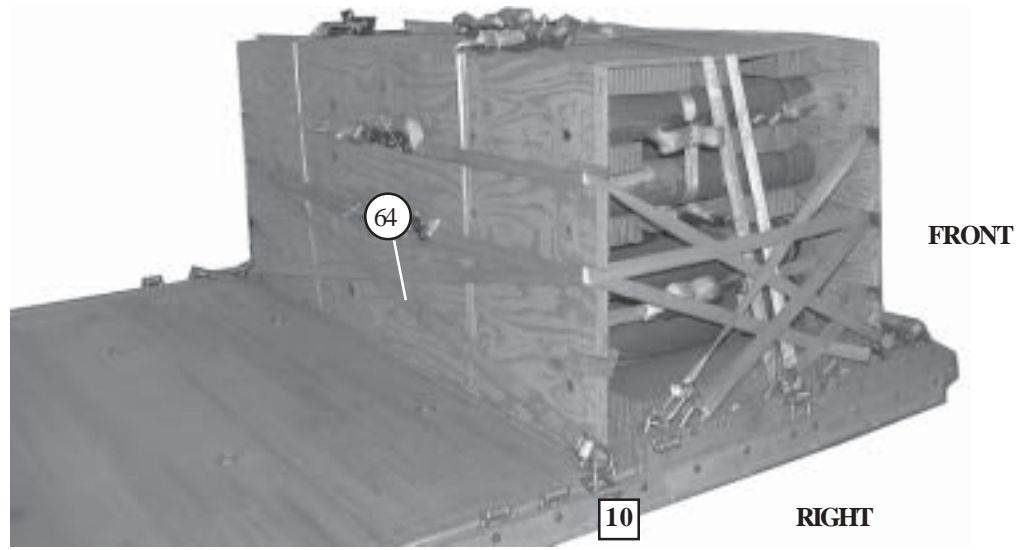
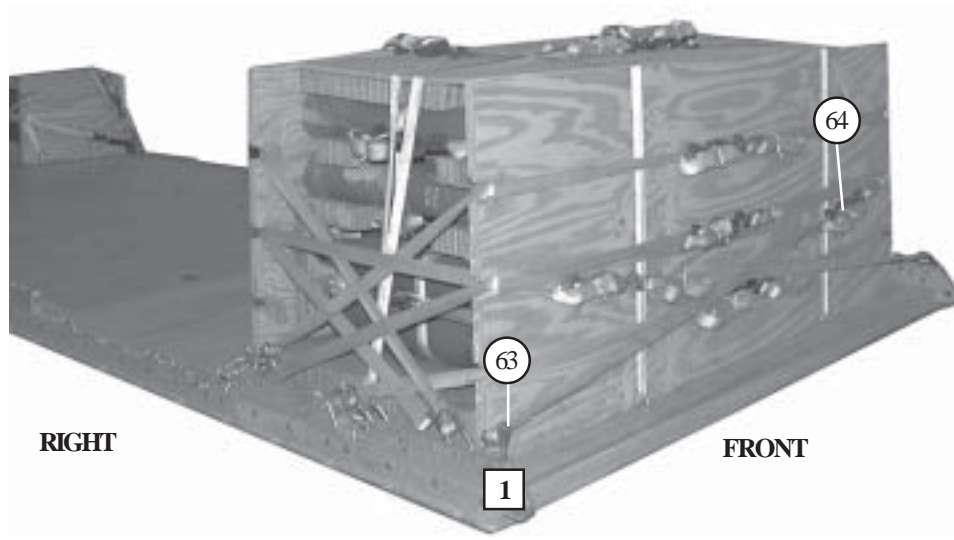

- ⑥③ Route a 15-foot lashing through its own D-ring on clevis 1. Repeat on clevis 10.
- ⑥④ Route lashing from clevis 10 through the rear and front middle cutouts. Secure lashings from clevises 1 and 10 with a loadbinder in the front of the accompanying load.

Figure 5-3. Accompanying load on the platform prepared (Continued)

5-4. Preparing Honeycomb Stacks

Use the material in *Table 5-1* to prepare seven honeycomb stacks as shown in *Figures 5-4 through 5-9*.

Table 5-1. Material needed to build honeycomb stacks.

Stack Number	Pieces	Width (Inches)	Length (Inches)	Material	Instructions
1	9	20	52	Honeycomb	See <i>Figure 5-4</i> .
	4	8	52	Honeycomb	
	2	20	52	3/4-inch plywood	
	6	2- by 4	20	Lumber	
	2	4- by 4	52	Lumber	
	2	4- by 4	7	Lumber	
	4	2- by 4	7	Lumber	
2	5	36	48	Honeycomb	See <i>Figure 5-5</i> .
	5	10	48	Honeycomb	
	3	9	48	Honeycomb	
	2	46	48	3/4-inch plywood	
	6	4- by 4	46	Lumber	
	3	4- by 4	48	Lumber	
	5	2- by 6	10 1/2	Lumber	
	3	4- by 4	19	Lumber	
1	2- by 4	18	Lumber		
3	24	24	40	Honeycomb	See <i>Figure 5-6</i> .
	8	8	40	Honeycomb	
	6	4- by 4	40	Lumber	
	2	40	48	3/4-inch plywood	
4	12	24	40	Honeycomb	See <i>Figure 5-7</i> .
	4	8	40	Honeycomb	
	2	24	40	3/4-inch plywood	
	4	4- by 4	40	Lumber	
5	10	24	30	Honeycomb	See <i>Figure 5-8</i> .
	4	8	30	Honeycomb	
	4	4- by 4	30	Lumber	
	2	24	30	3/4-inch plywood	
	3	2- by 6	30	Lumber	
	3	6	30	3/4-inch plywood	
	3	5 1/2	30	3/4-inch plywood	
6	2	18	96	Honeycomb	See <i>Figure 5-9</i> .
7	2	18	96	Honeycomb	See <i>Figure 5-9</i> .

- Notes: 1. This drawing is not drawn to scale.
 2. All measurements are given in inches.
 3. Do **NOT** glue wooden stack to honeycomb.
 4. All nails used are size 8d.

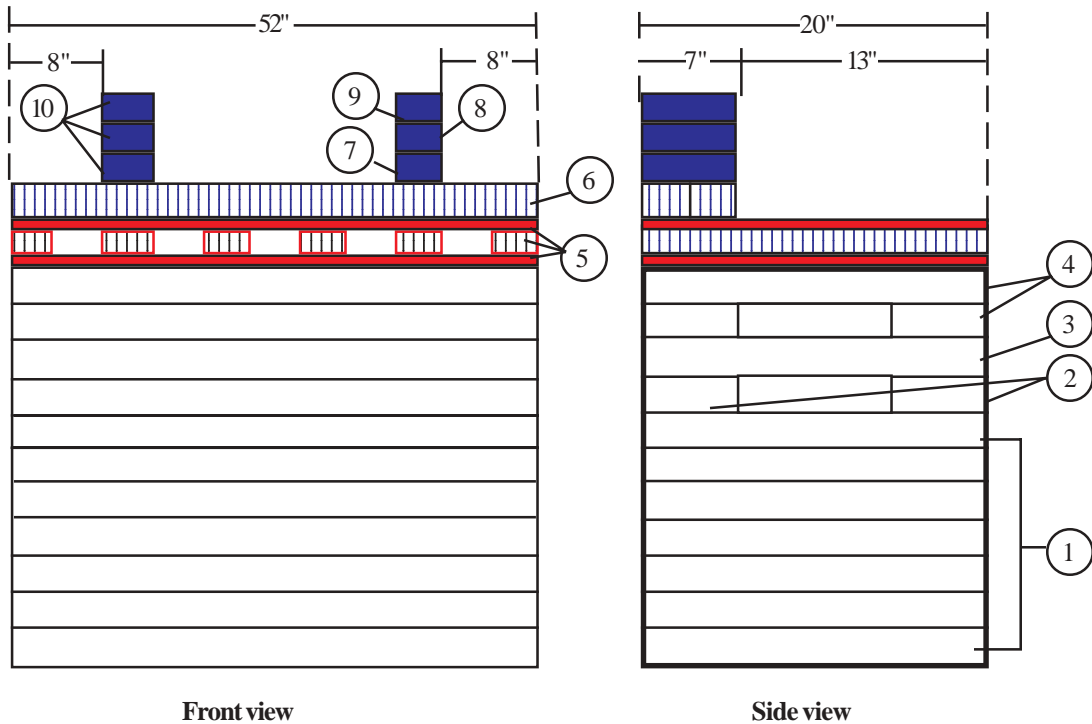

- ① Glue seven 20- by 52-inch pieces of honeycomb together.
- ② Glue two 8- by 52-inch pieces of honeycomb flush front and rear on the 52-inch sides of the top of the 20- by 52-inch pieces of honeycomb.
- ③ Glue a 20- by 52-inch piece of honeycomb on top of the two 8- by 52-inch pieces of honeycomb.
- ④ Repeat steps 2 and 3 to complete the base.
- ⑤ Nail six 2- by 4- by 20-inch pieces of lumber evenly spaced across the 20-inch width of a 20- by 52-inch piece of 3/4-inch plywood. Nail another 20- by 52-inch piece of 3/4-inch plywood on top of the six 2- by 4- by 20-inch pieces of lumber.
- ⑥ Nail two 4- by 4- by 52-inch pieces of lumber to the rear top edge of the 20- by 52-inch piece of 3/4-inch plywood a long the 52 inch side.
- ⑦ Nail a 2- by 4- by 7-inch piece of lumber across the top of the two 4- by 4- by 52-inch pieces of lumber, 8 inches in from the 20 inch side of the stack.
- ⑧ Nail a 4- by 4- by 7-inch piece of lumber to the top of the 2- by 4- by 7-inch pieces of lumber.
- ⑨ Nail a 2- by 4- by 7-inch piece of lumber to the top of the 4- by 4- by 7-inch piece of lumber.
- ⑩ Repeat steps 7 through 9 for the other side.

Figure 5-4. Stack 1 prepared

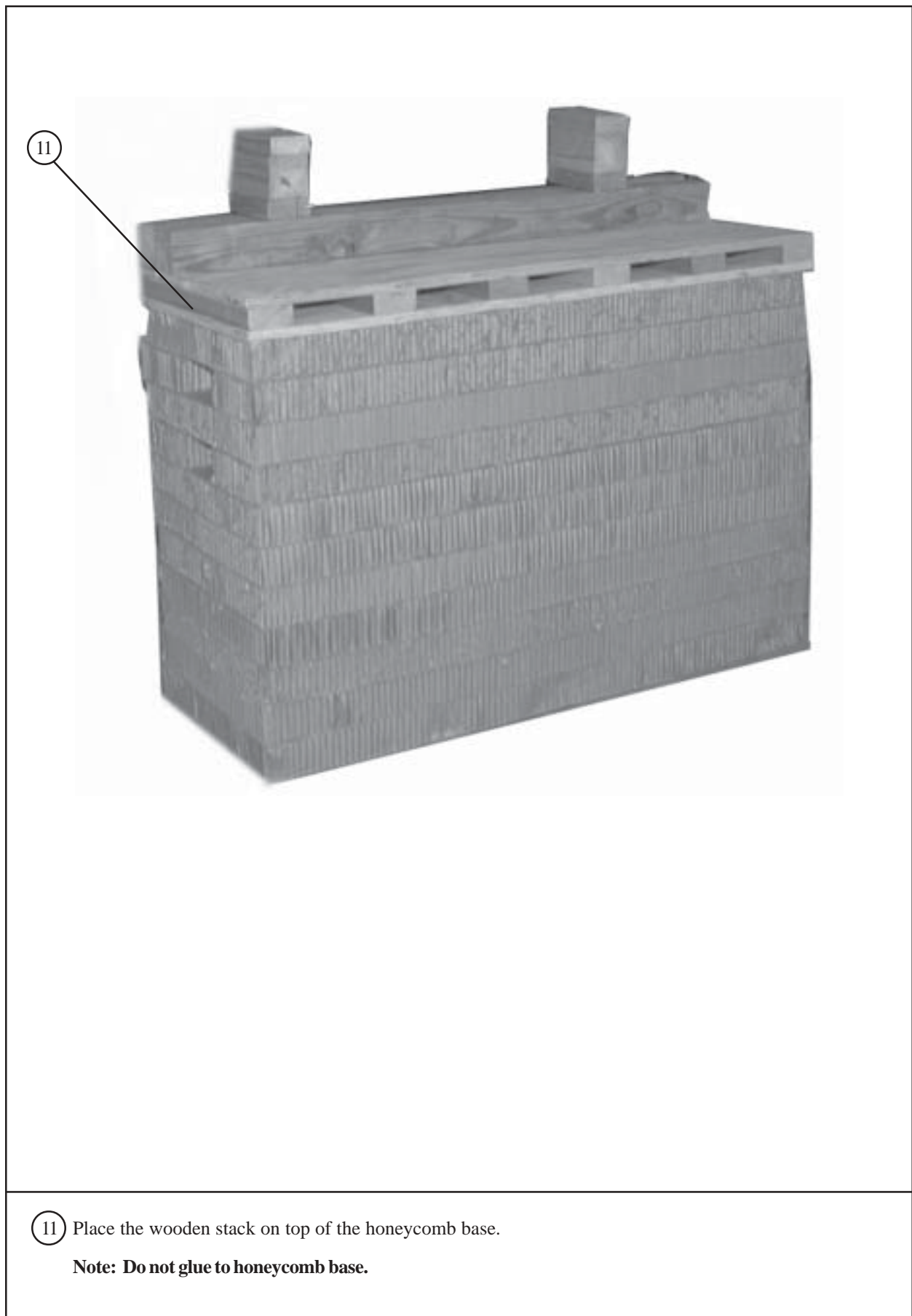

- Notes:**
1. This drawing is not drawn to scale.
 2. All measurements are given in inches.
 3. Do **NOT** glue wooden stack to honeycomb.
 4. All nails used are size 8d.

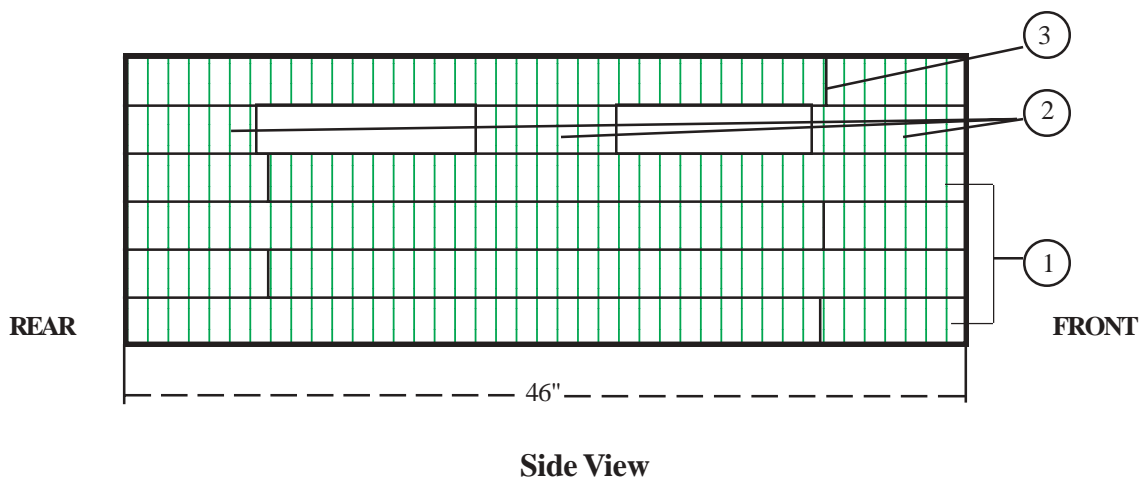

- ① Position a 36- by 48-inch piece of honeycomb beside a 10- by 48-inch piece of honeycomb. Alternate and glue three 36- by 48-inch pieces of honeycomb and three 10- by 48-inch pieces of honeycomb together to form the base.
- ② Glue two 9- by 48-inch piece of honeycomb flush with front and rear on the 48-inch side and on top of the 46- by 48-inch base. Position and glue a 9- by 48-inch piece of honeycomb centered on the 36- by 48-inch and 10- by 48-inch honeycomb stack.
- ③ Position and glue the third 36- by 48-inch piece of honeycomb centered on stack.

Figure 5-5. Stack 2 prepared

- Notes:**
1. This drawing is not drawn to scale.
 2. All measurements are given in inches.
 3. Do **NOT** glue wooden stack to honeycomb.
 4. All nails are used size 8d.

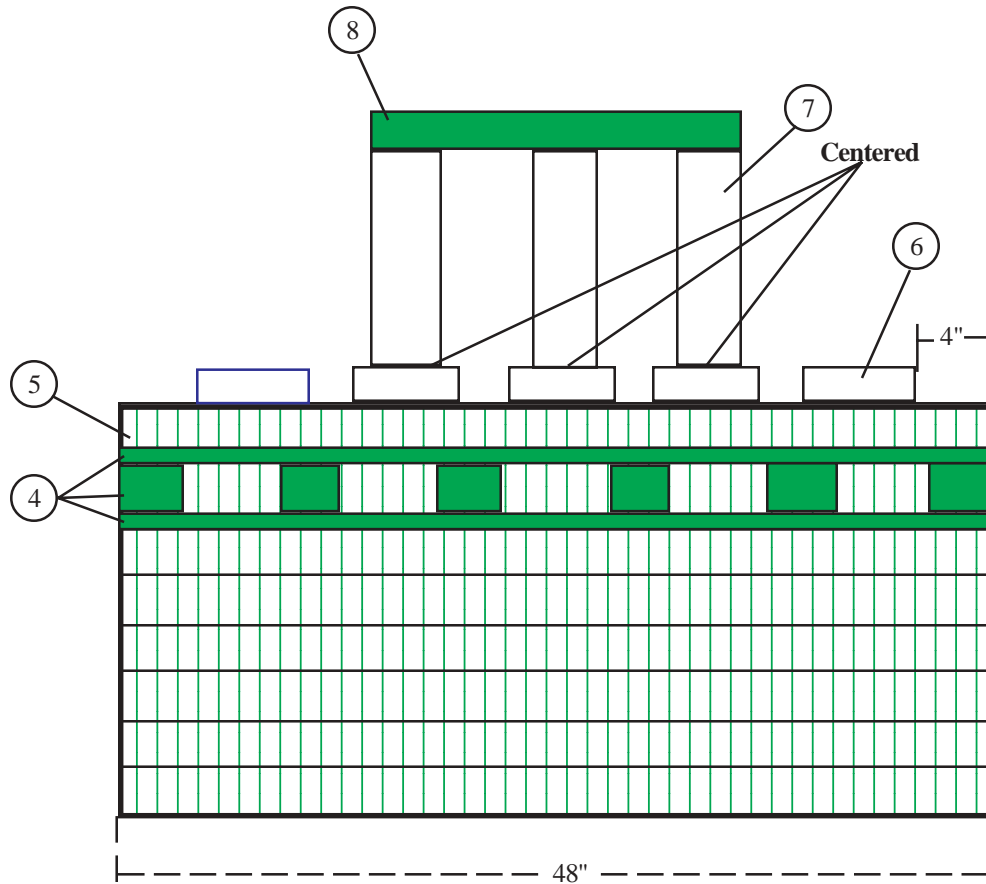

Front View

- 4 Nail six 4- by 4- by 46-inch pieces of lumber evenly spaced with the 46-inch side of a 46- by 48-inch piece of 3/4-inch plywood. Nail another 46- by 48-inch piece of 3/4-inch plywood on top of the six 4- by 4- by 46-inch pieces of lumber.
- 5 Position and nail three 4- by 4- by 48-inch pieces of lumber on top and centered on the 46- by 48-inch piece of 3/4-inch plywood along the 48 inch length.
- 6 Position and nail five 2- by 6- by 10-inch piece of lumber across the top of the three 4- by 4- by 48-inch pieces of lumber, 4 inches in from the 48-inch side.
- 7 Position and nail three 4- by 4- by 19-inch pieces of lumber upright and centered on top of the center three 2- by 6- by 10 1/2-inch pieces of lumber.
- 8 Position and nail a 2- by 4- by 18-inch piece of lumber on top of the three 4- by 4- by 19-inch pieces of lumber.

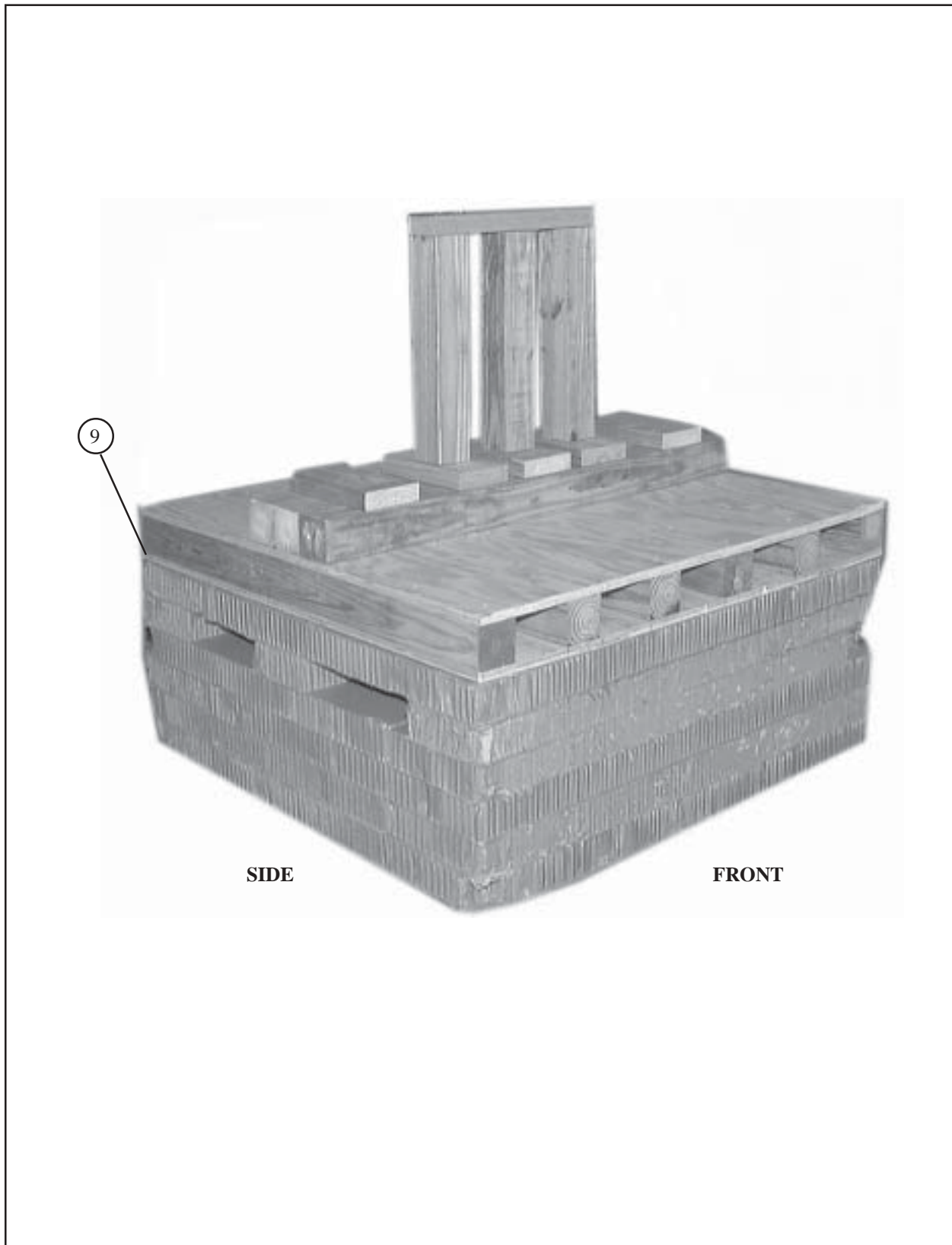

- ⑨ Place the wooden stack on top of the honeycomb stack base.

Note: Do not glue to honeycomb base.

Figure 5-5. Stack 2 prepared (Continued)

- Notes:**
1. This drawing is not drawn to scale.
 2. All measurements are given in inches.
 3. Do **NOT** glue wooden stack to honeycomb.
 4. All nails used are size 8d.

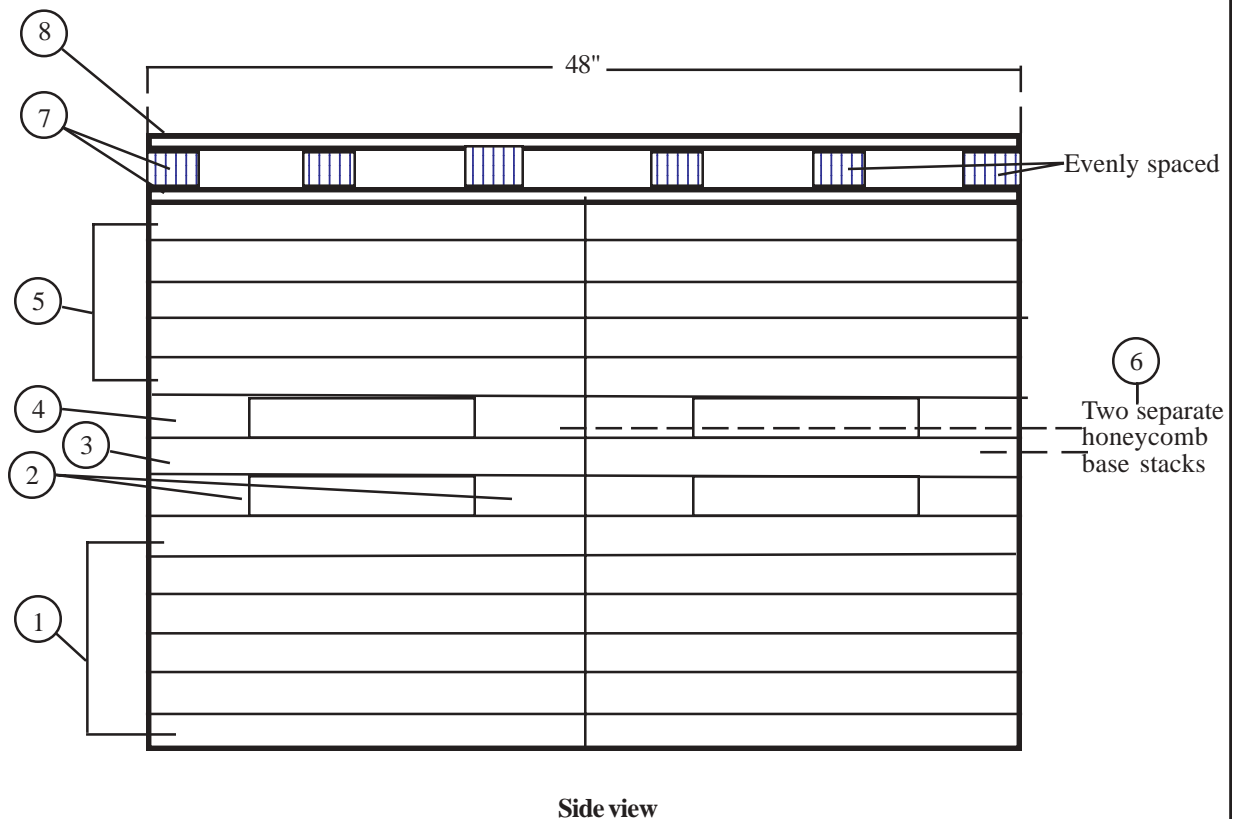

- 1 Build two separate honeycomb stacks. Glue six 24- by 40-inch pieces of honeycomb together.
- 2 Glue two 8- by 40-inch pieces of honeycomb on each 40 inch side of the six 24- by 40-inch pieces of honeycomb.
- 3 Glue a 24- by 40-inch piece of honeycomb on top of the two 8- by 40-inch pieces of honeycomb.
- 4 Glue two 8- by 40-inch pieces of honeycomb on each 40 inch side of the 24- by 40-inch piece of honeycomb.
- 5 Glue five 24- by 40-inch pieces of honeycomb together and on top of the two 8- by 40-inch pieces of honeycomb to form half of the honeycomb base.
- 6 Repeat steps 1 through 5 for the second honeycomb stack.
- 7 Nail six 4- by 4- by 40-inch pieces of lumber evenly spaced to a 40- by 48-inch piece of 3/4-inch plywood across the 40 inch side of the plywood.
- 8 Nail another 40- by 48-inch piece of 3/4-inch plywood on the top of the six 4- by 4- by 40-inch pieces of lumber.

Figure 5-6. Stack 3 prepared

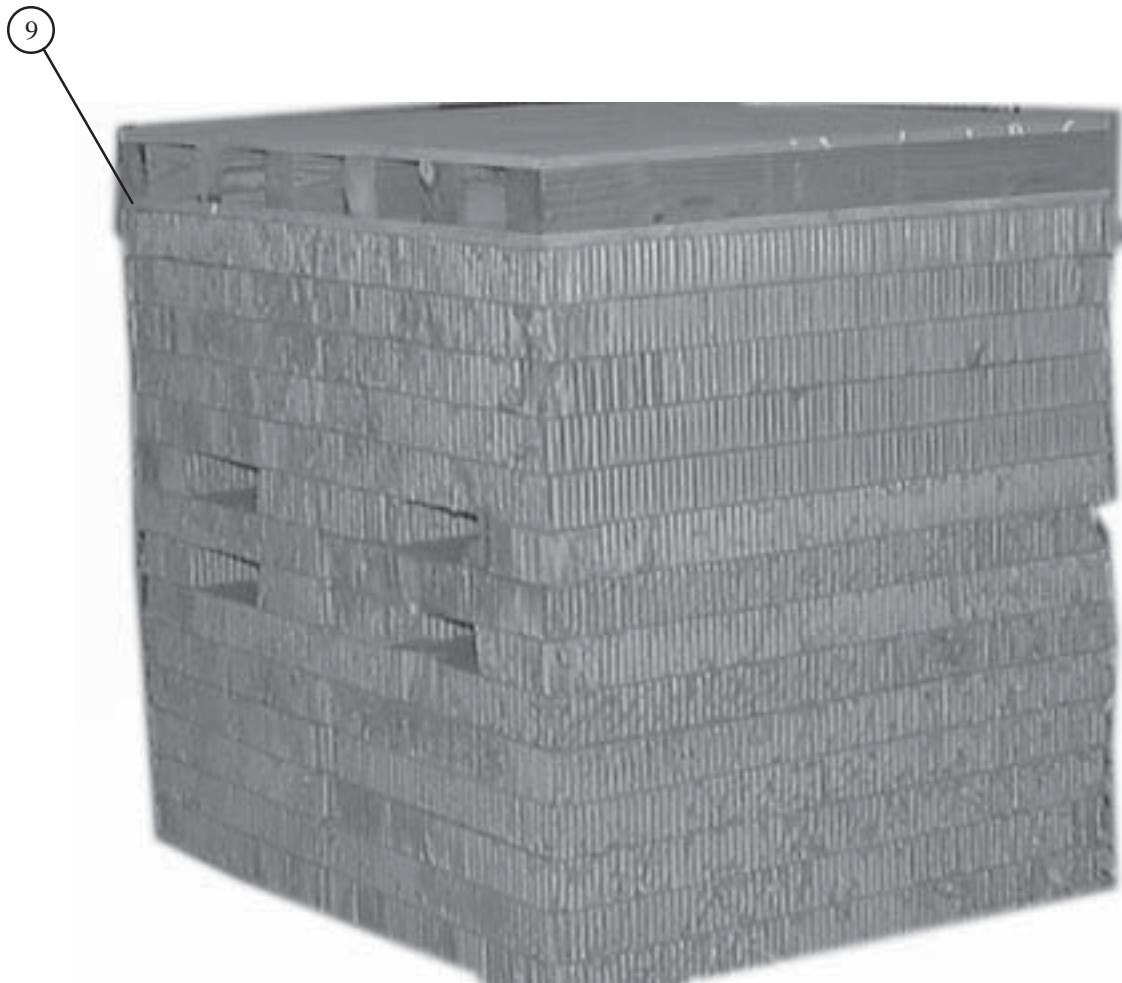

⑨ Place the wooden stack on top of the two honeycomb stacks base.

Note: Do not glue to honeycomb base.

Figure 5-6. Stack 3 prepared (Continued)

- Notes:**
1. This drawing is not drawn to scale.
 2. All measurements are given in inches.
 3. Do **NOT** glue wood to honeycomb.
 4. All nails used are size 8d.

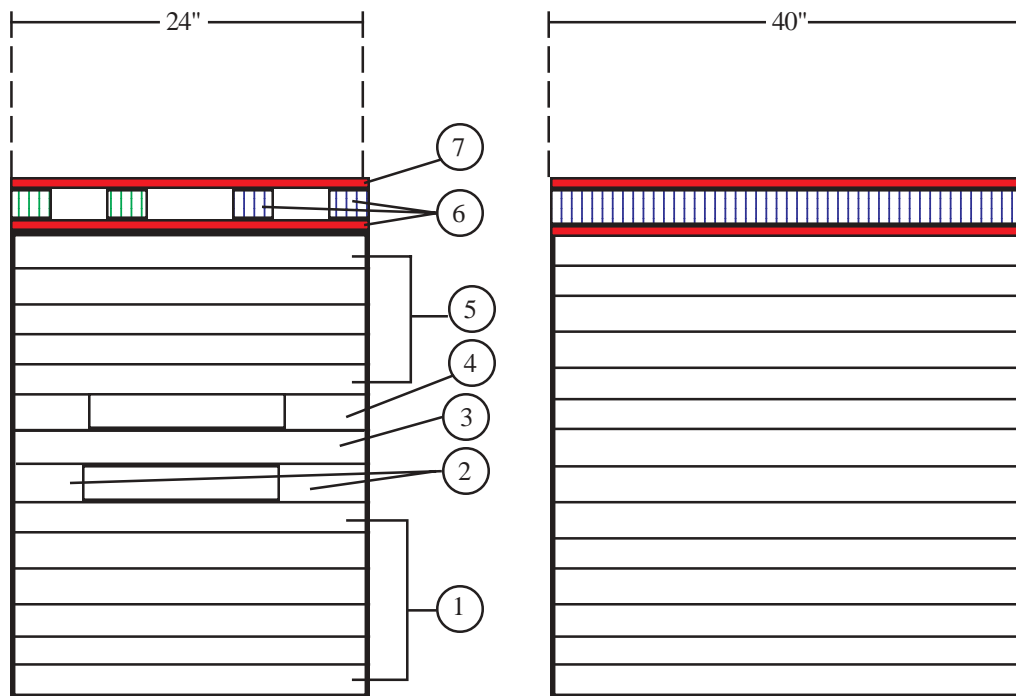

Side view

Front view

- ① Glue six 24- by 40-inch pieces of honeycomb together.
- ② Glue two 8- by 40-inch pieces of honeycomb on each 40 inch side of the six 24- by 40-inch pieces of honeycomb.
- ③ Glue a 24- by 40-inch piece of honeycomb on top of the two 8- by 40-inch pieces of honeycomb.
- ④ Glue two 8- by 40-inch pieces of honeycomb on each 40 inch side of the 24- by 40-inch piece of honeycomb.
- ⑤ Glue five 24- by 40-inch pieces of honeycomb together and on top of the two 8- by 40-inch pieces of honeycomb to form the honeycomb base.
- ⑥ Nail four 4- by 4- by 40-inch pieces of lumber evenly spaced on a 24- by 40-inch piece of 3/4-inch plywood across the 40 inch side of the plywood.
- ⑦ Nail another 24- by 40-inch piece of 3/4-inch plywood on the top of the four 4- by 4- by 40-inch pieces of lumber.

Figure 5-7. Stack 4 prepared



- ⑧ Place the wooden stack on top of the honeycomb stack base.

Note: Do not glue to honeycomb base.

Figure 5-7. Stack 4 prepared (Continued)

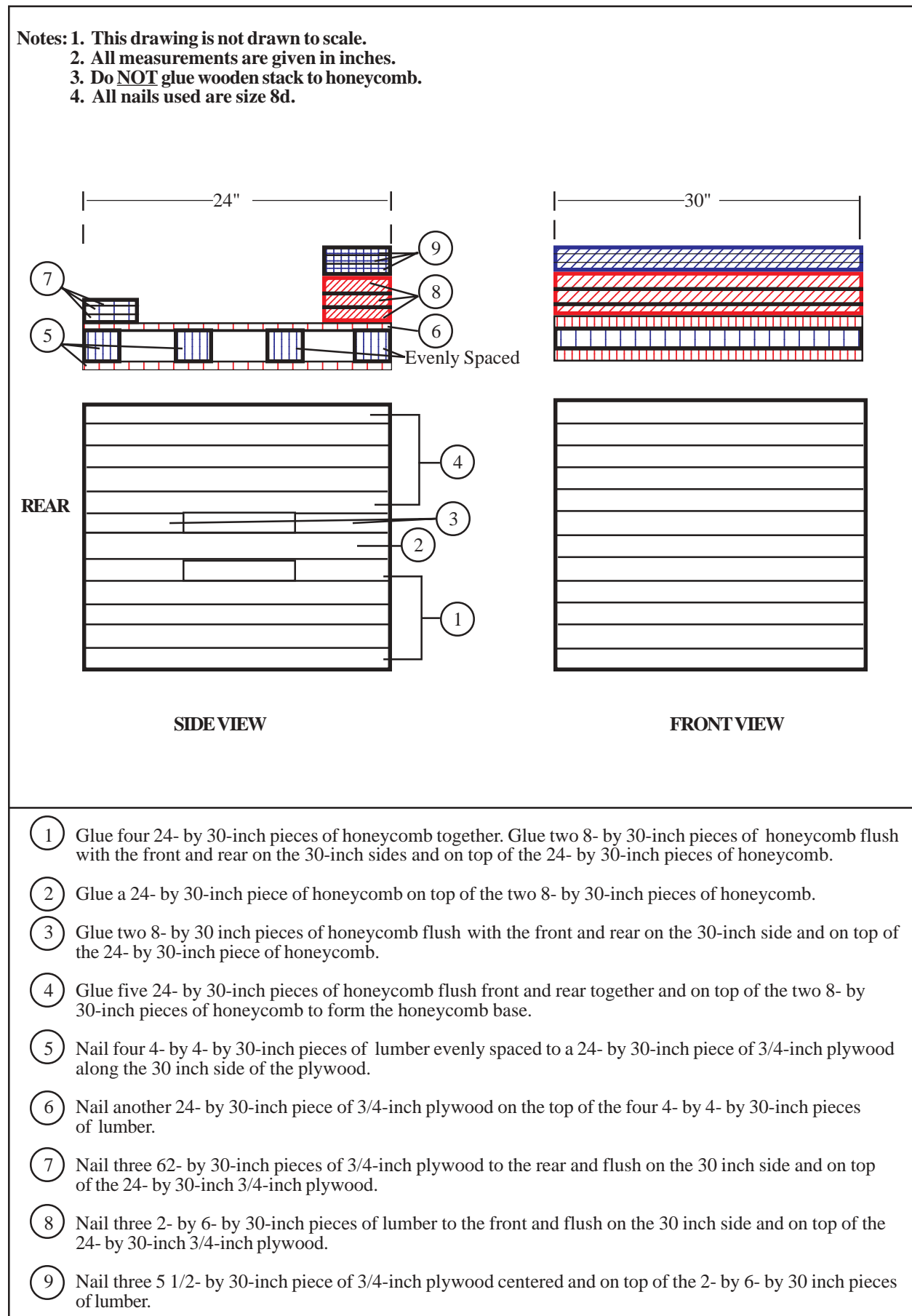
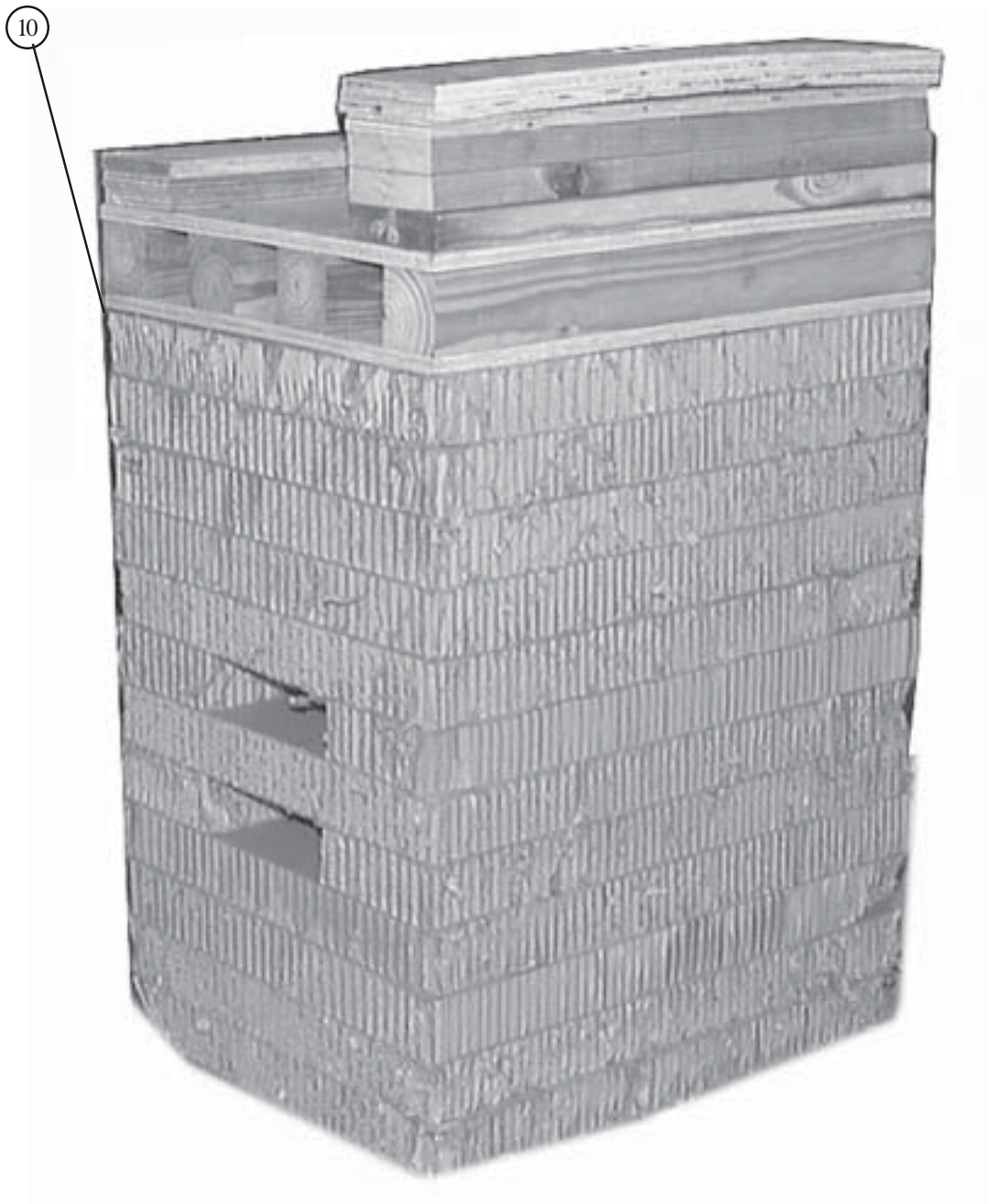

Figure 5-8. Stack 5 prepared



⑩ Place the wooden stack on top of the honeycomb base.

Note: Do not glue to honeycomb base.

Figure 5-8. Stack 5 prepared (Continued)

- Notes: 1. This drawing is not drawn to scale.
2. All measurements are given in inches.

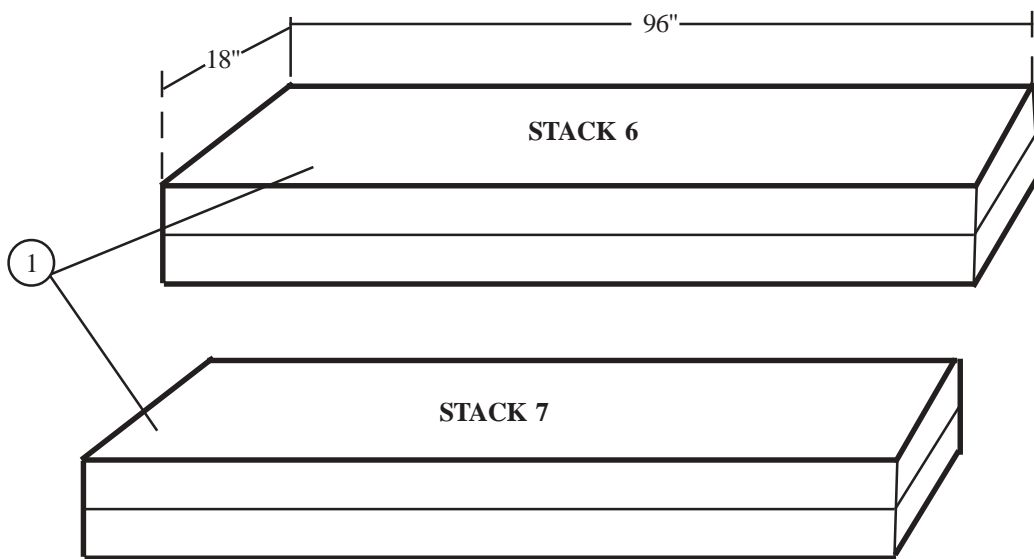

- ① Glue two stacks of two 18- by 96-inch pieces of honeycomb together.

Figure 5-9. Stacks 6 and 7 prepared

5-5. Positioning Honeycomb Stacks

Position the honeycomb stacks as shown in *Figure 5-10*.

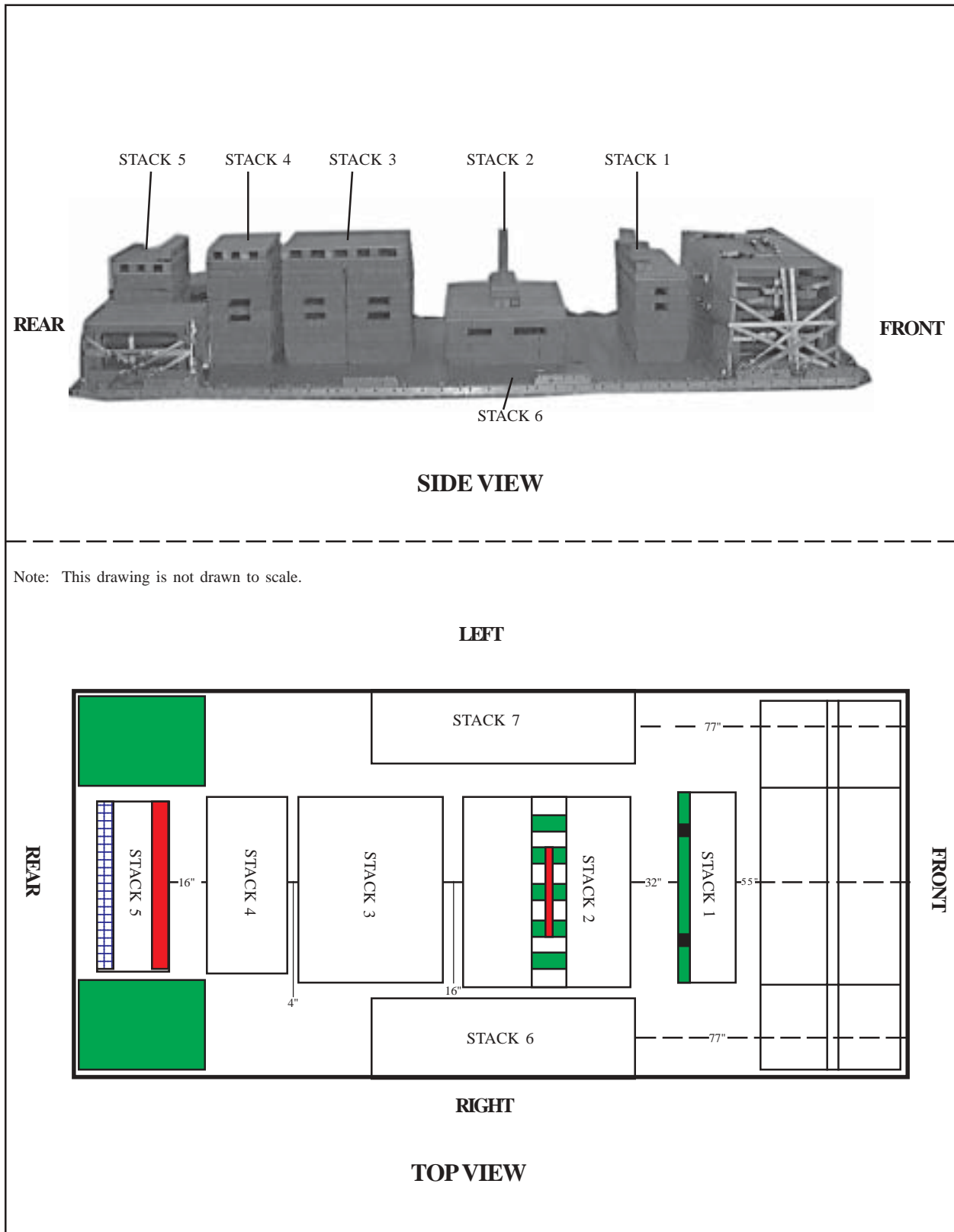

Figure 5-10. Honeycomb stacks positioned on platform

Stack Number	Instructions
1	Position stack 1, centered and 55 inches from the front of the platform edge.
2	Position stack 2, centered and 32 inches from stack 1, (107 inches from the front of the platform edge).
3	Position stack 3, centered and 16 inches from stack 2, (169 inches from the front of the platform edge).
4	Position stack 4, centered and 4 inches from stack 3, (221 inches from the front of the platform edge).
5	Position stack 5, centered and 16 inches from stack 4, (261 inches from the front of the platform edge).
6	Position stack 6, 77 inches from the front of the platform edge and along the right side rail.
7	Position stack 7, 77 inches from the front of the platform edge and along the left side rail.

Figure 5-10. Honeycomb stacks positioned on platform (Continued)

5-6. Preparing Trailer

Prepare the M1095 trailer as shown in *Figure 5-11* and as described below.

- Notes:**
1. Pad and tape all sharp edges that a lashing or sling might make contact with during rigging.
 2. Remove the panel side and supports and place in the panel stowage compartments.
 3. Ensure the tires have no more than 58 PSI tire pressure.

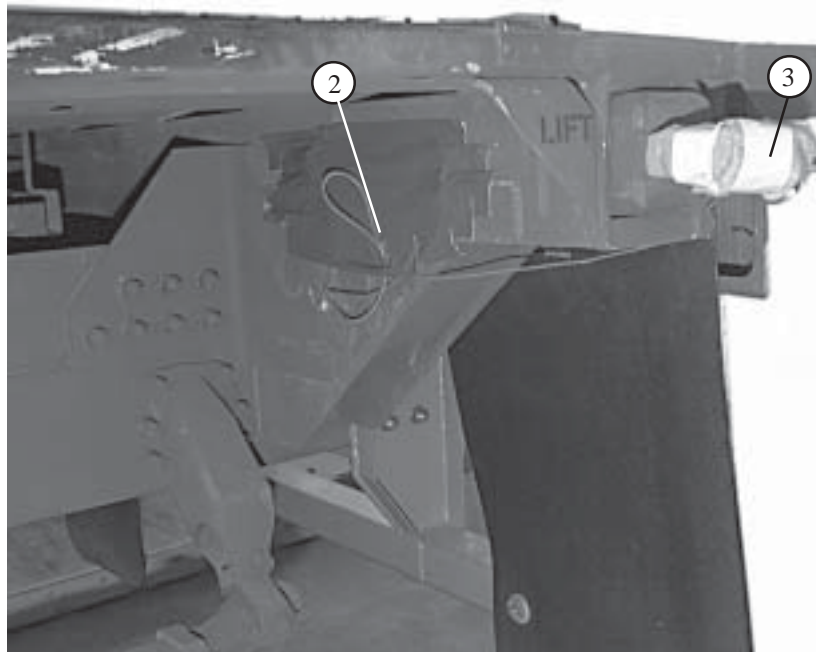
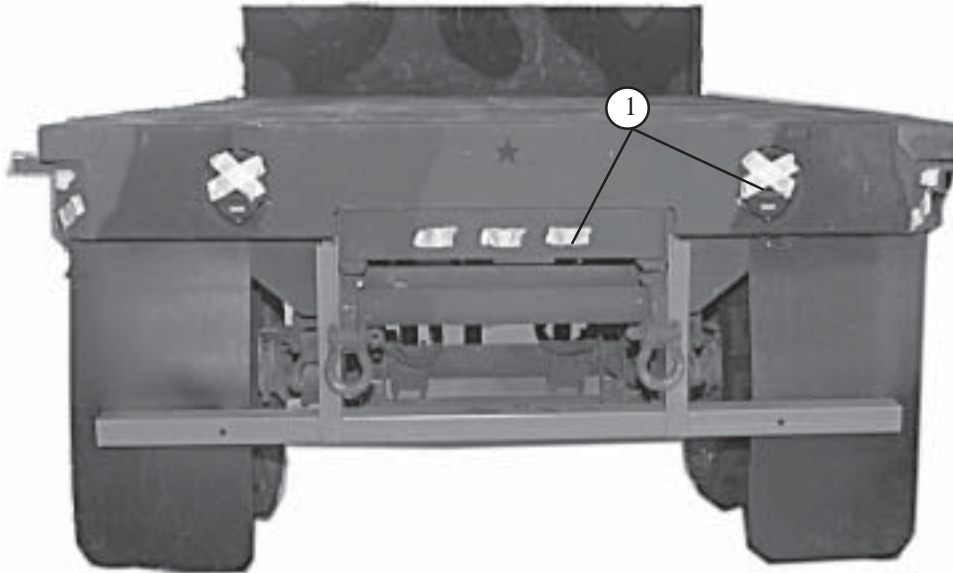

- ① Tape all lights and reflectors.
- ② Extract the lift/sling guides. Ensure the lift/sling guides are in the horizontal position. Insert pins and tape over the pins.
- ③ Pad with cellulose wadding and tape lift/sling guides.

Figure 5-11. Trailer prepared

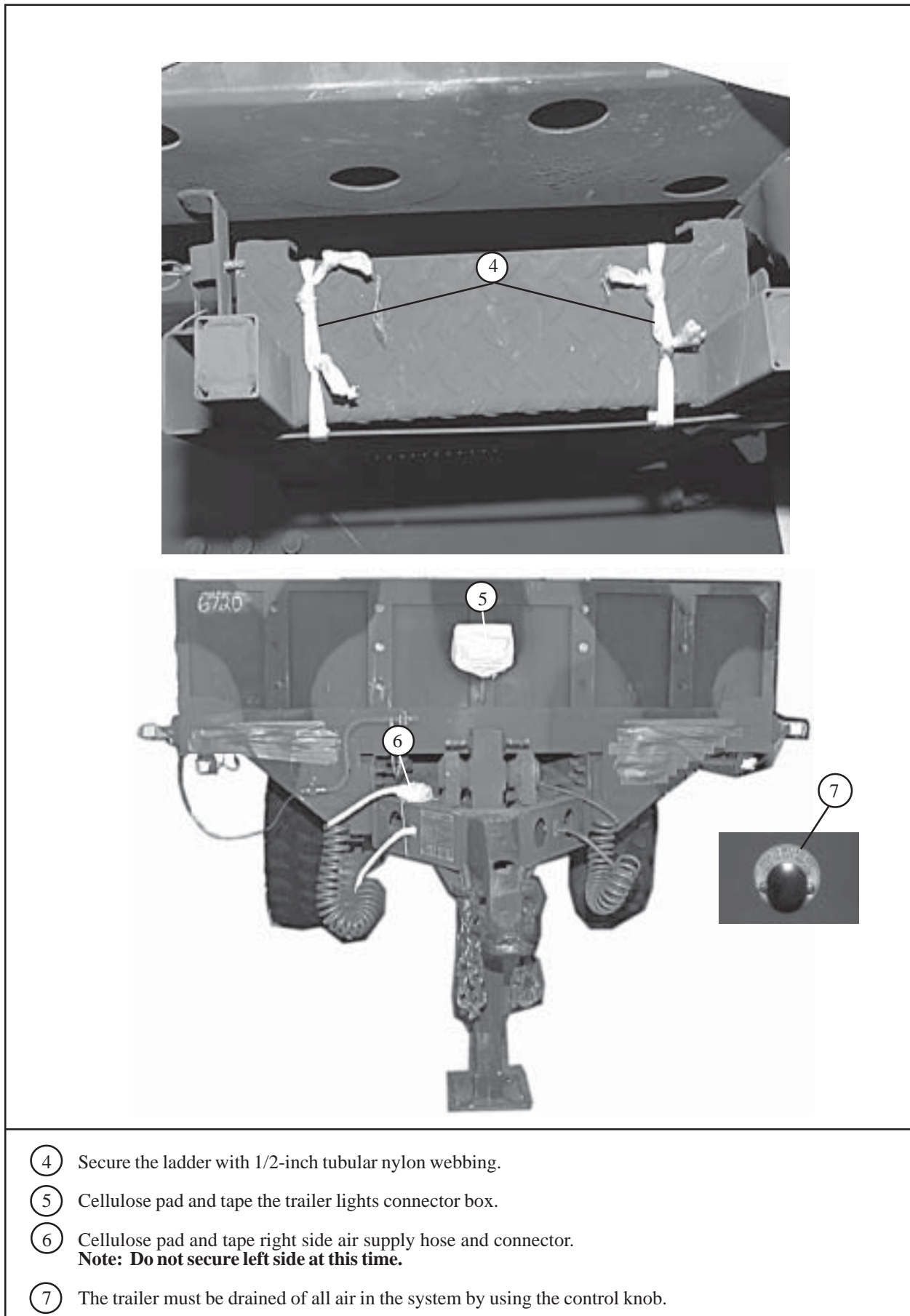
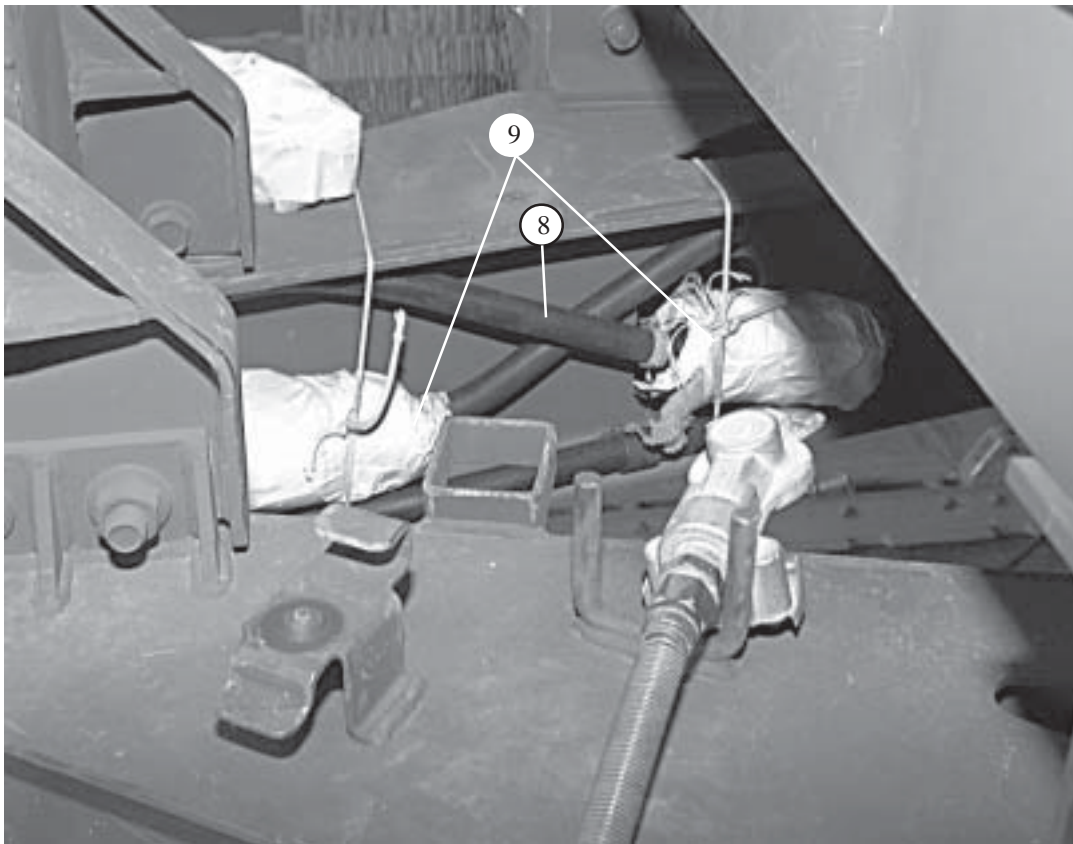

Figure 5-11. Trailer prepared (Continued)



- ⑧ Remove the trailer light cable. Wrap the connectors with cellulose wadding and tape.
- ⑨ Secure with type III nylon cord inside frame behind the towing tongue.

Figure 5-11. Trailer prepared (Continued)

Note: This drawing is not drawn to scale.

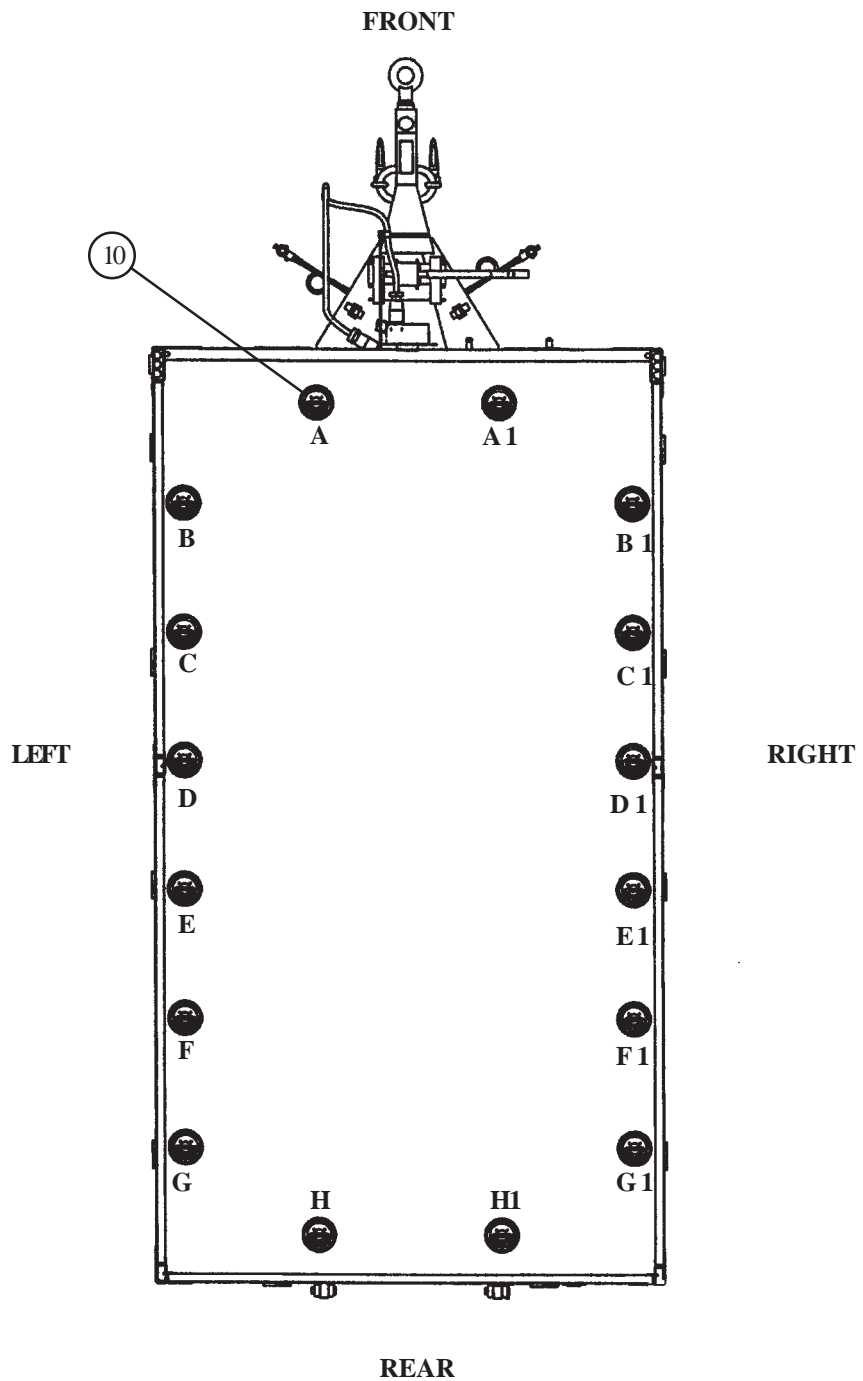

⑩ Label the trailer bed tiedown rings as shown in above diagram.

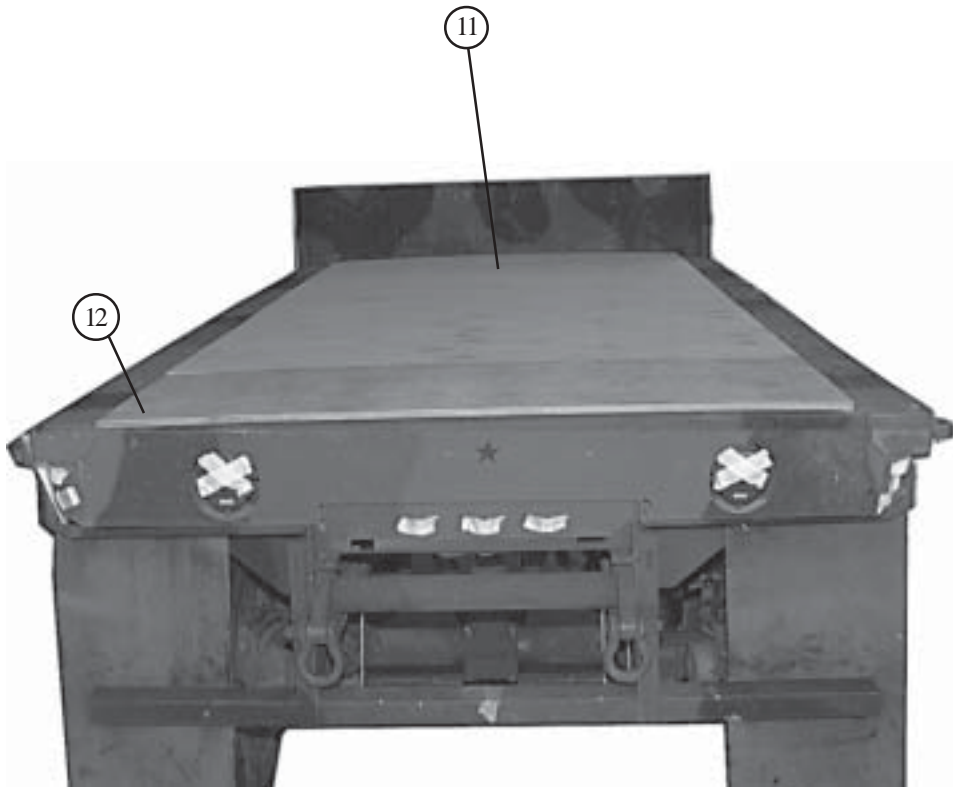

- ⑪ Place three 48- by 79-inch pieces of 3/4-inch plywood centered left to right from the front edge of the trailer bed.
- ⑫ Place a 27- by 79-inch piece of 3/4-inch plywood centered left to right against the 48- by 79-inch piece of 3/4-inch plywood.

Note: These will be used as load spreaders.

Figure 5-11. Trailer prepared (Continued)

5-7. Stowing Trailer Accompanying Load

Stow the trailer accompanying load which consists of three cells of ammunition and the tarp, bow, poles and spreaders in the trailer bed as shown in *Figure 5-12*.

CAUTION
Only ammunition listed in FM 10-500-53/MCRP 4-3.8/TO 13C7-18-41 may be airdropped. Package, mark, and label hazardous material according to AFMAN(I) 24-204/TM 38-250.

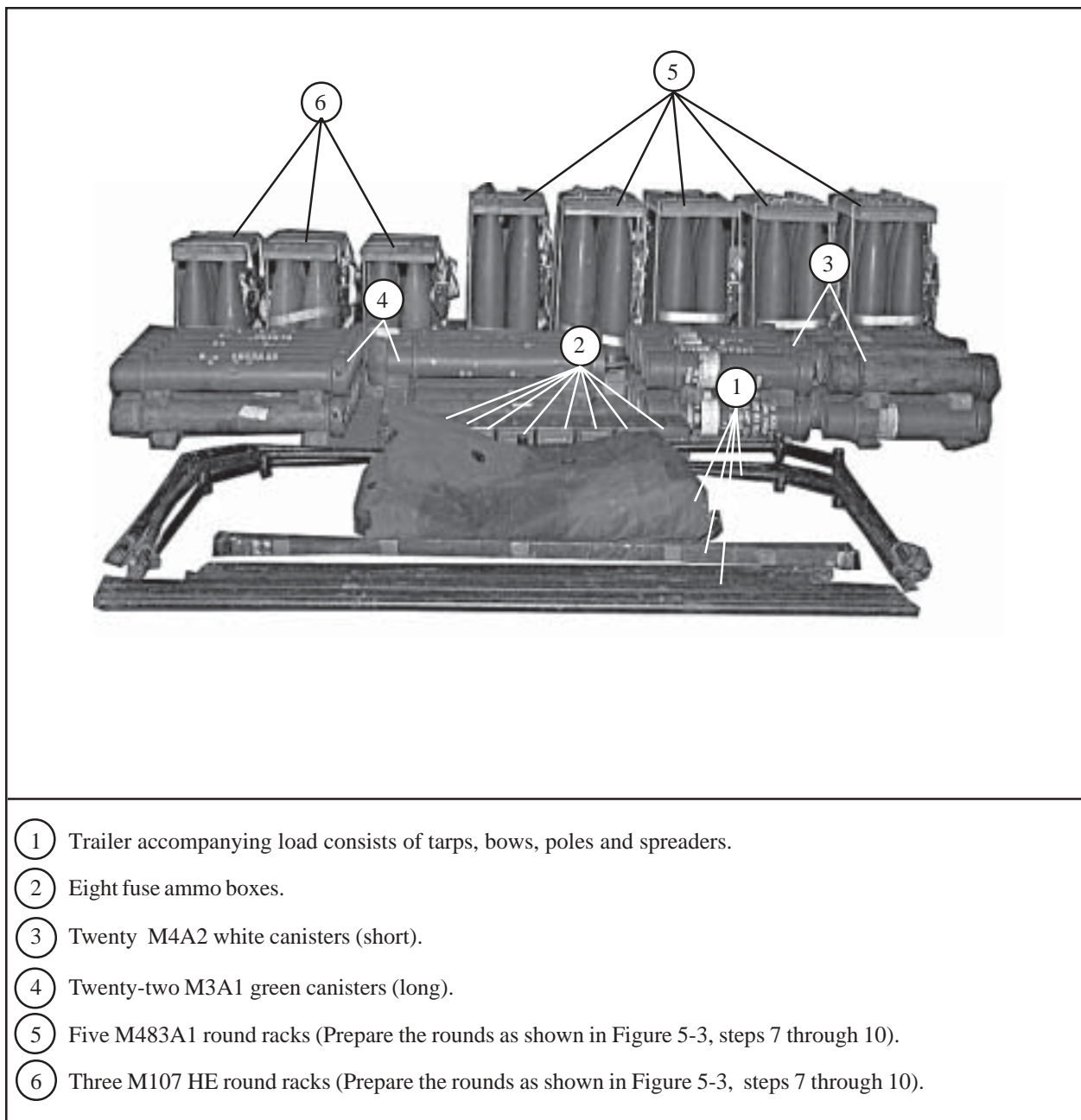
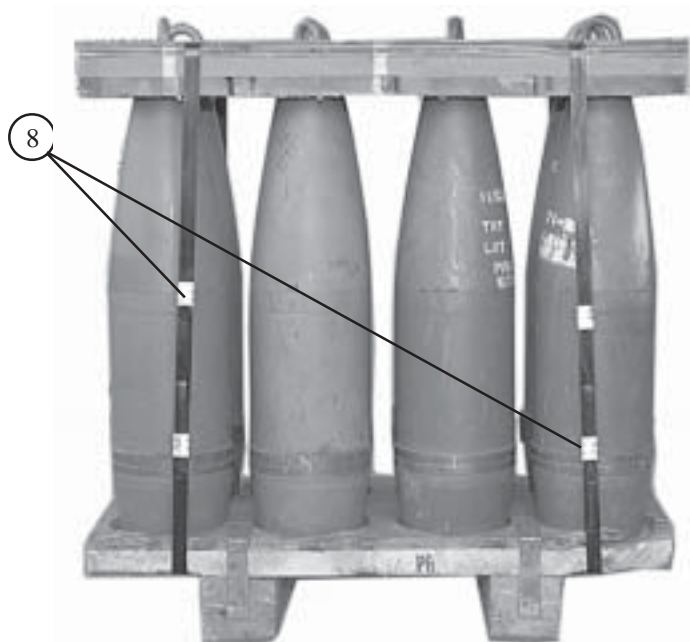
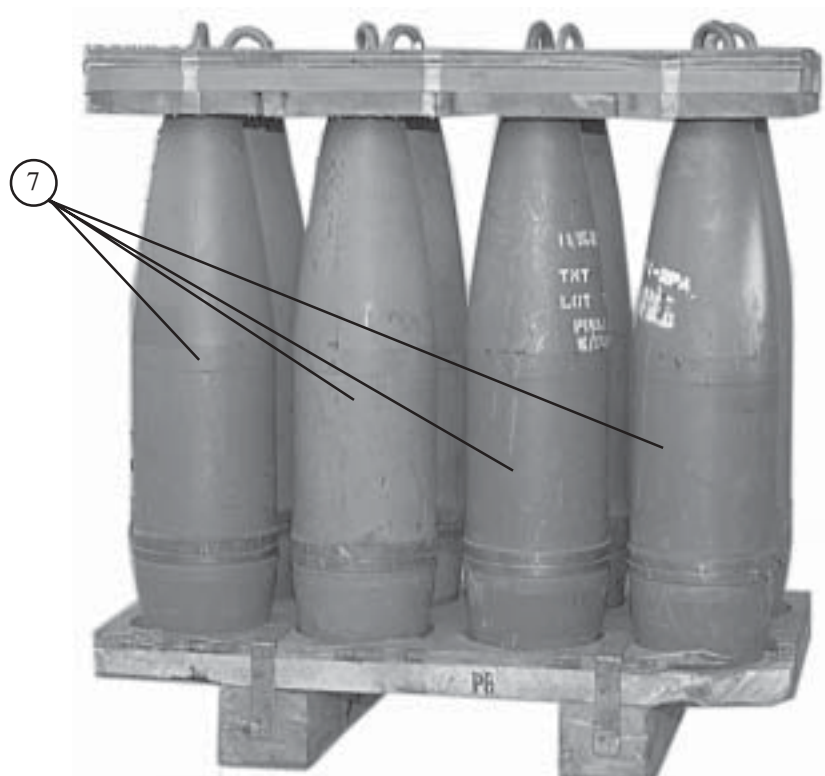
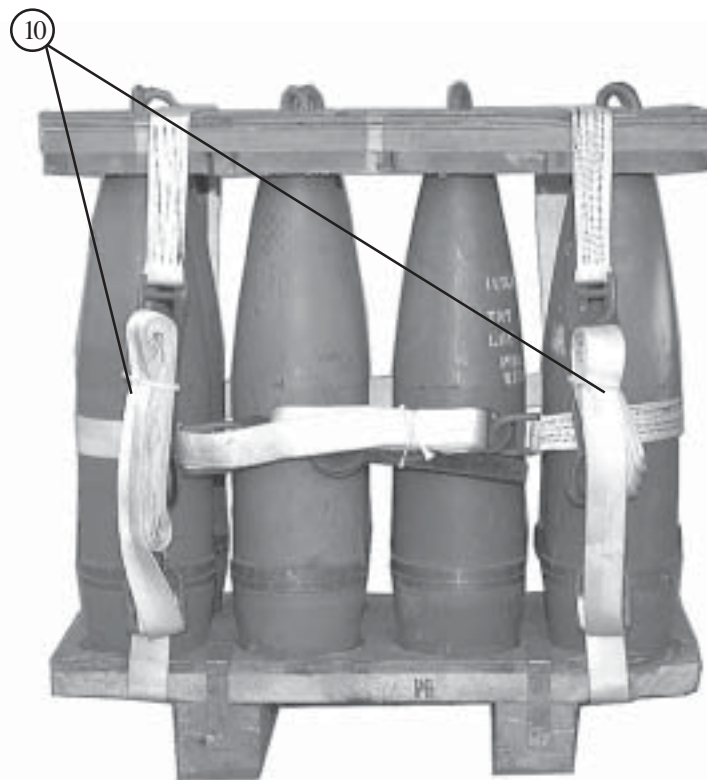
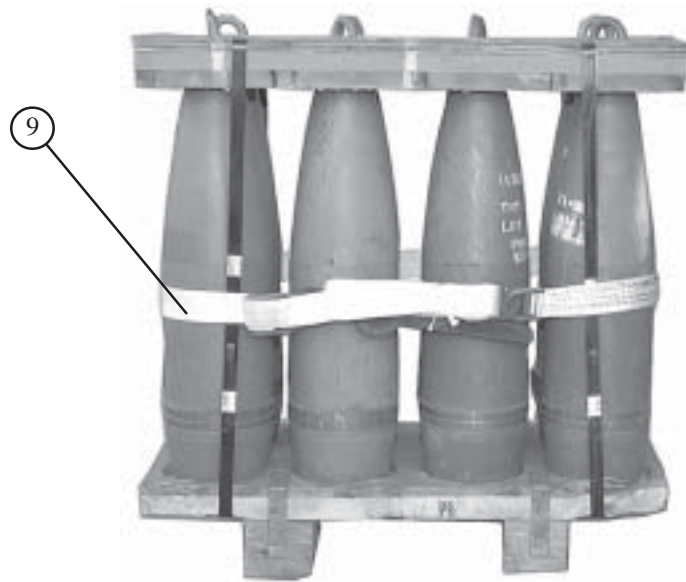

Figure 5-12. Trailer accompanying load stowed



- ⑦ Place eight rounds in wooden shipping rack with footers.
- ⑧ If the banding is on the rounds wooden shipping rack, it may be left on. However it is not needed for rigging.

Figure 5-12. Trailer accompanying load stowed (Continued)



- ⑨ Route and secure a 15-foot lashing around the eight rounds.
- ⑩ Route and secure two 15-foot lashings vertically around the eight rounds.

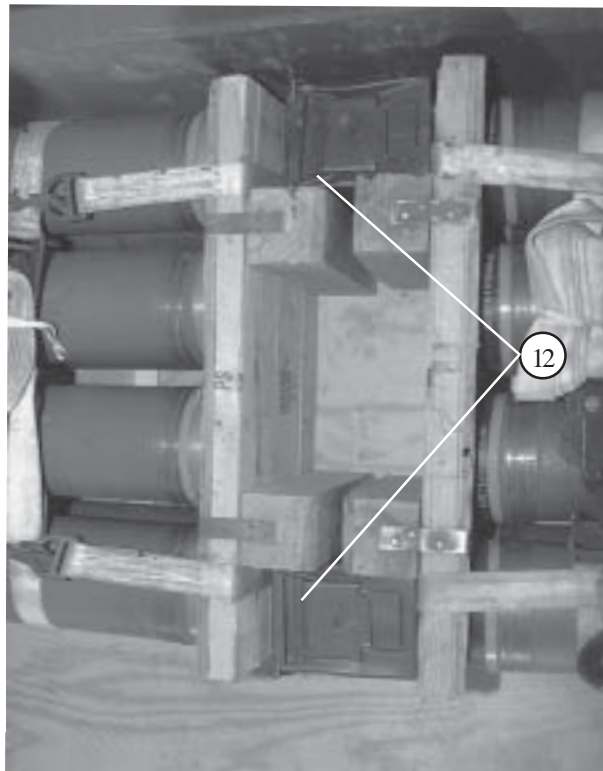
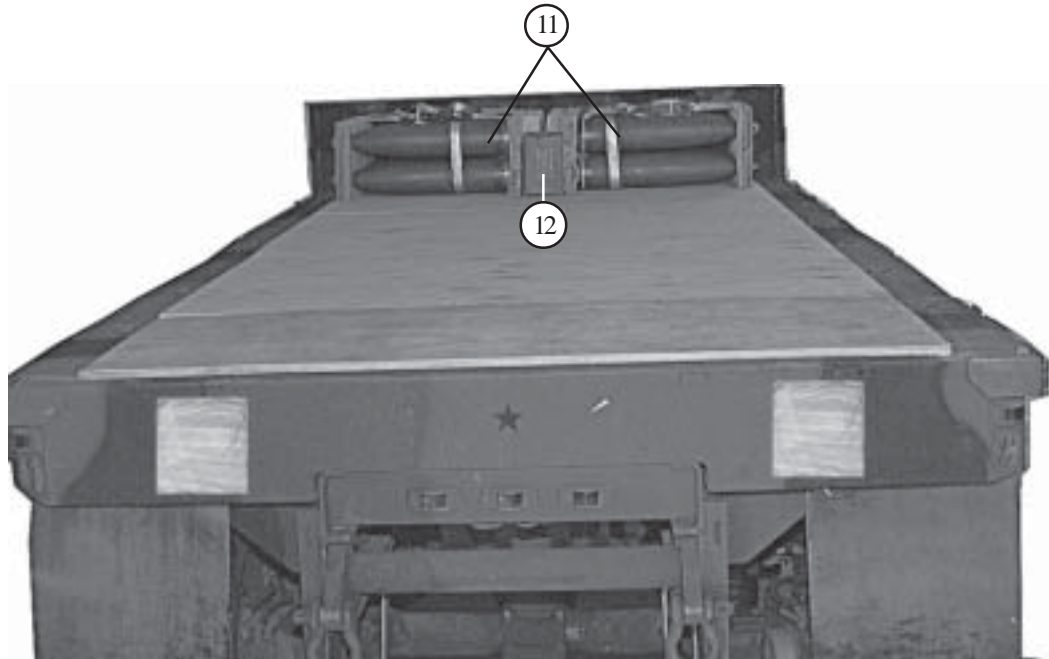

- ⑪ Place two M483A1 racks against the trailer bed front with footers centered.
- ⑫ Place one fuse ammo box each on the outside of the footers of the M483A1 racks.

Figure 5-12. Trailer accompanying load stowed (Continued)

- Notes: 1. This drawing is not drawn to scale.
2. All measurements are given in inches.

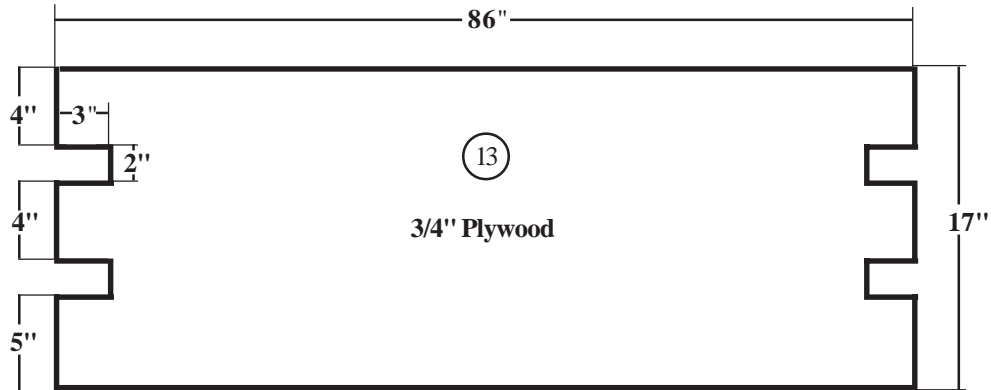

CELL #1 ENDBOARD

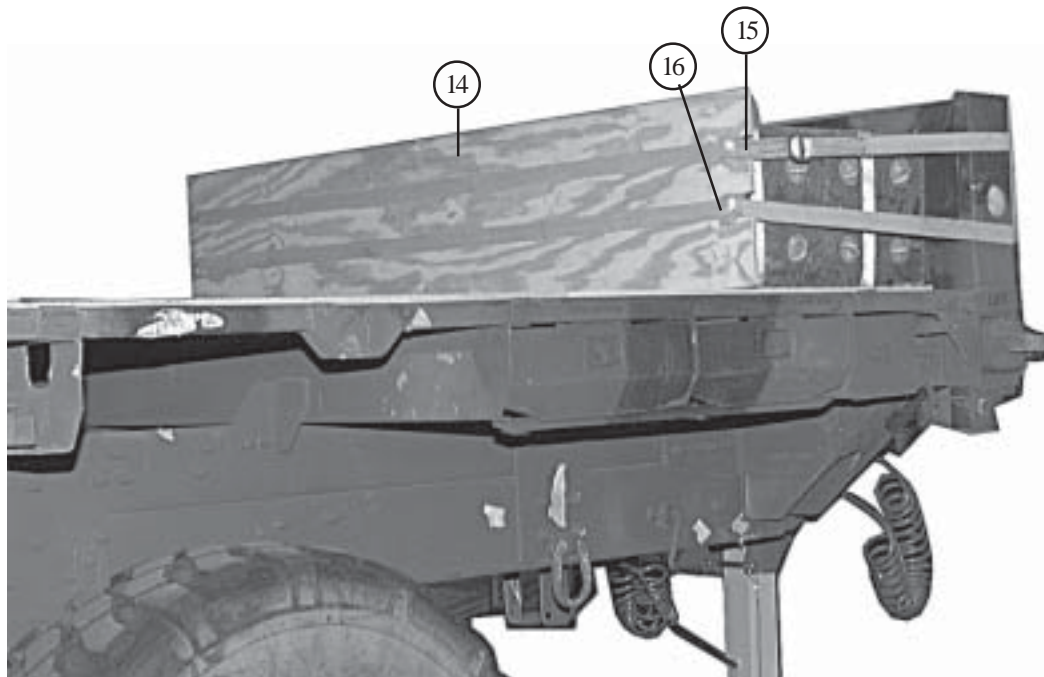

- (13) Construct two endboards as shown in diagram above with 2- by 3-inch deep cutouts.

Note: One endboard will be used on cell #2.

- (14) Place one endboard against the M483A1 racks.
(15) Route a 30-foot lashing through the upper cutouts of cell #1 endboard.
(16) Route a 30-foot lashing through the lower cutouts of cell #1 endboard.

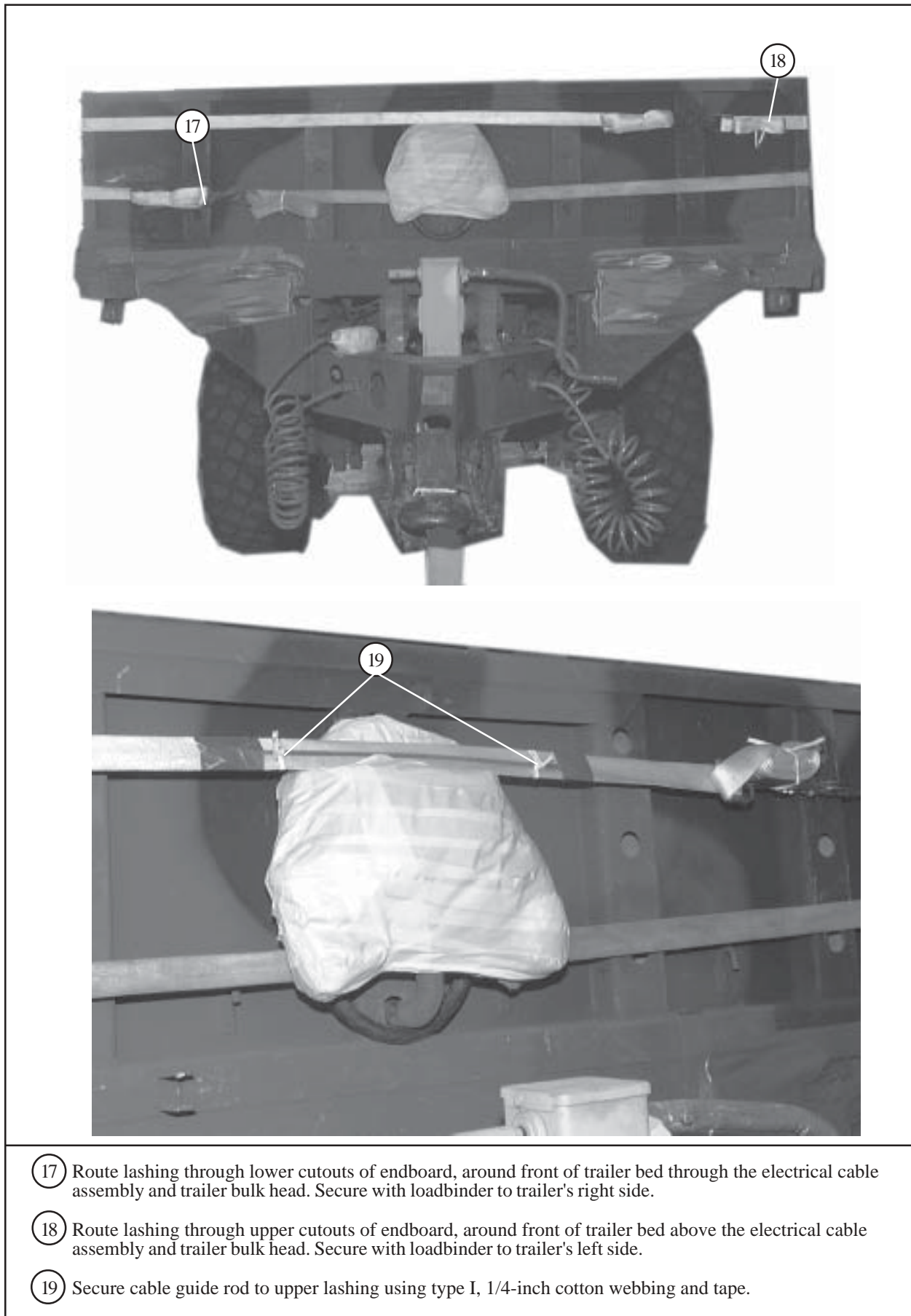
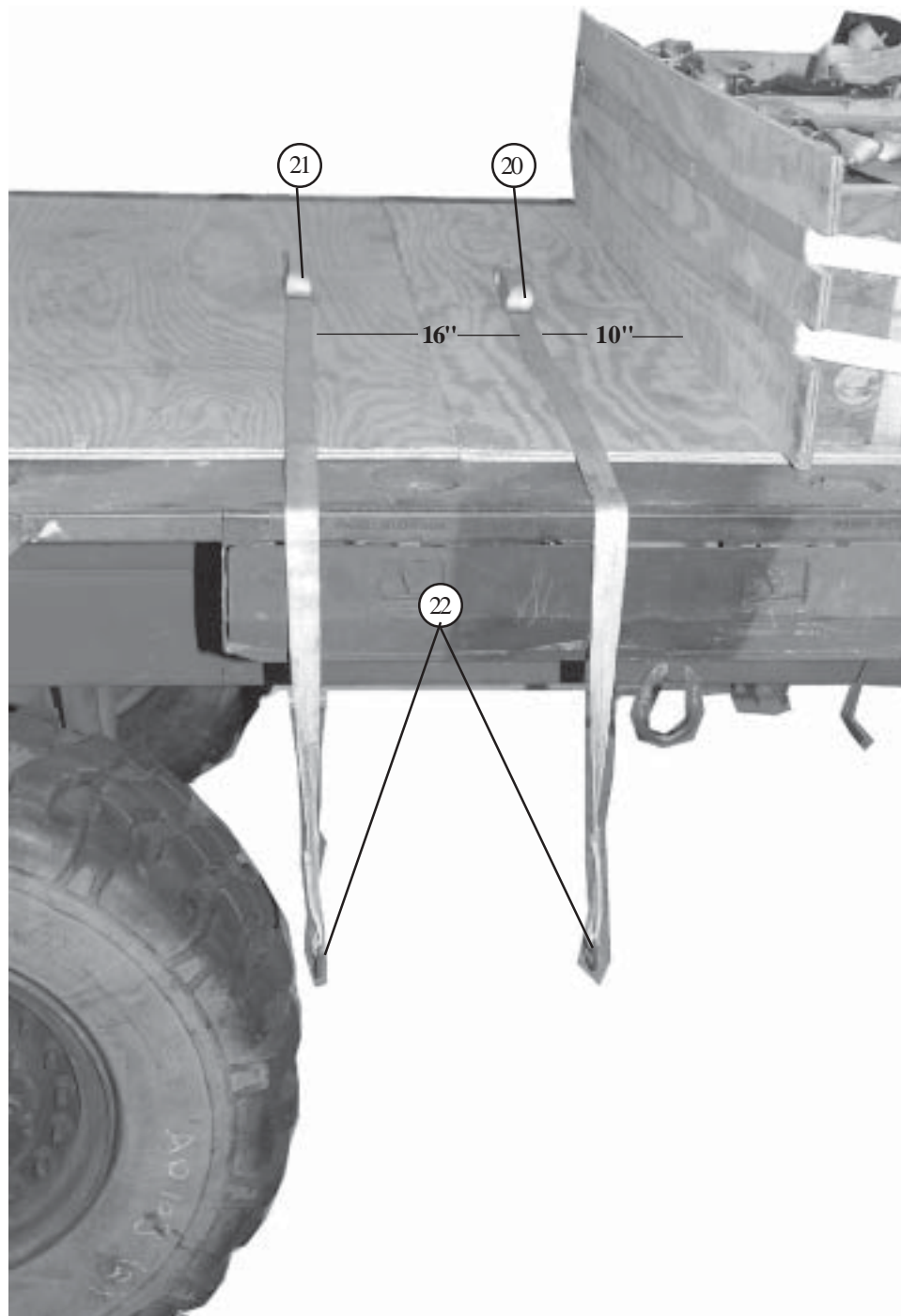
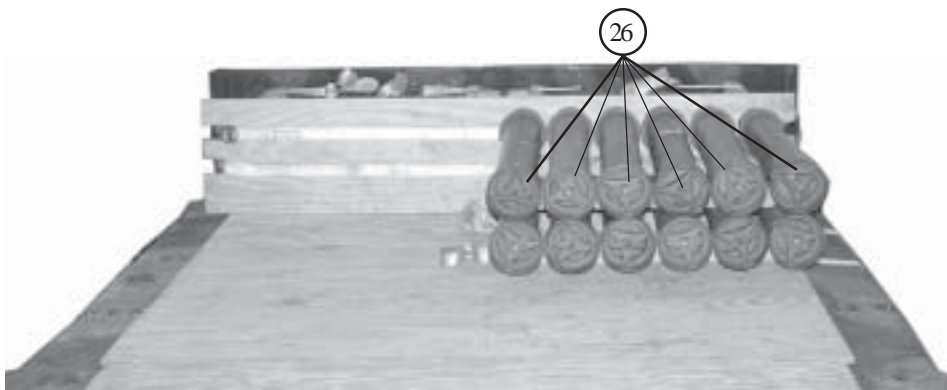
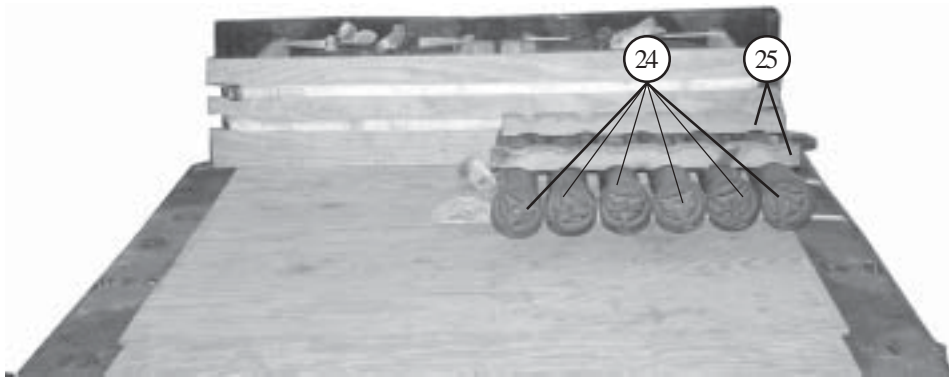

Figure 5-12. Trailer accompanying load stowed (Continued)



- ②① Position a 15-foot lashing 10 inches from the endboard of cell #1 on the right side of the trailer bed.
- ②② Position a second 15-foot lashing 16 inches from the lashing previously positioned.
- ②③ Ensure the lashings D-ring is 36 inches over the edge of the trailer.



- ②3 Position the precut green bag canister stacking lumber on the lashings. Ensure that there is a 1-inch overhang on the 79-inch edge of the plywood.
- ②4 Position six M3A1 green bag canisters (long) on the two pieces of precut green bag canisters stacking lumber.
- ②5 Position two pieces of precut green bag canisters on top of the six green bag canisters.
- ②6 Position six M3A1 green bag canisters (long) on the two pieces of precut green bag canisters stacking lumber.

Figure 5-12. Trailer accompanying load stowed (Continued)

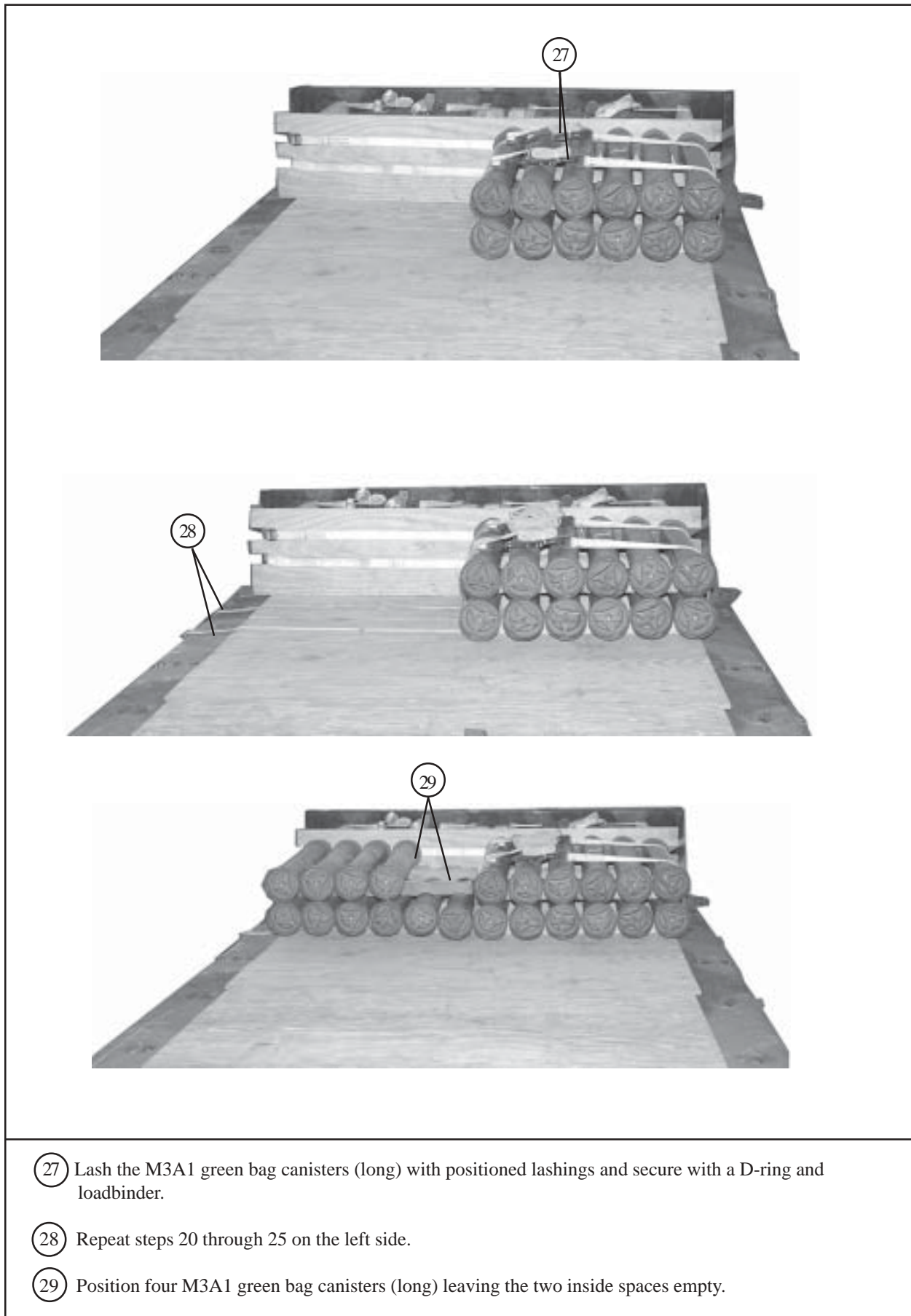

- 27 Lash the M3A1 green bag canisters (long) with positioned lashings and secure with a D-ring and loadbinder.
- 28 Repeat steps 20 through 25 on the left side.
- 29 Position four M3A1 green bag canisters (long) leaving the two inside spaces empty.

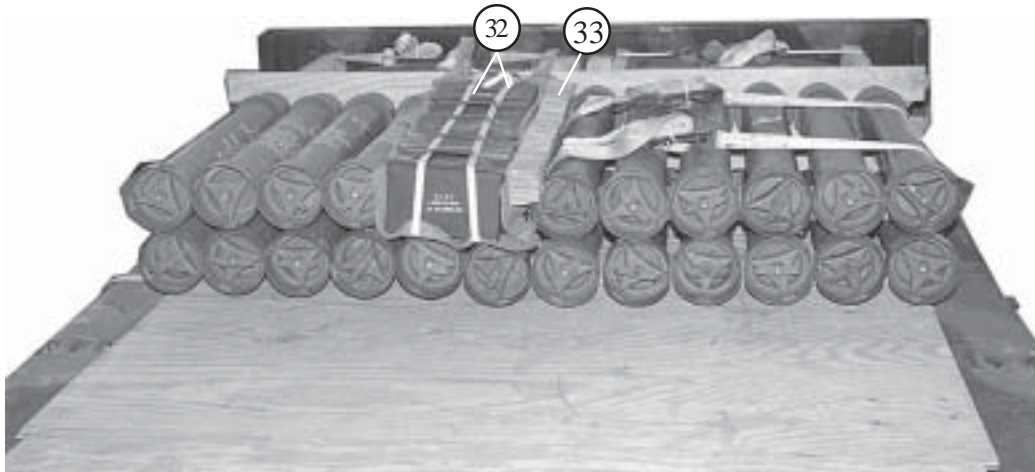
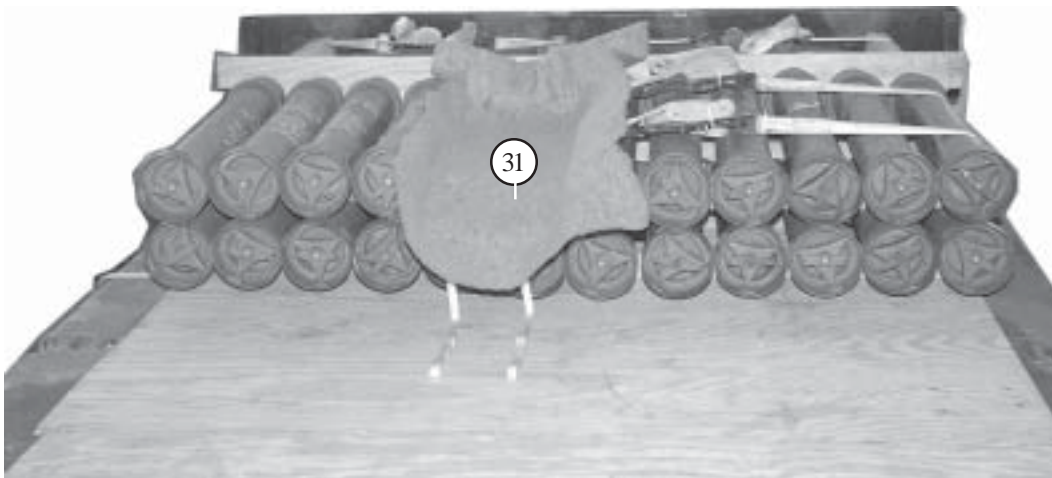
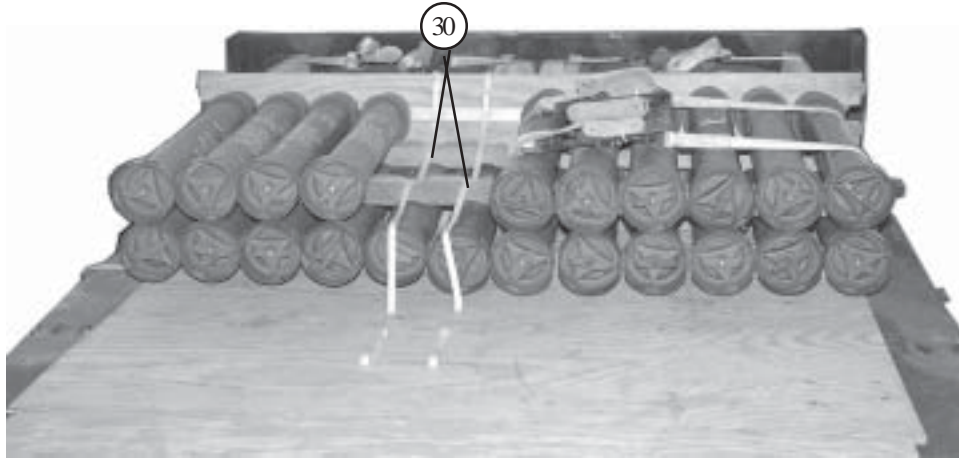

- ③① Position two 120-inch lengths of 1/2-inch tubular nylon webbing across the empty rack spaces.
- ③② Place a 36- by 50-inch piece of felt on top of the two lengths.
- ③③ Position six fuse ammo boxes on the felt. Secure with the positioned 1-inch tubular nylon webbing through the carrying handles.
- ③④ Fill the empty space between the felt and the trailer's right side of the M3A1 green bag canisters stack with pieces of honeycomb.

Figure 5-12. Trailer accompanying load stowed (Continued)

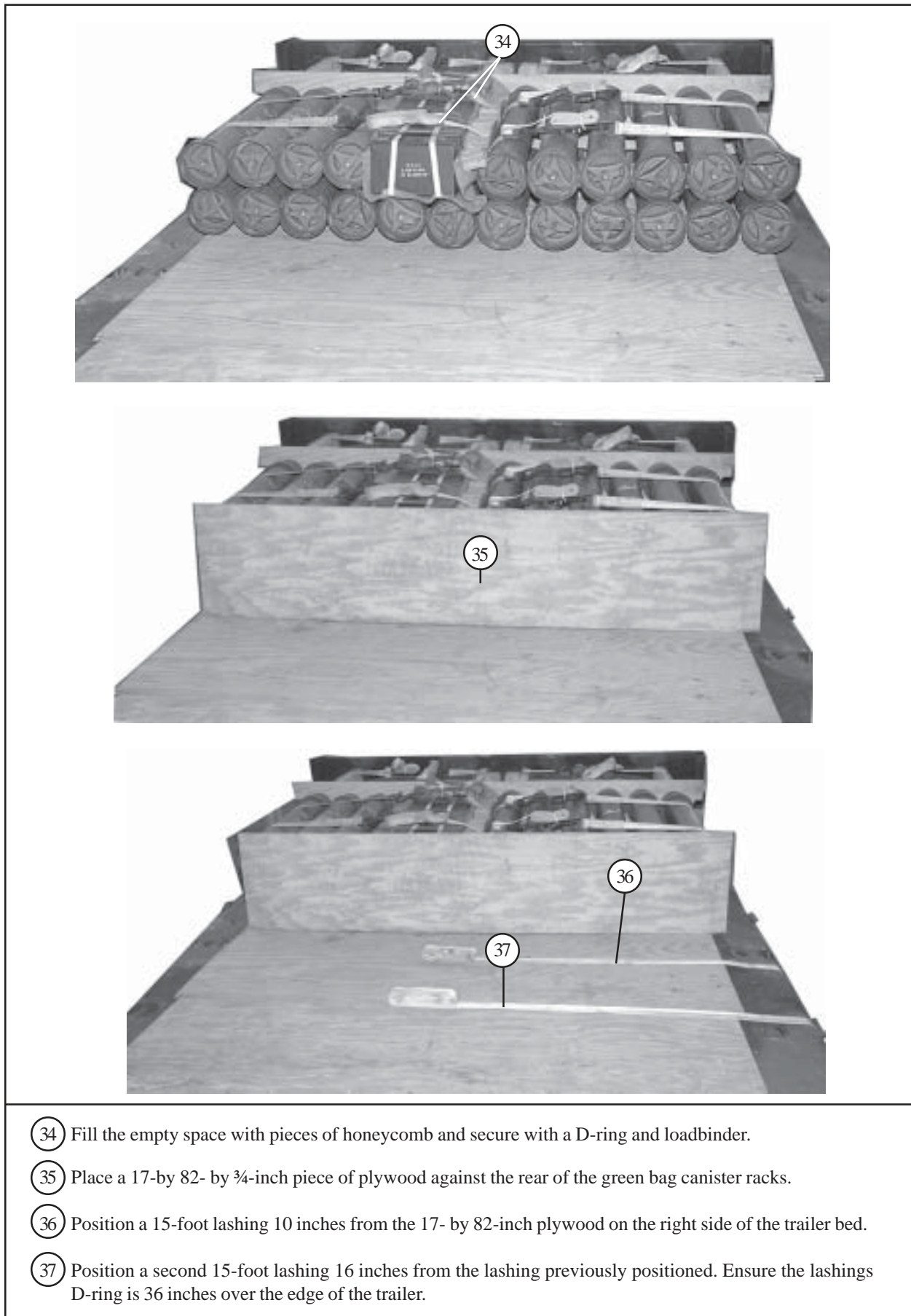

- (34) Fill the empty space with pieces of honeycomb and secure with a D-ring and loadbinder.
- (35) Place a 17-by 82- by $\frac{3}{4}$ -inch piece of plywood against the rear of the green bag canister racks.
- (36) Position a 15-foot lashing 10 inches from the 17- by 82-inch plywood on the right side of the trailer bed.
- (37) Position a second 15-foot lashing 16 inches from the lashing previously positioned. Ensure the lashings D-ring is 36 inches over the edge of the trailer.

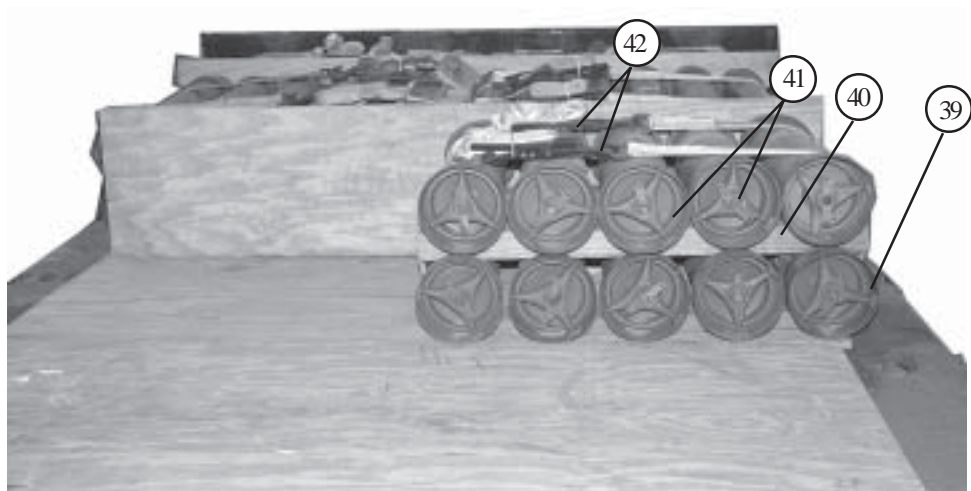

- ③⑧ Position the precut white bag canister stacking lumber on the lashings. Ensure that there is a 1-inch overhang on the 79-inch edge of the plywood.
- ③⑨ Position five M4A2 white bag canisters (short) on top of the two pieces of precut white bag canister stacking lumber.
- ④⑩ Position two pieces of precut white bag canisters stacking lumber on top of the five M4A2 white bag canisters (short).
- ④① Position five M4A2 white bag canisters (short) on top of the two pieces of precut white bag canister stacking lumber.
- ④② Lash the M4A2 white bag canisters (short) with positioned lashings and secure with a D-ring and loadbinder.

Figure 5-12. Trailer accompanying load stowed (Continued)

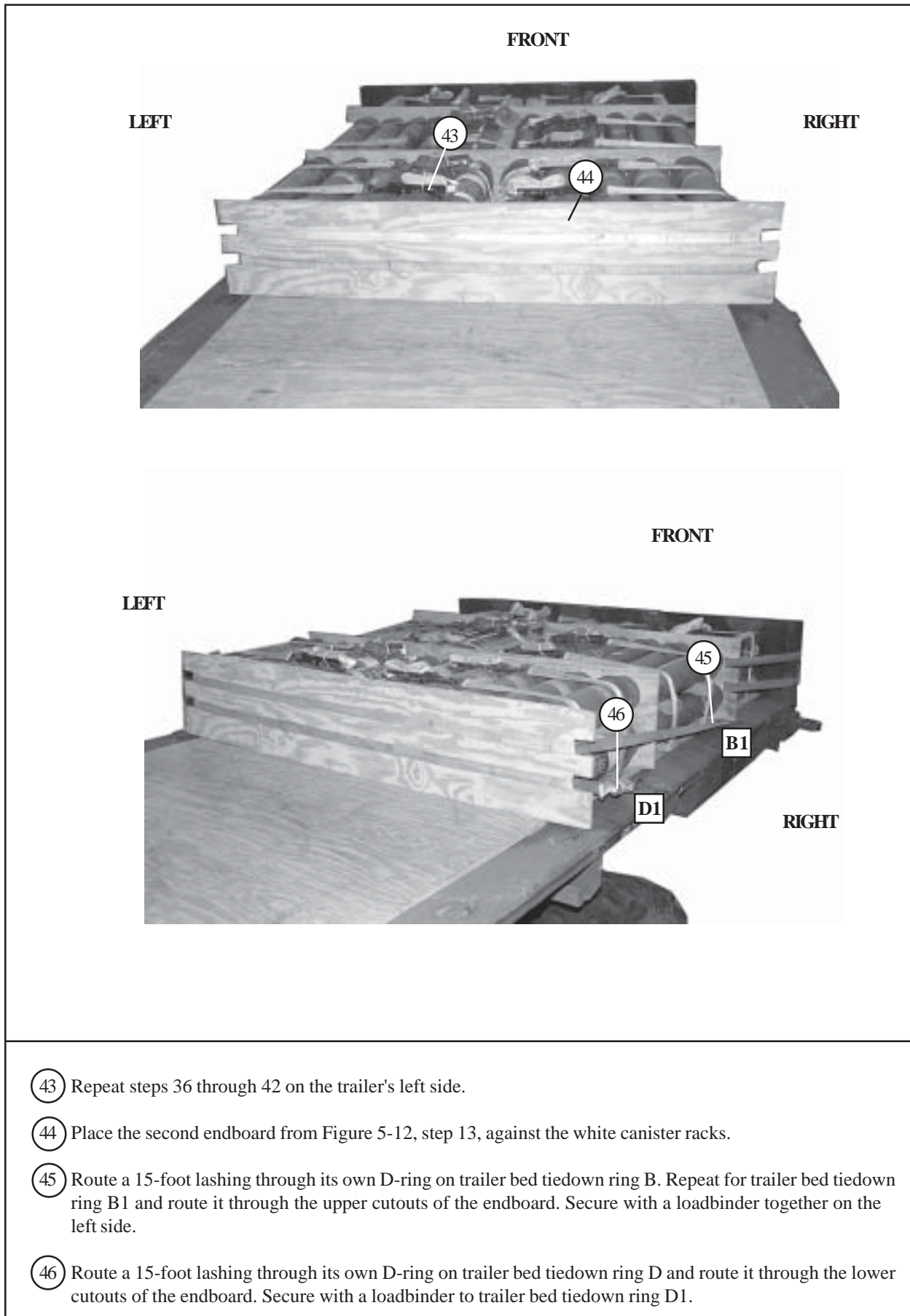
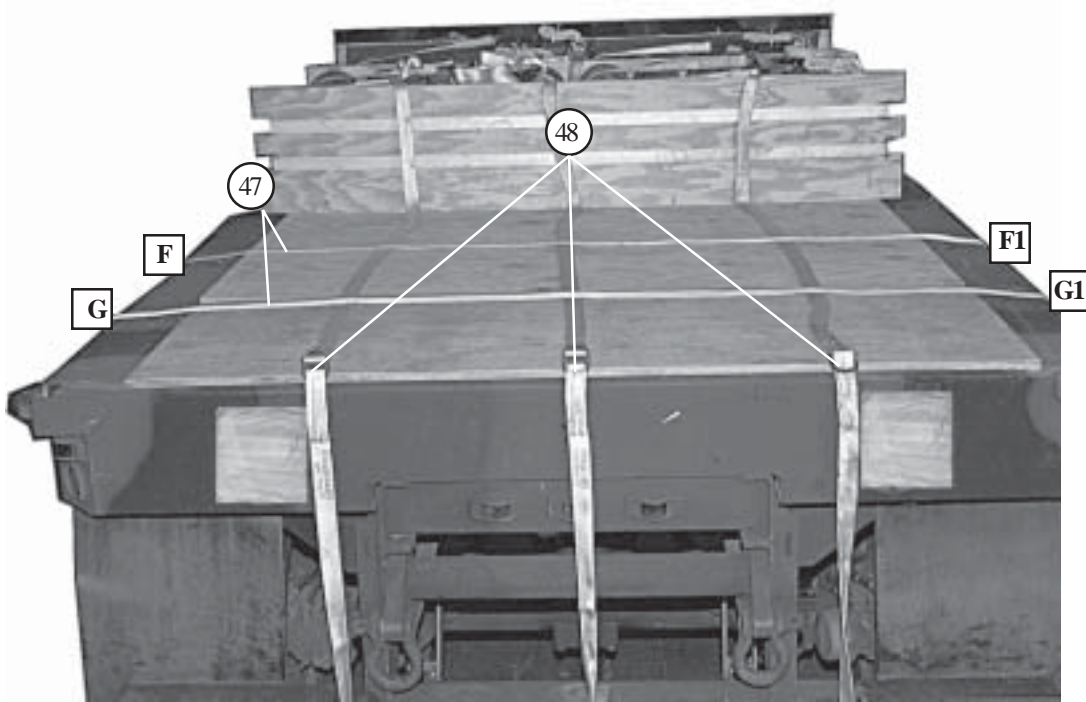

Figure 5-12. Trailer accompanying load stowed (Continued)



- (47) Position three 30-foot lashings lengthwise to the rear of cell #2 with the D-rings at the rear edge of the plywood.
- (48) Position two 15-foot lashings across the bed approximately at F, F1, G, and G1 bed-rings.

Figure 5-12. Trailer accompanying load stowed (Continued)

- Notes: 1. This drawing is not drawn to scale.
 2. All measurements are given in inches.

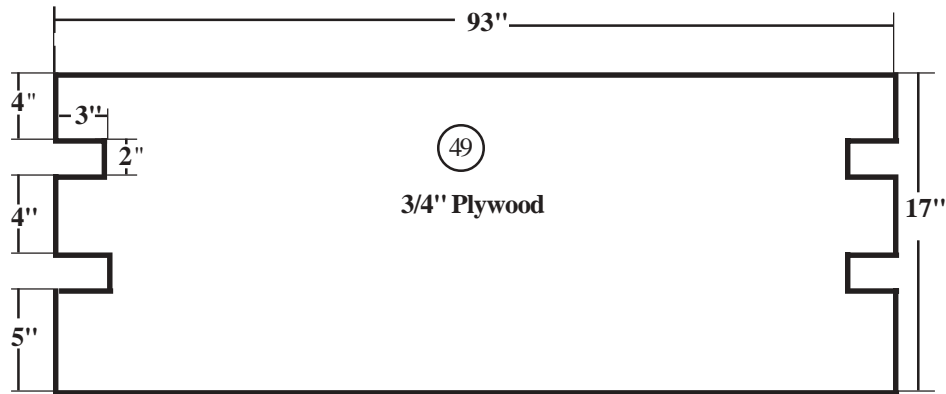

Endboard for cell #3

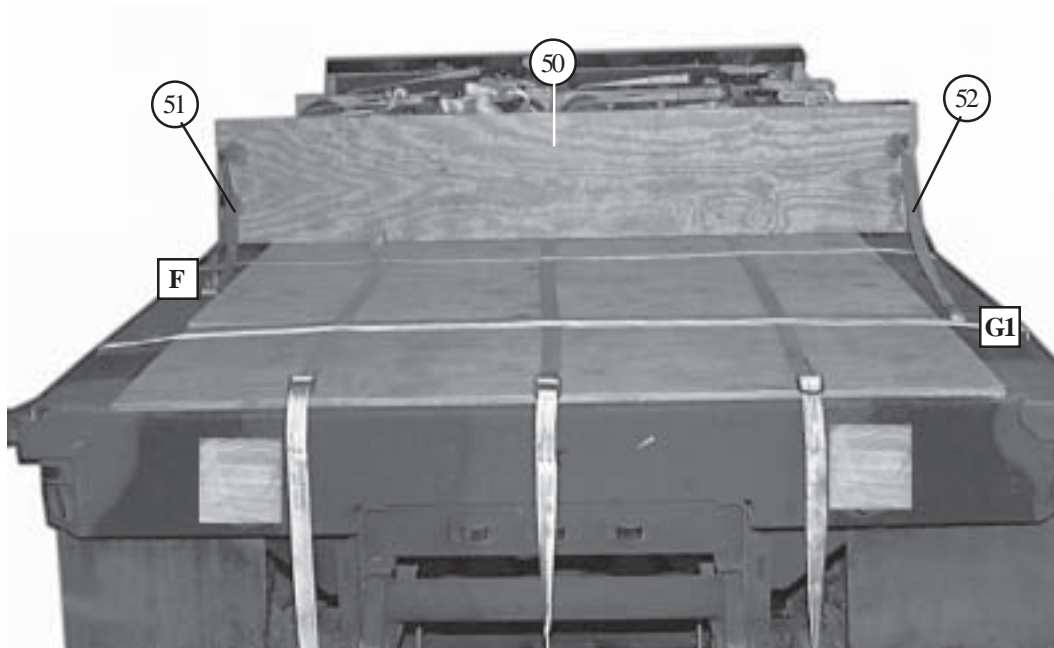

- (49) Construct three endboards as shown in diagram above with 2- by 3-inch deep cutouts.
- (50) Place an endboard against cell #2.
- (51) Route a 15-foot lashing through its own D-ring on trailer bed tiedown ring F and through the lower cutouts of the endboard.
Note: Do NOT tighten loadbinder at this time. Step 64 will complete this step.
- (52) Route a 15-foot lashing through its own D-ring on trailer bed tiedown ring G1 and through the upper cutouts of the endboard.
Note: Do NOT tighten loadbinder at this time. Step 65 will complete this step.

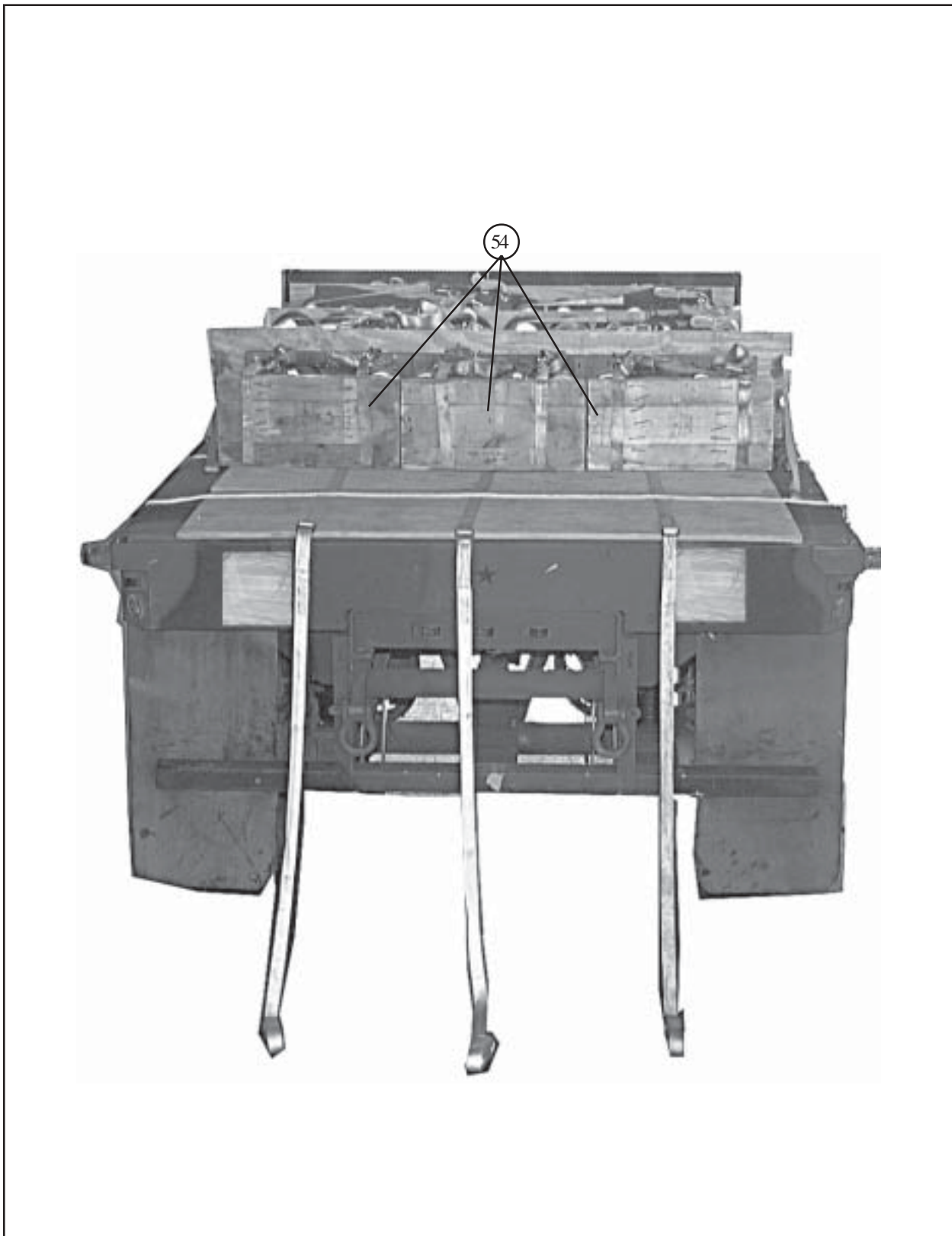

- ⑤3 Prepare three M107 HE racks according to Figure 5-12, steps 7 through 10. Remove footers from shipping racks base.
- ⑤4 Position the three M107 HE racks top toward front of trailer centered and against the endboard.

Figure 5-12. Trailer accompanying load stowed (Continued)

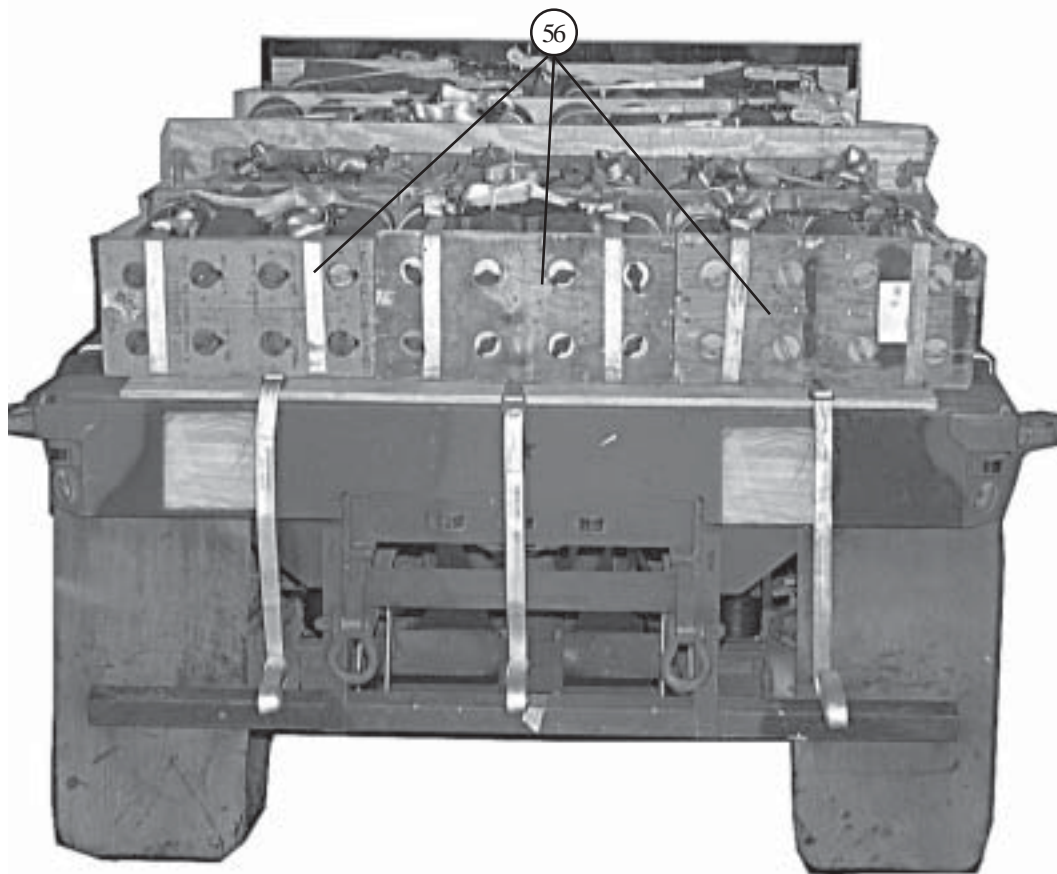

- 55 Prepare three M483A1 racks according to Figure 5-12, steps 7 through 10. Remove footers from shipping racks base.
- 56 Position the three M483A1 racks with footers against the M107 HE racks .

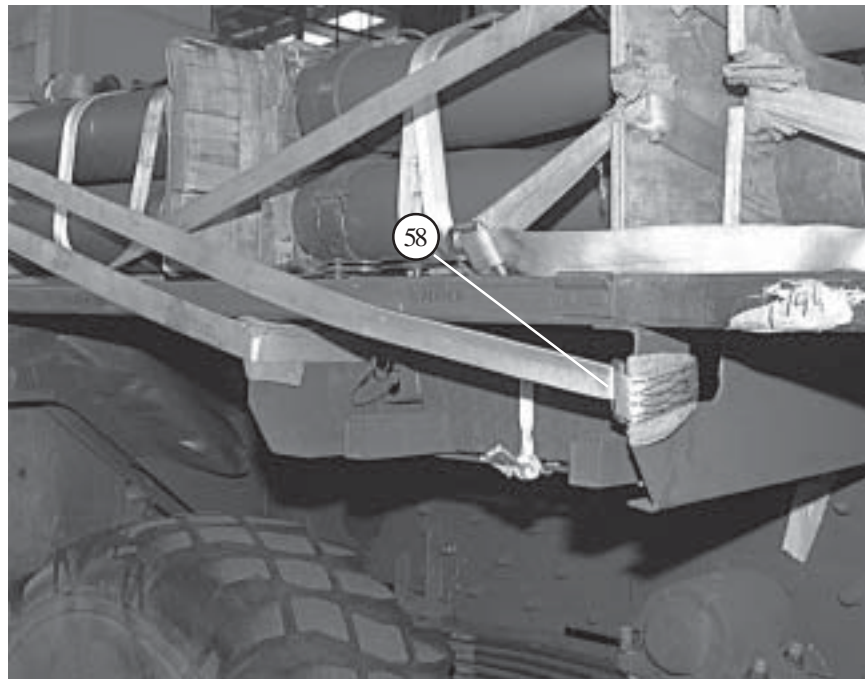
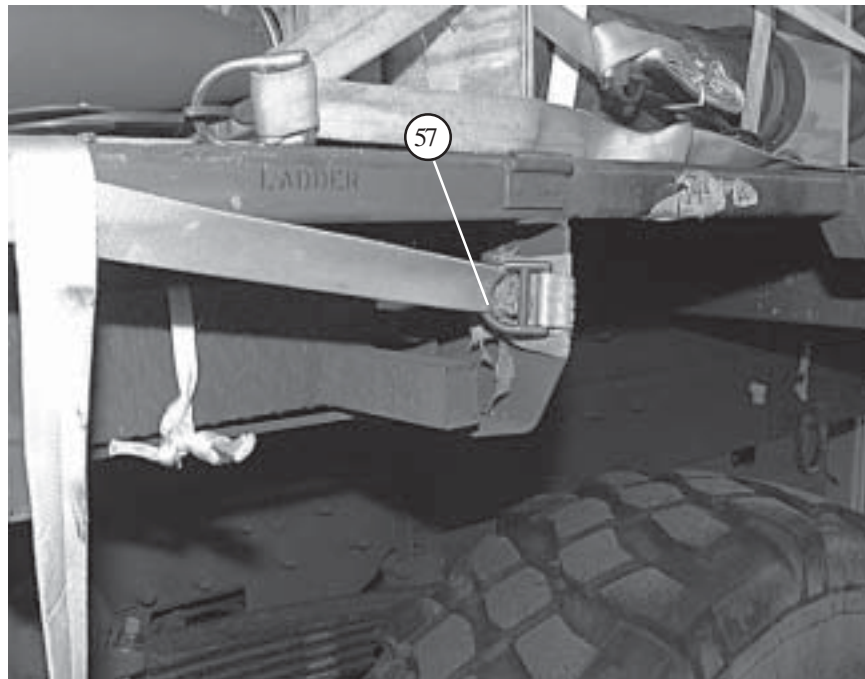

- ⑤7 Route a 15-foot lashing through hole in front of the ladder frame on the right side and back through it's own D-ring.
- ⑤8 Route a 15-foot lashing through hole in front of the ladder frame on the left side and back through it's own D-ring.

Figure 5-12. Trailer accompanying load stowed (Continued)

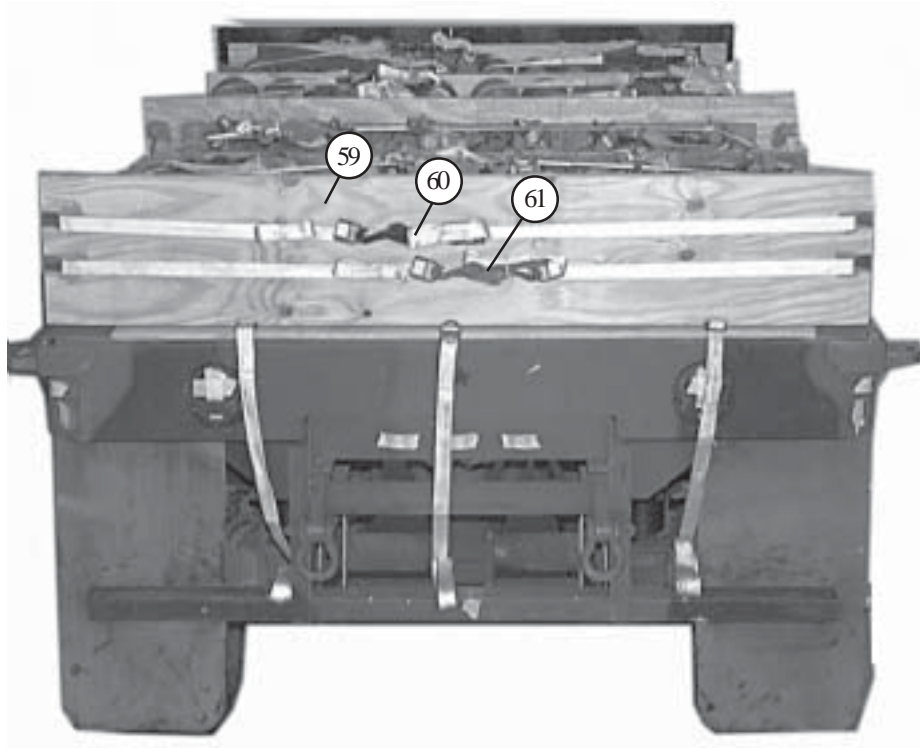

- ⑤⑨ Place two endboards from step 49, to the rear and against cell #3.
- ⑥⑩ Route both lashings through the upper cutouts of the rear endboards and secure with loadbinder in the rear.
- ⑥⑪ Route a 30-foot lashing to the inside of the rear ladder frame and through the lower cutouts of the rear endboards. Secure with loadbinder in the rear.

Figure 5-12. Trailer accompanying load stowed (Continued)

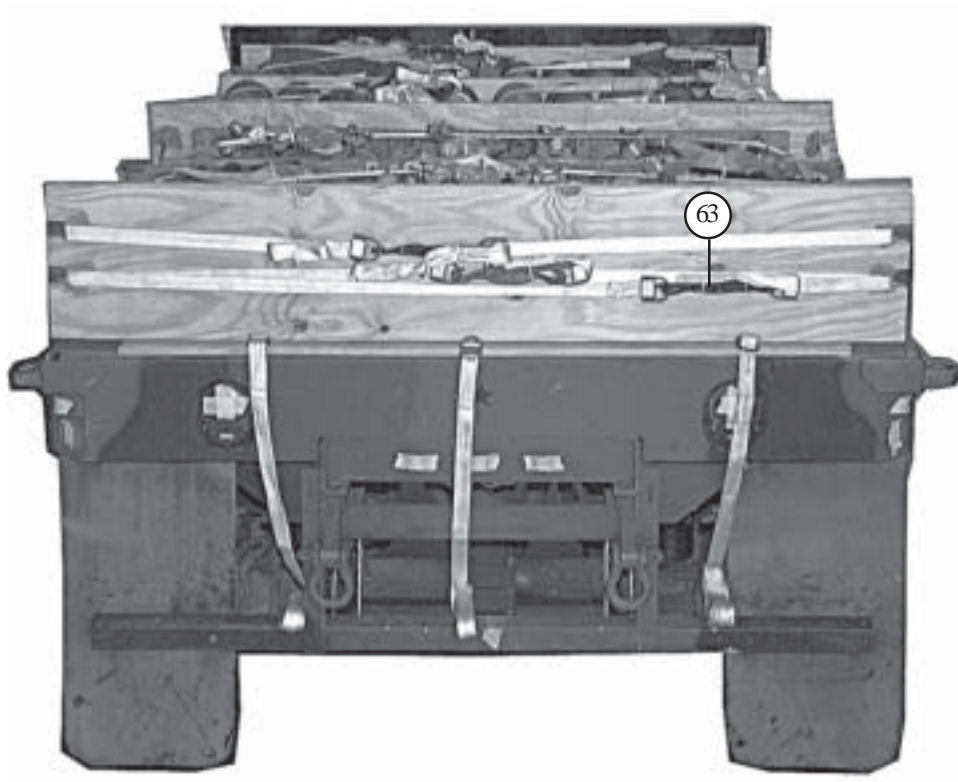
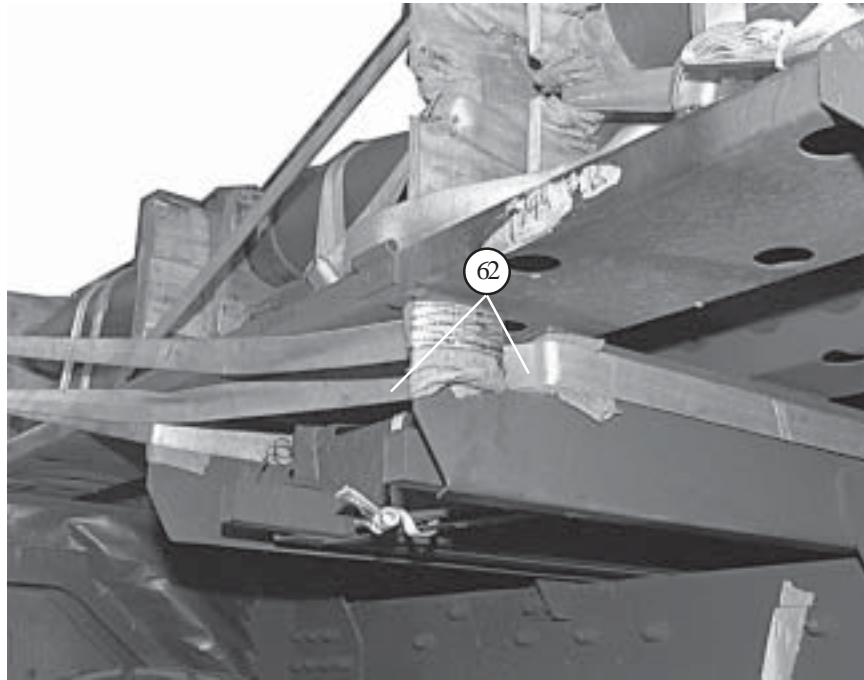

- ⑥2 Route a 30-foot lashing to the outside of the front ladder frame through the holes.
- ⑥3 Route the lashing through the lower cutouts of the rear endboards. Secure with loadbinder in the rear.

Figure 5-12. Trailer accompanying load stowed (Continued)

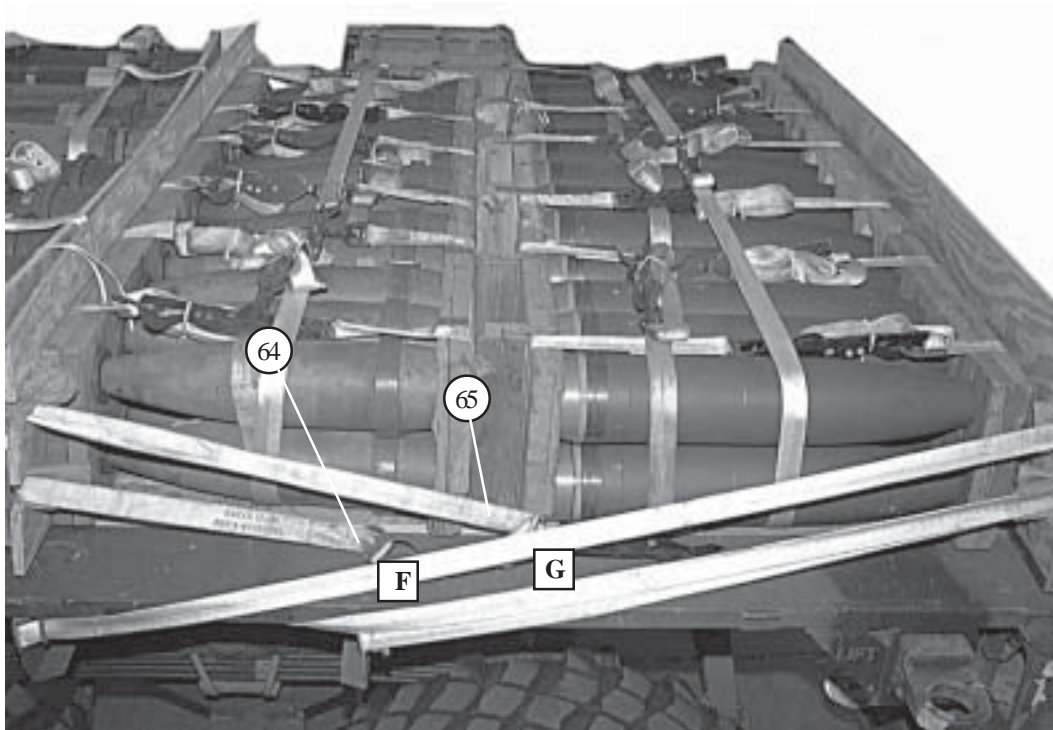

- ⑥4 Secure the lashings with a loadbinder and D-rings from step 51, Figure 5-12, F trailer bed tiedown ring to F1 trailer bed tiedown ring.
- ⑥5 Secure the lashings with a loadbinder and D-rings from step 52, Figure 5-12, G trailer bed tiedown ring to G1 trailer bed tiedown ring.

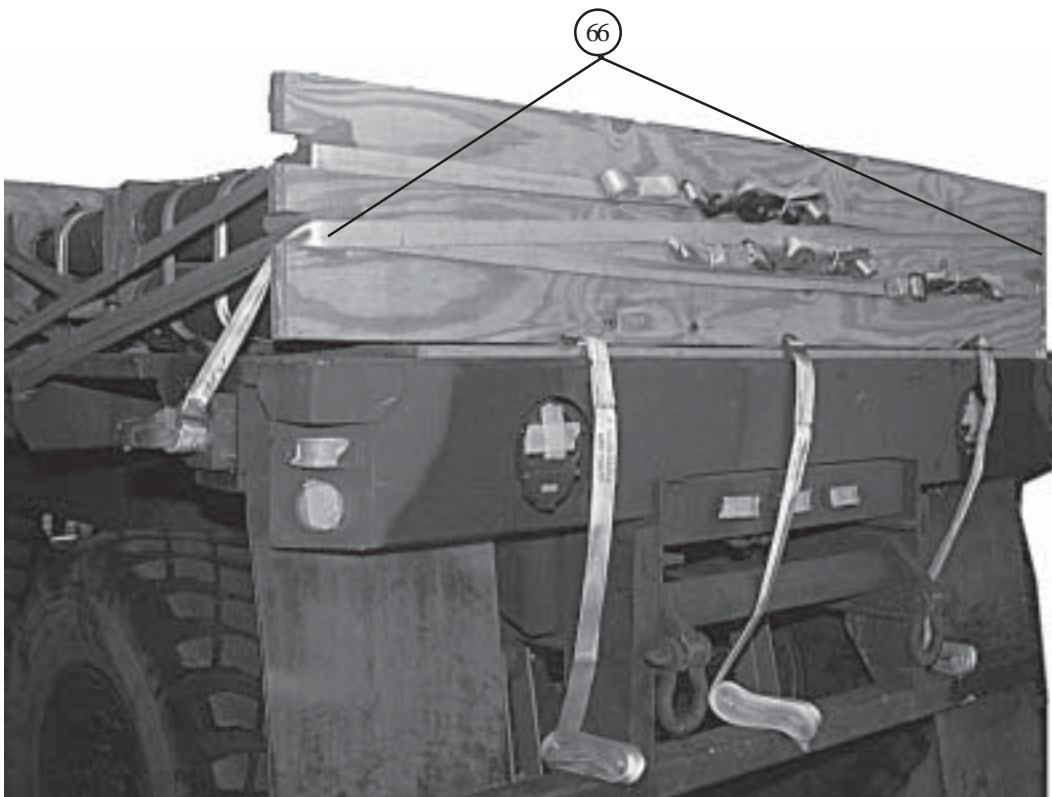

- ⑥⑥ Route a lashing through the trailer rear left sling guide and back through it's own D-ring, through the lower left cutout and through the right upper cutout of the rear endboards.

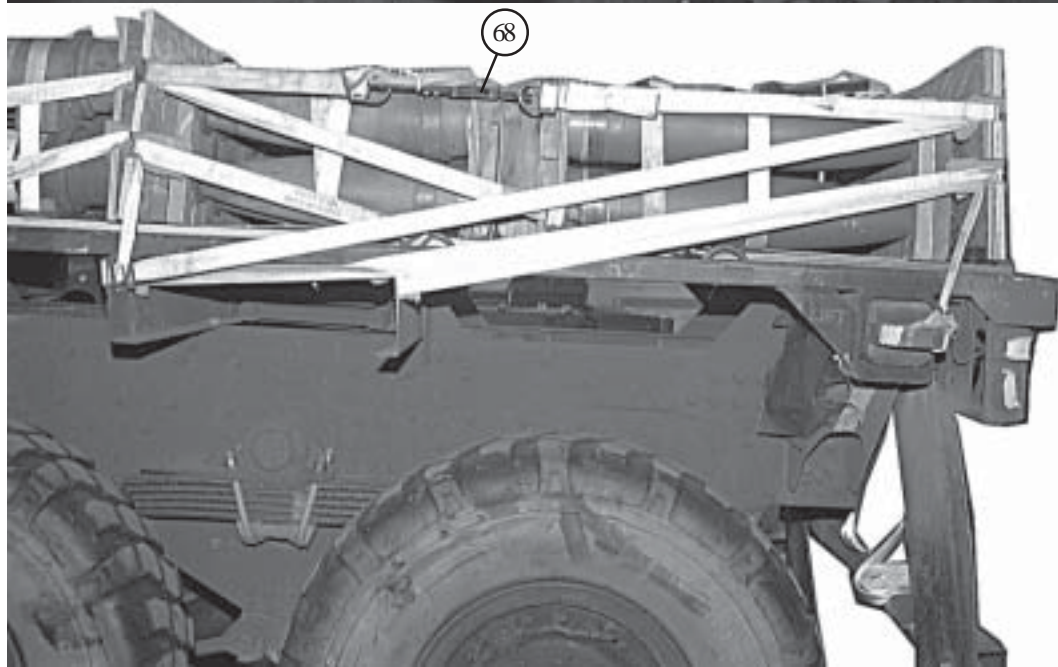
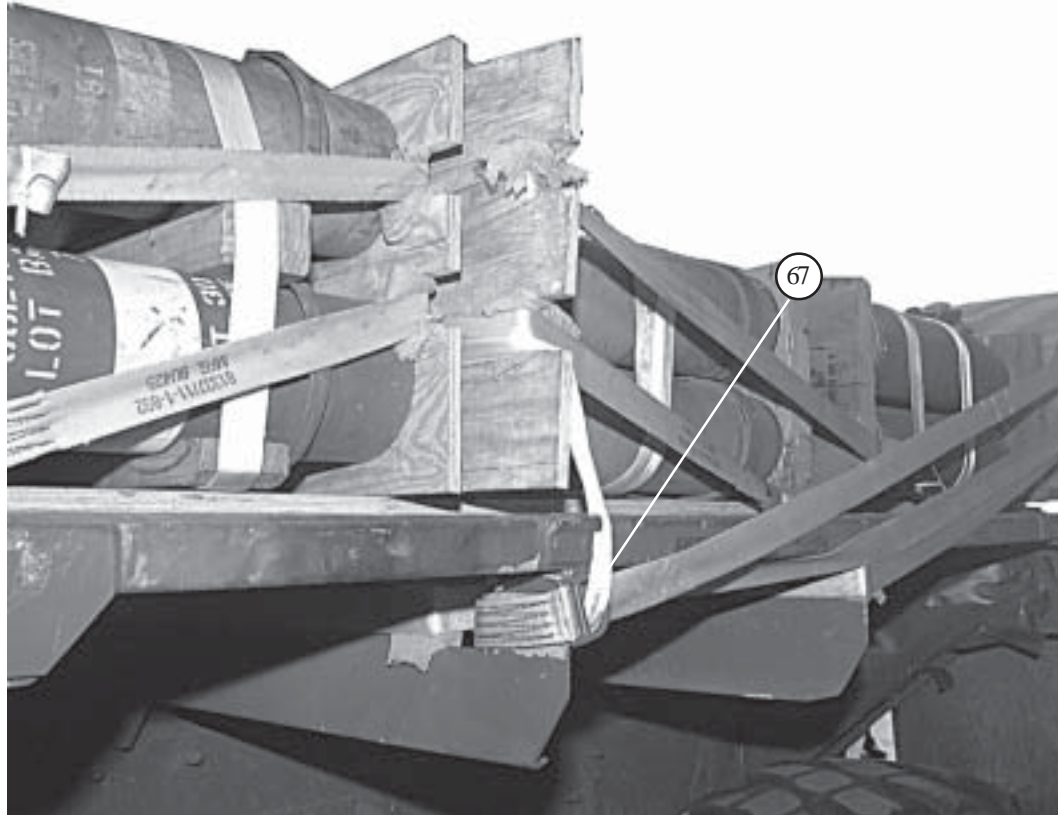

- 67 Route a 15-foot lashing through the hole in front of the ladder frame on the left side and back through it's own D-ring, through the lower left cutout and through the right upper cutout of the front endboard. Secure with loadbinder to the lashing from step 66 on the right side.
- 68 Repeat steps 66 and 67 on the opposite sides of the trailer.

Figure 5-12. Trailer accompanying load stowed (Continued)

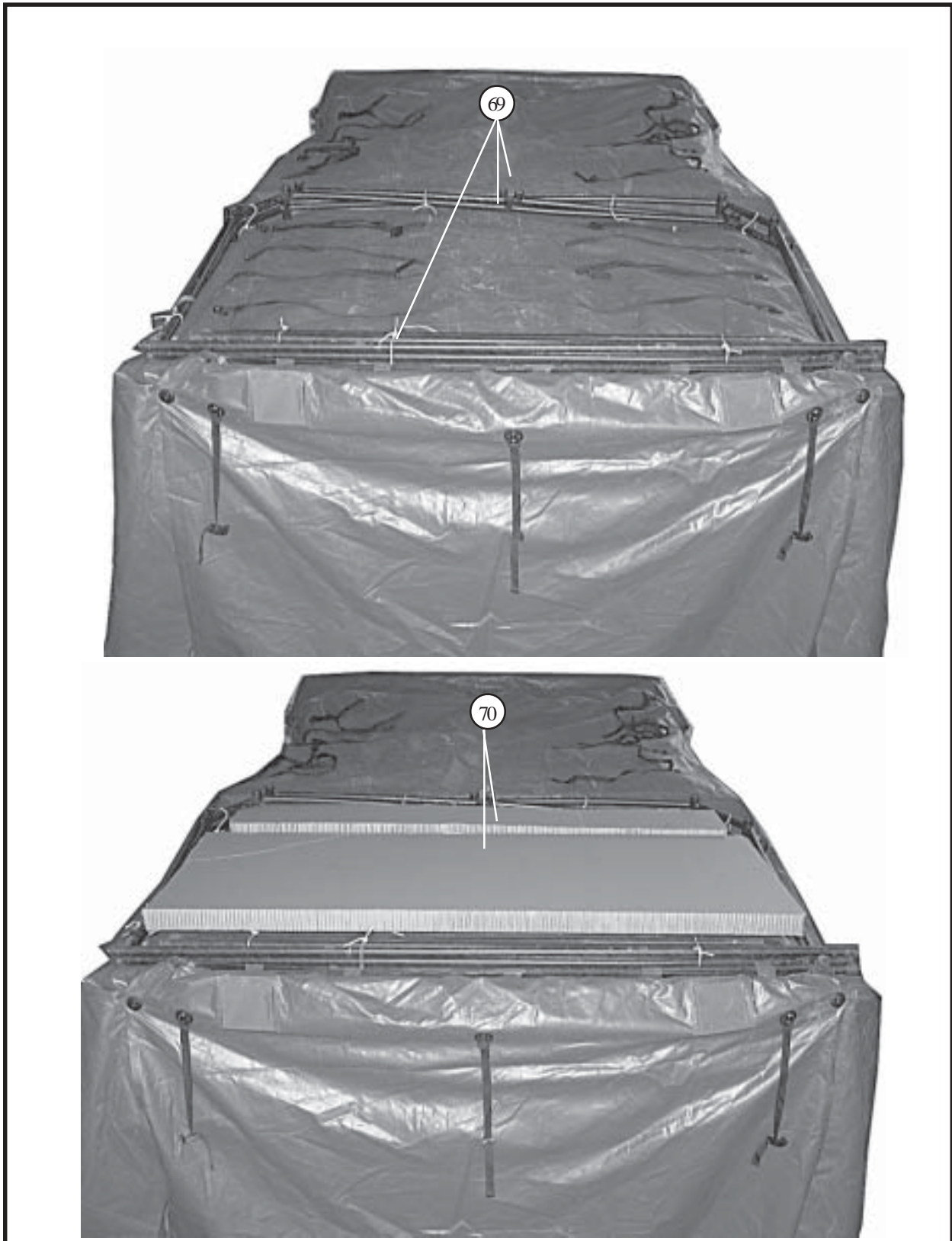

- ⑥9 Place the cargo cover over the trailer with the bows, spreaders and poles on top of the cargo cover. Secure with type III nylon cord on cell #3.
- ⑦0 Fill the empty space with honeycomb.

Figure 5-12. Trailer accompanying load stowed (Continued)

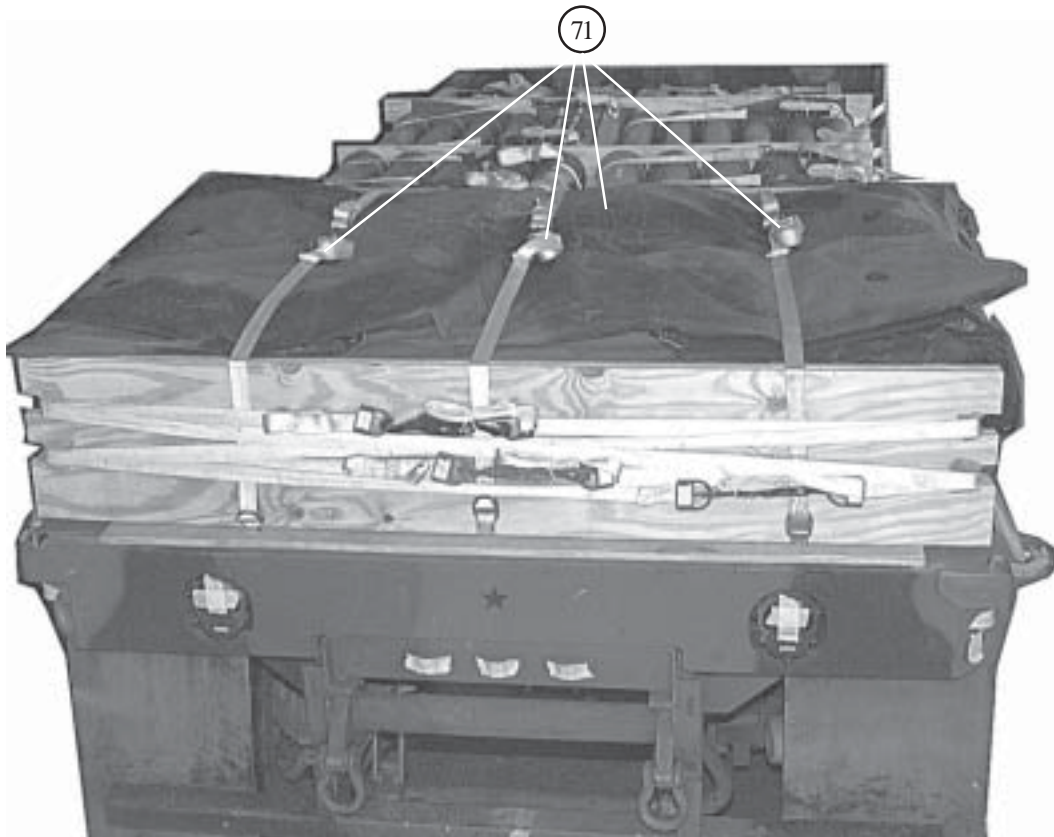

- 71 Fold the cargo cover over the bows, spreaders, poles and honeycomb on cell #3. Secure the three pre-positioned 30-foot lashings positioned in step 47 on top with loadbinders.

Figure 5-12. Trailer accompanying load stowed (Continued)

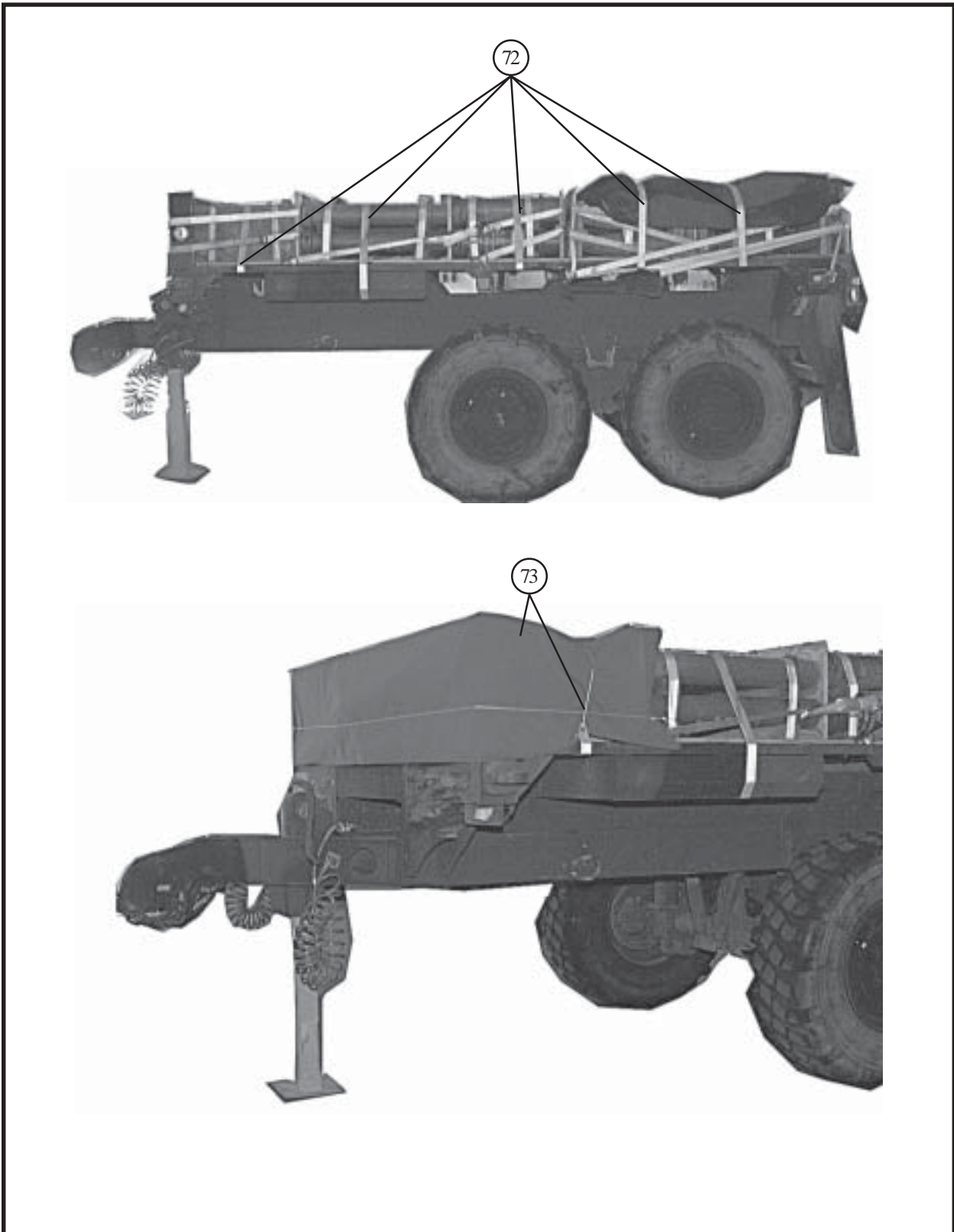

72 Route five 30-foot lashings under the trailer bed and over the racks of each cell. Secure each with a load-binder on top.

73 Cut and place a 60- by 133-inch piece of coated cloth over cell #1 and the trailer bed front. Secure with type III nylon cord.

Figure 5-12. Trailer accompanying load stowed (Continued)

5-8. Lifting and Positioning Trailer

Install lifting slings on the M1095 trailer and position the trailer as shown in *Figure 5-13* and described below.

a. Construct a lifting kit using an 11-foot (4-loop), type XXVI sling with a large clevis attached to each rear sling/lifting points. Attach a large clevis to an 11-foot (4-loop), type XXVI sling to each front sling/lifting points.

b. Position the load so that the rear bumper of the trailer is 64 inches from the front edge of the platform and centered.

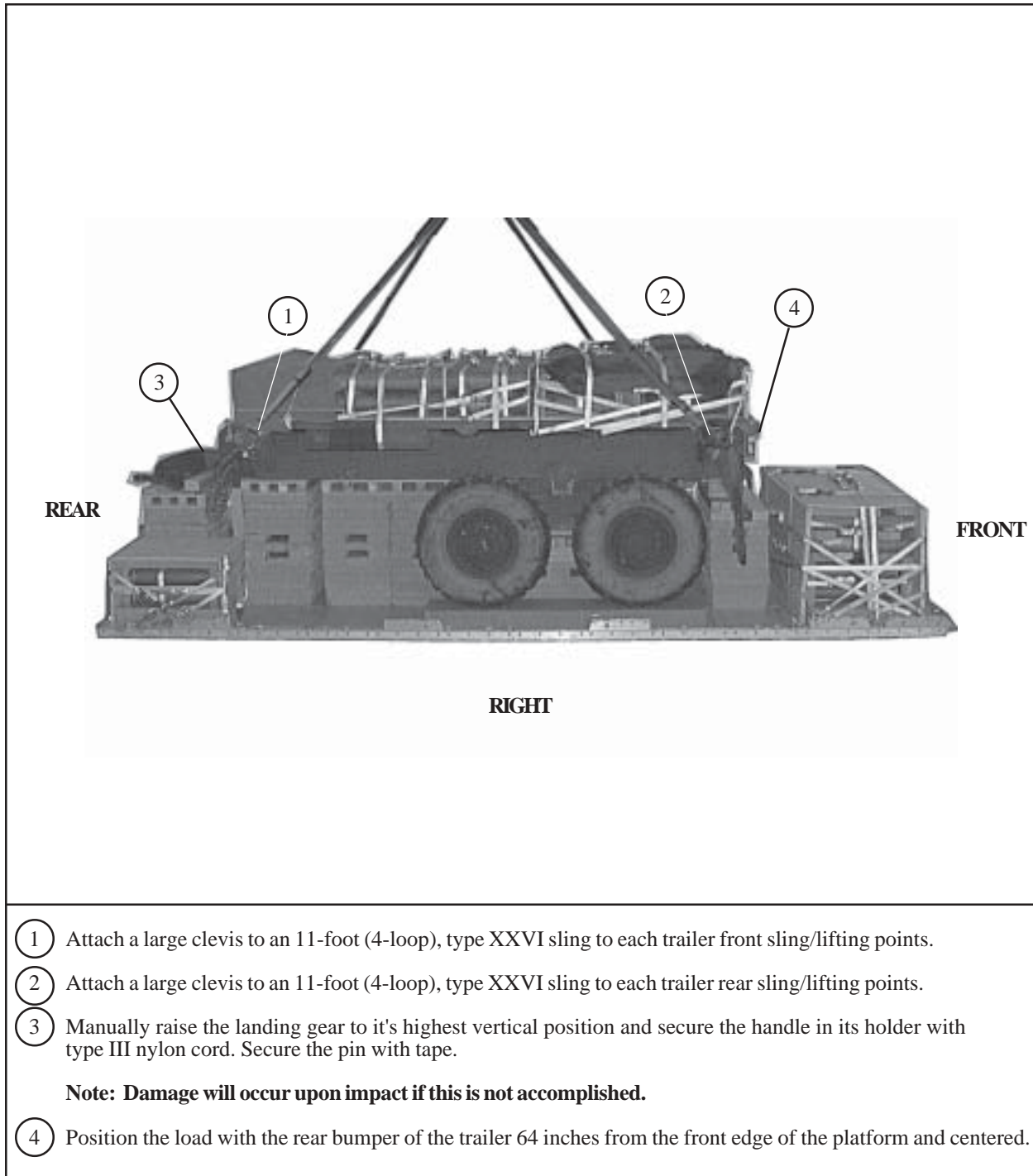

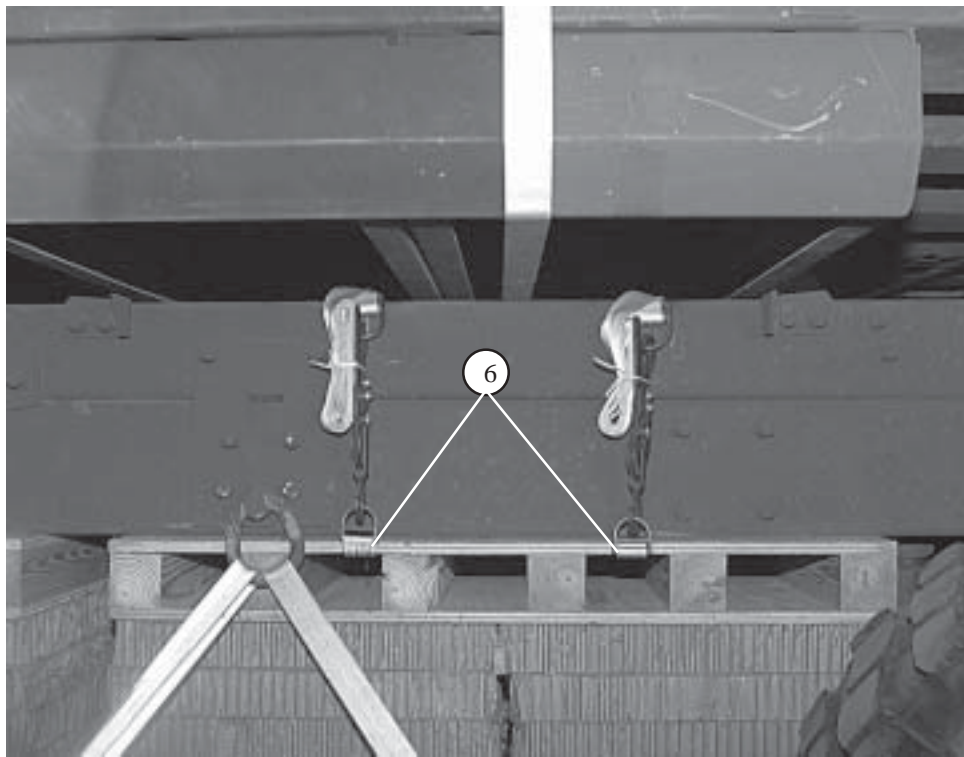
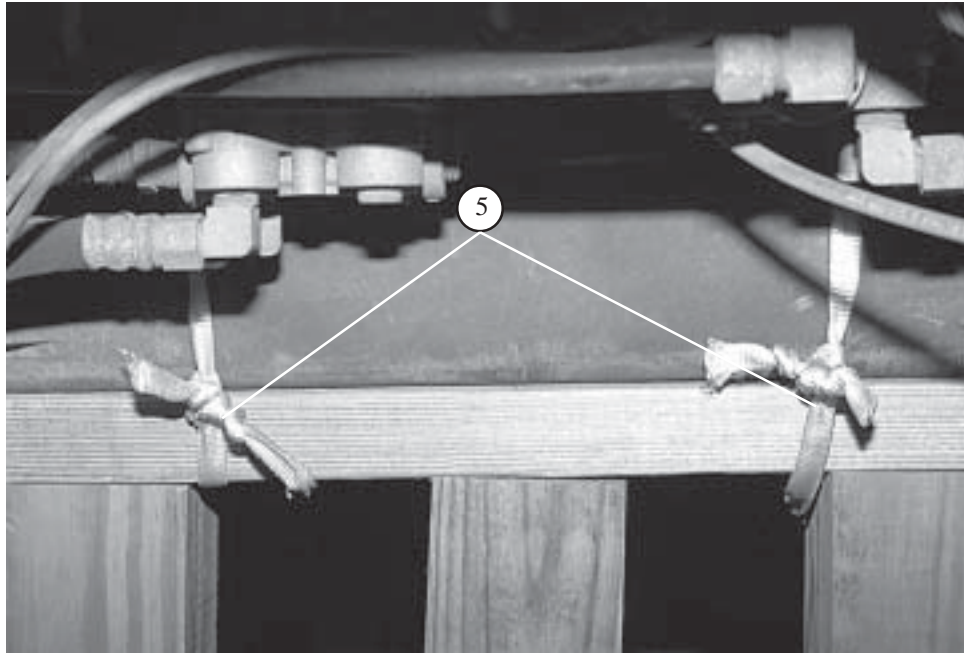

- 5 Place 1/2-inch tubular nylon webbing around the 4- by 4-inch lumber upright of stack #2 and the trailer frame and secure.
- 6 Route a lashing through the second hole of stack #3 and around the trailer frame. Secure with loadbinder on the side. Repeat for the fourth hole.

Figure 5-13. Load positioned (Continued)

5-9. Installing Lashings

Install lashings according to FM 4-20.102/NAVSEA SS400-AB-MMO-010/TO 13C7-1-5 and as shown in *Figure 5-14*.

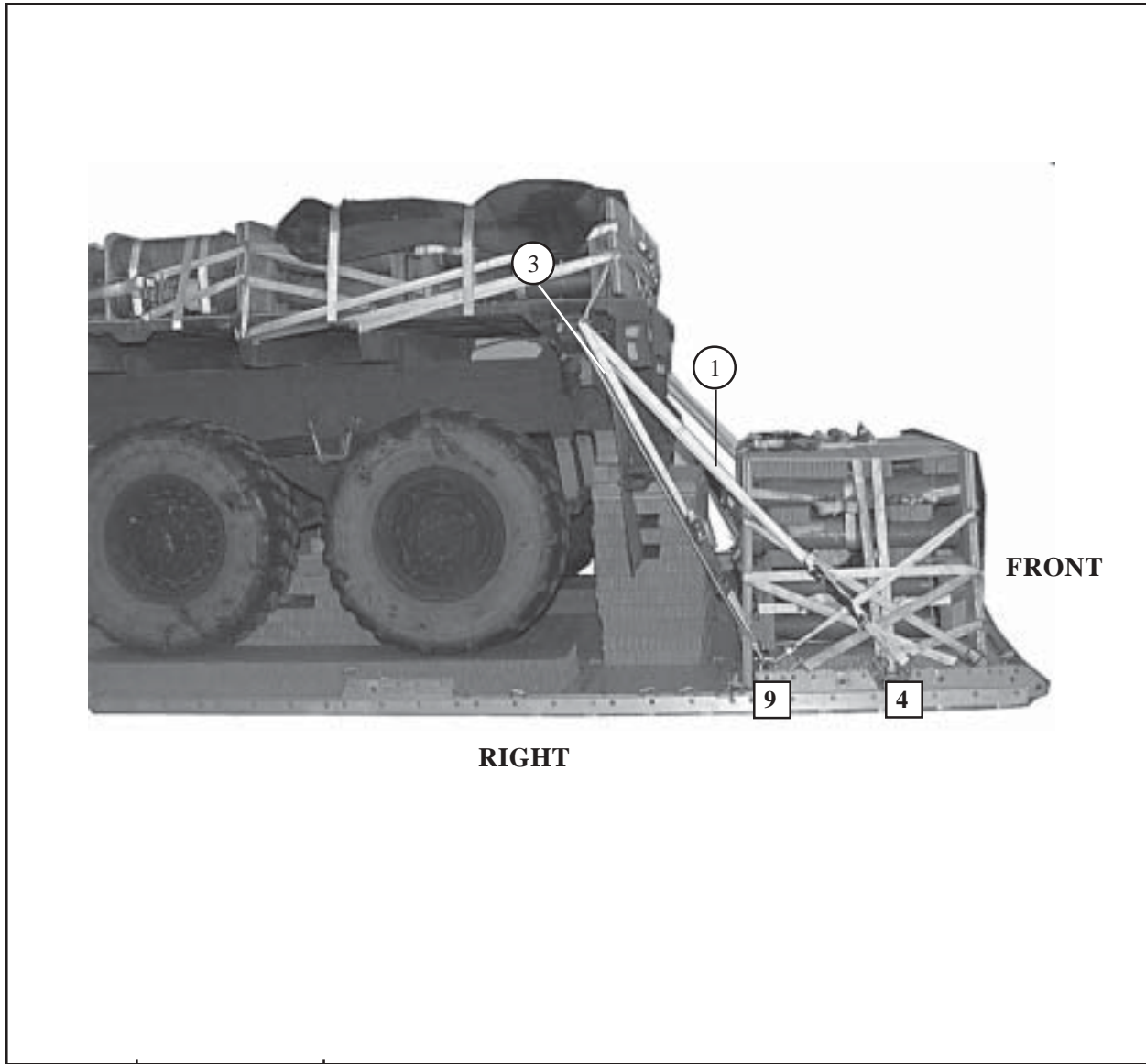

Lashing Number	Tiedown Clevis Number	Instructions
1	4	Route lashing: Through trailer's left rear sling guide.
2	4A	Through trailer's right rear sling guide.
3	9	Through trailer's left rear sling guide.
4	9A	Through trailer's right rear sling guide.

Figure 5-14. Trailer lashed to the platform

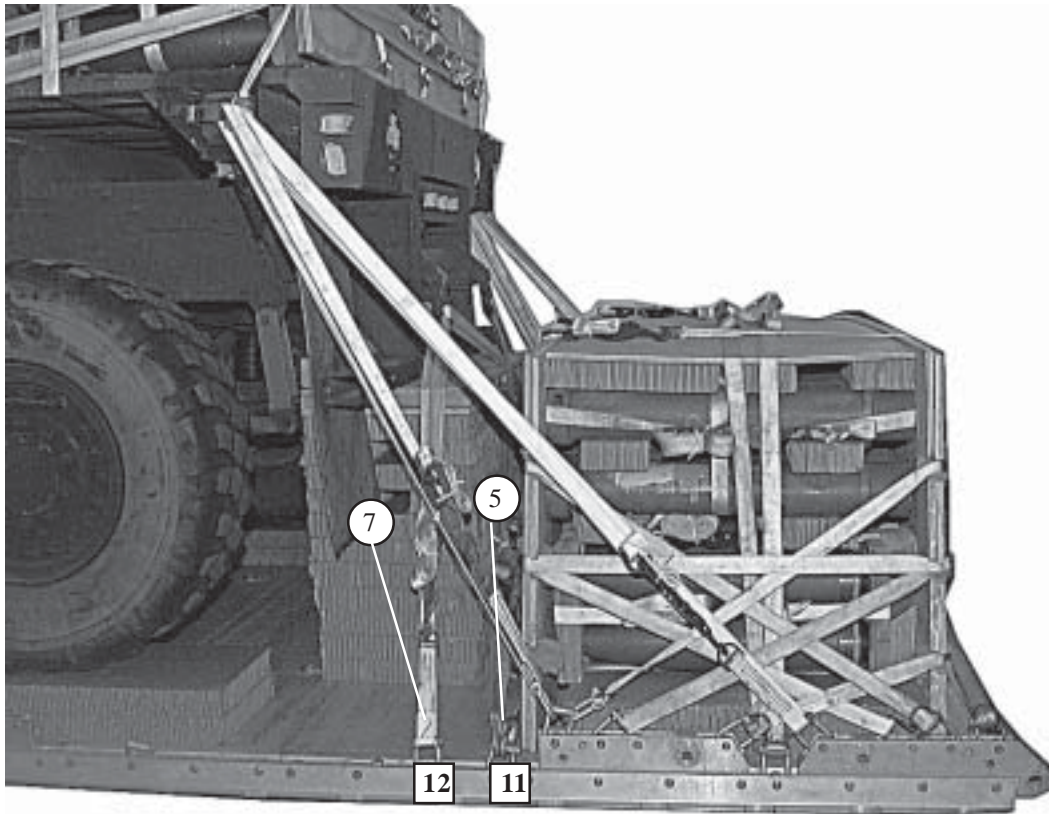

Lashing Number	Tiedown Clevis Number	Instructions
5	11	Route lashing: Through trailer's right rear tiedown shackle.
6	11A	Through trailer's left rear tiedown shackle.
7	12	Through trailer's left rear tiedown shackle.
8	12A	Through trailer's right rear tiedown shackle.

Figure 5-14. Trailer lashed to the platform (Continued)

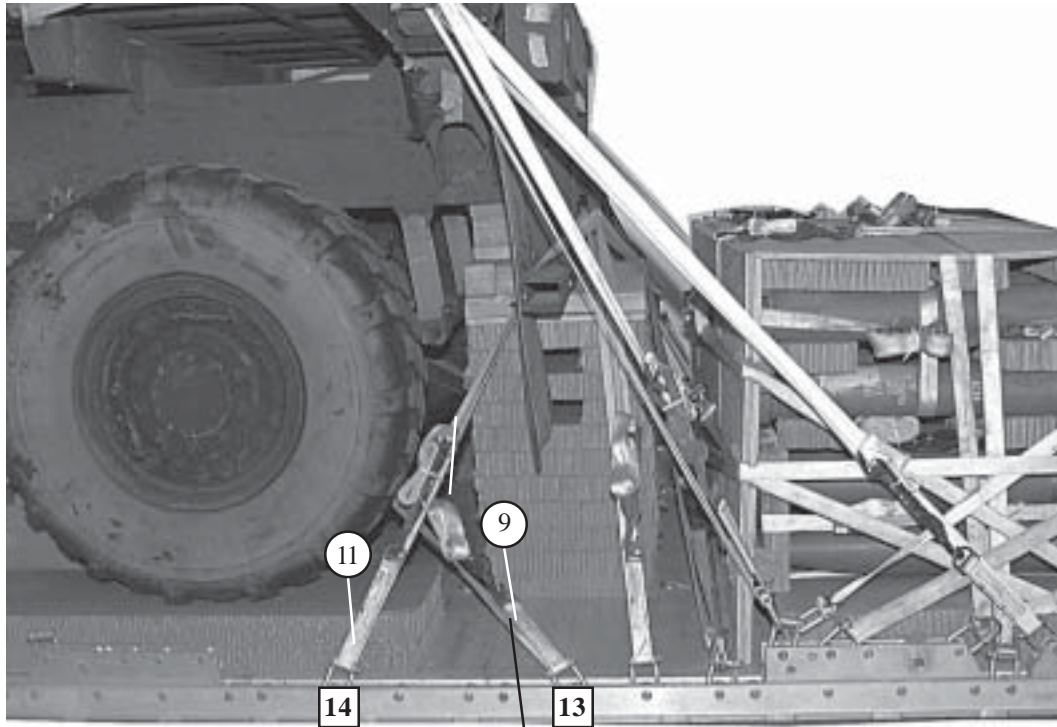

RIGHT



Lashing Number	Tiedown Clevis Number	Instructions
9	13	<p>Route lashing:</p> <p>Around the trailer's left rear axle, inside the torsion bar. Note: Use ample cellulose wadding to prevent lashing damage.</p>
10	13A	<p>Around the trailer's right rear axle, inside the torsion bar. Note: Use ample cellulose wadding to prevent lashing damage.</p>
11	14	<p>Over the top of the bumper and through the trailer's left rear, tiedown shackle.</p>
12	14A	<p>Over the top of the bumper and through the trailer's right rear, tiedown shackle.</p>

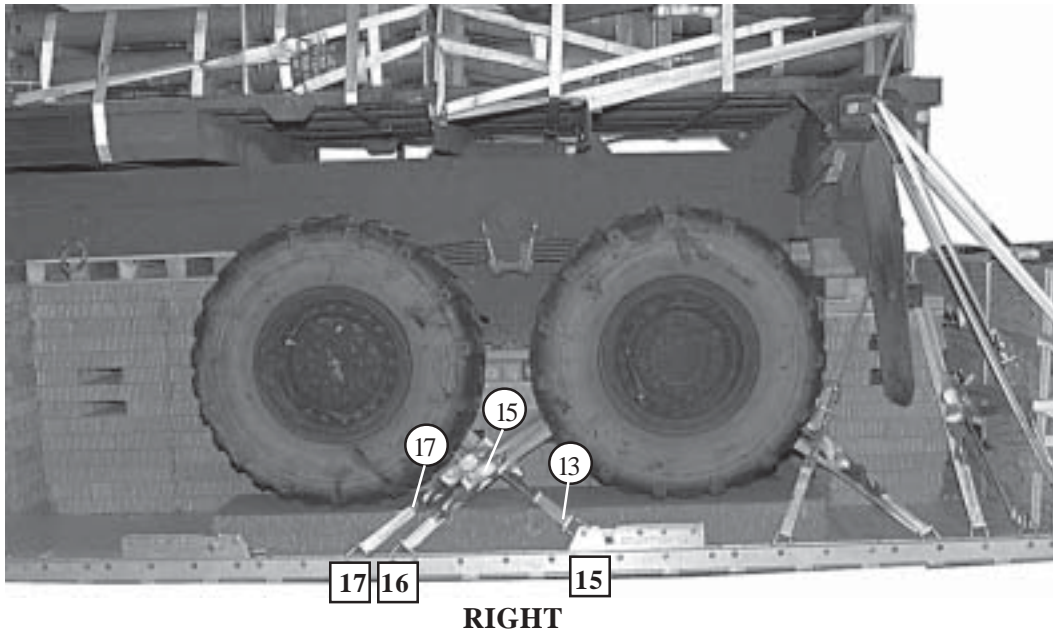

Lashing Number	Tiedown Clevis Number	Instructions
13	15	Route lashing: Around the trailer's front left axle, inside the torsion bar.
14	15A	Around the trailer's front right axle, inside the torsion bar.
15	16	Around the trailer's rear left axle, inside the torsion bar.
16	16A	Around the trailer's rear right axle, inside the torsion bar.
17	17	Around the trailer's rear left axle, inside the torsion bar.
18	17A	Around the trailer's rear right axle, inside the torsion bar.

Figure 5-14. Trailer lashed to the platform (Continued)

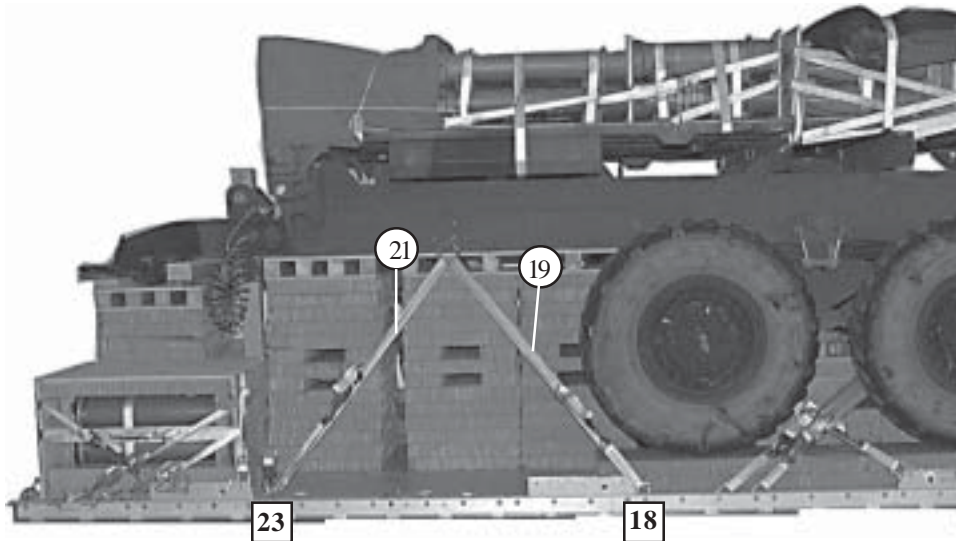

Lashing Number	Tiedown Clevis Number	Instructions
19	18	Route lashing: Through the trailer's front left side tiedown shackle.
20	18A	Through the trailer's front right side tiedown shackle.
21	23	Through the trailer's front left side tiedown shackle.
22	23A	Through the trailer's front right side tiedown shackle.

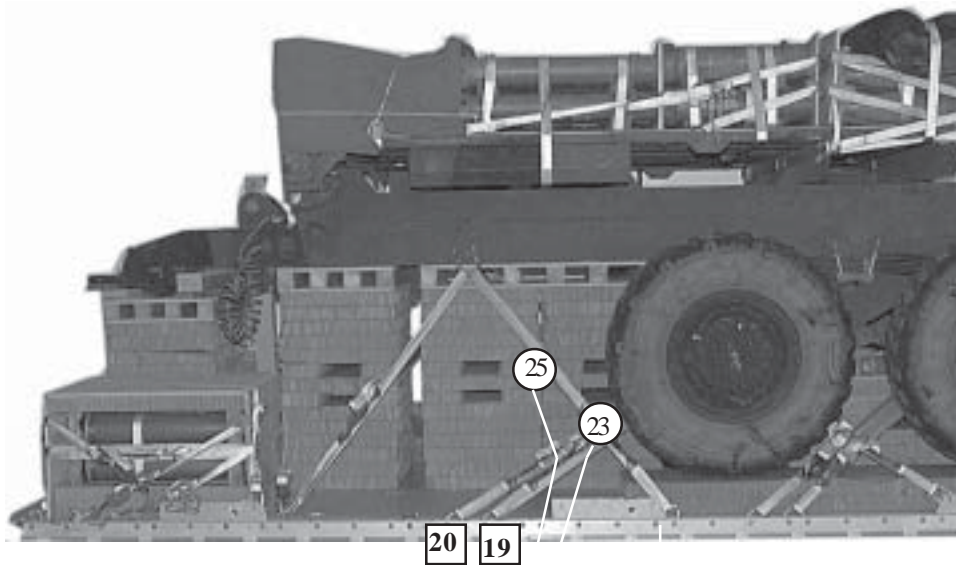

Lashing Number	Tiedown Clevis Number	Instructions
23	19	Route lashing: Around the trailer's front left axle, inside the torsion bar.
24	19A	Around the trailer's front right axle, inside the torsion bar.
25	20	Around the trailer's front left axle, inside the torsion bar.
26	20A	Around the trailer's front right axle, inside the torsion bar.

Figure 5-14. Trailer lashed to the platform (Continued)

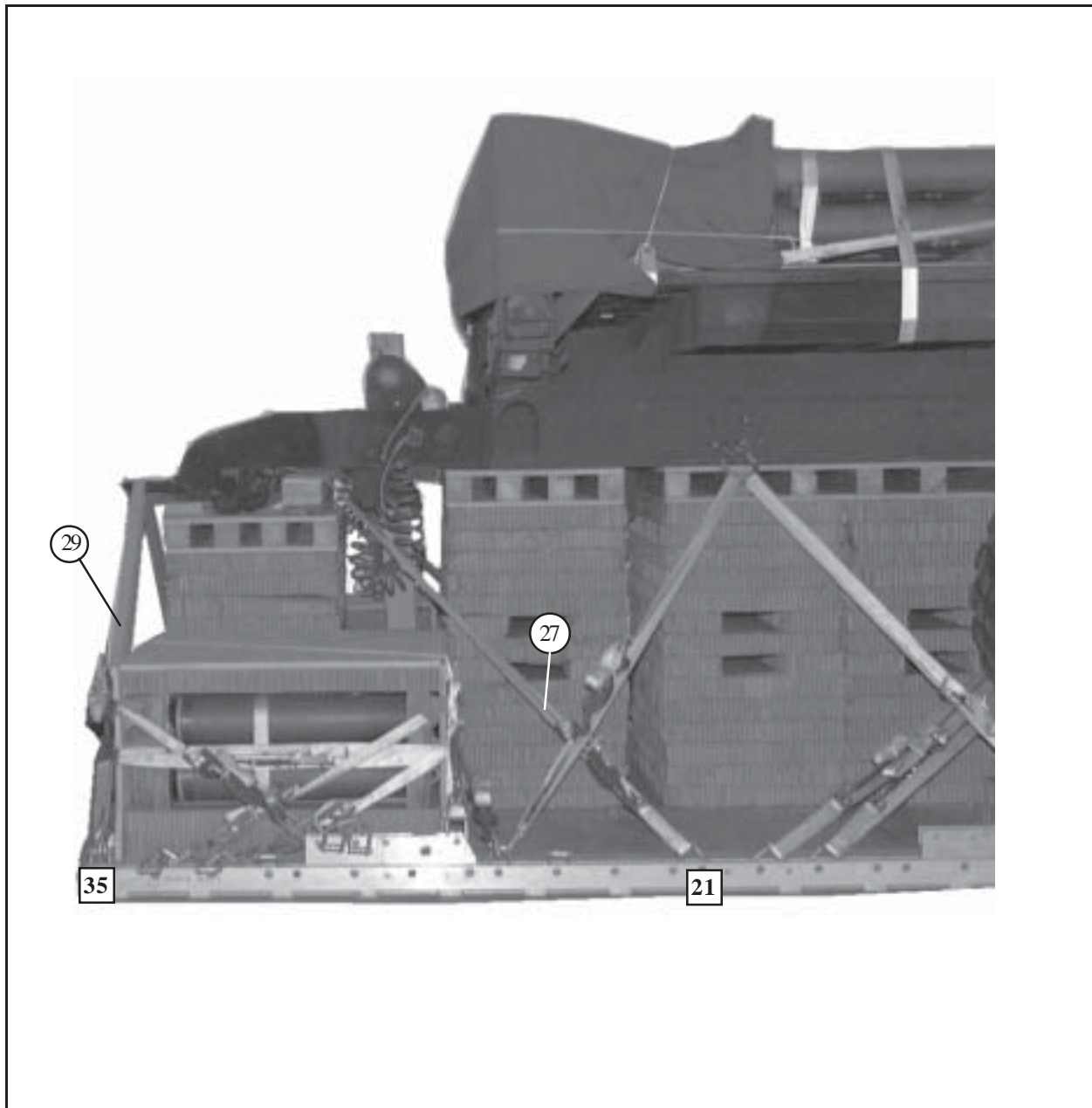

Lashing Number	Tiedown Clevis Number	Instructions
27	21	Route lashing: Through the trailer's left side safety chain bracket.
28	21A	Through the trailer's right side safety chain bracket.
29	35	Through the lunette.
30	35A	Through the lunette.

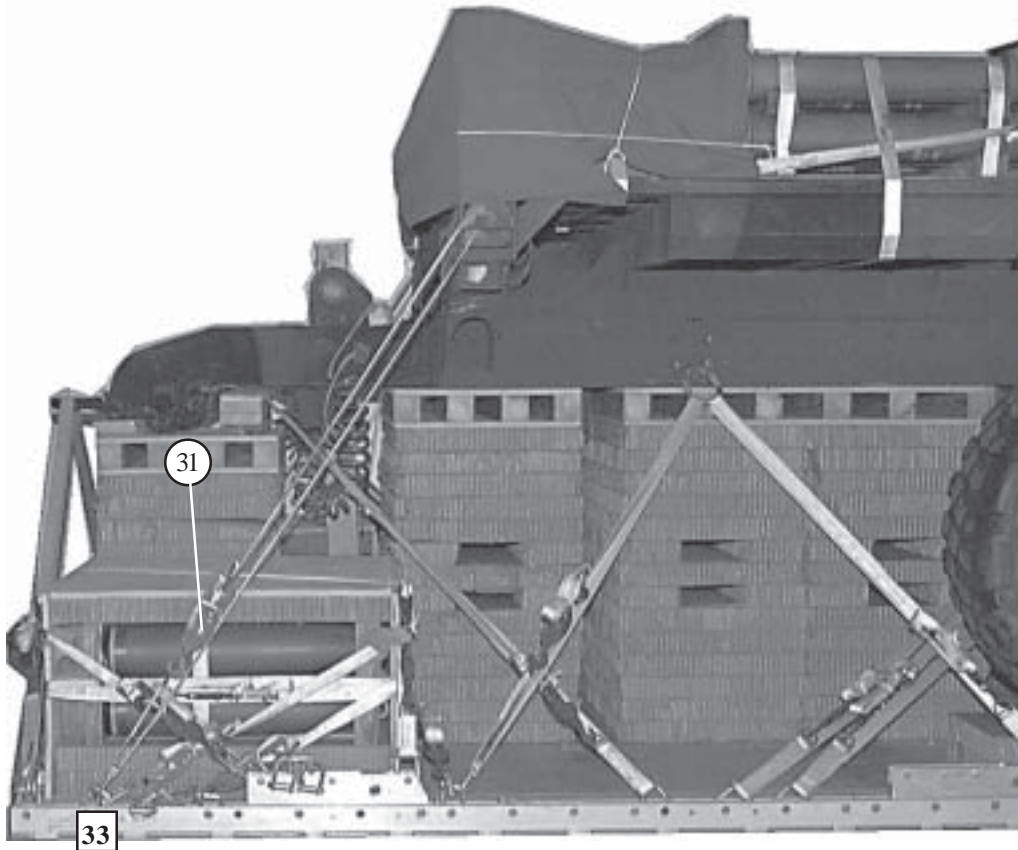

Lashing Number	Tiedown Clevis Number	Instructions
31	33	Route lashing: Through the trailer's front left sling guide.
32	33A	Through the trailer's front right sling guide.

Figure 5-14. Trailer lashed to the platform (Continued)

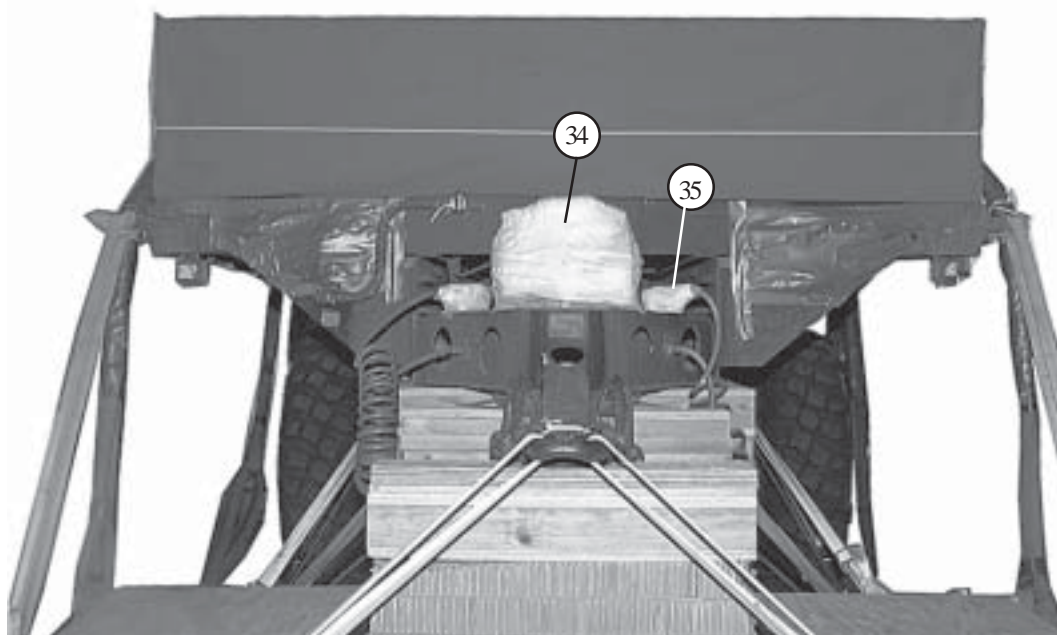

- ③③ Secure the safety chains with type III nylon cord (Not Shown).
- ③④ Pad with cellulose wadding and tape the crank gearbox.
- ③⑤ Pad with cellulose wadding and tape the trailer left side air supply hose springs and connector.

5-10. Building Sling Spreader and Installing Suspension Slings

Build sling spreader and install the suspension slings according to FM 4-20.102/NAVSEA SS400-AB-MMO-010/TO 13C7-1-5 and as shown in *Figure 5-15*.

- Notes:**
1. This drawing is not drawn to scale.
 2. Use eightpenny nails to nail the plywood to the lumber.
 3. Construct sling spreader using one piece of 24-by 96-by 3/4-inch plywood, two pieces of 4- by 4- by 106-inch lumber, two pieces of 4- by 4- by 17-inch lumber, and three pieces of 2- by 4- by 89-inch lumber.

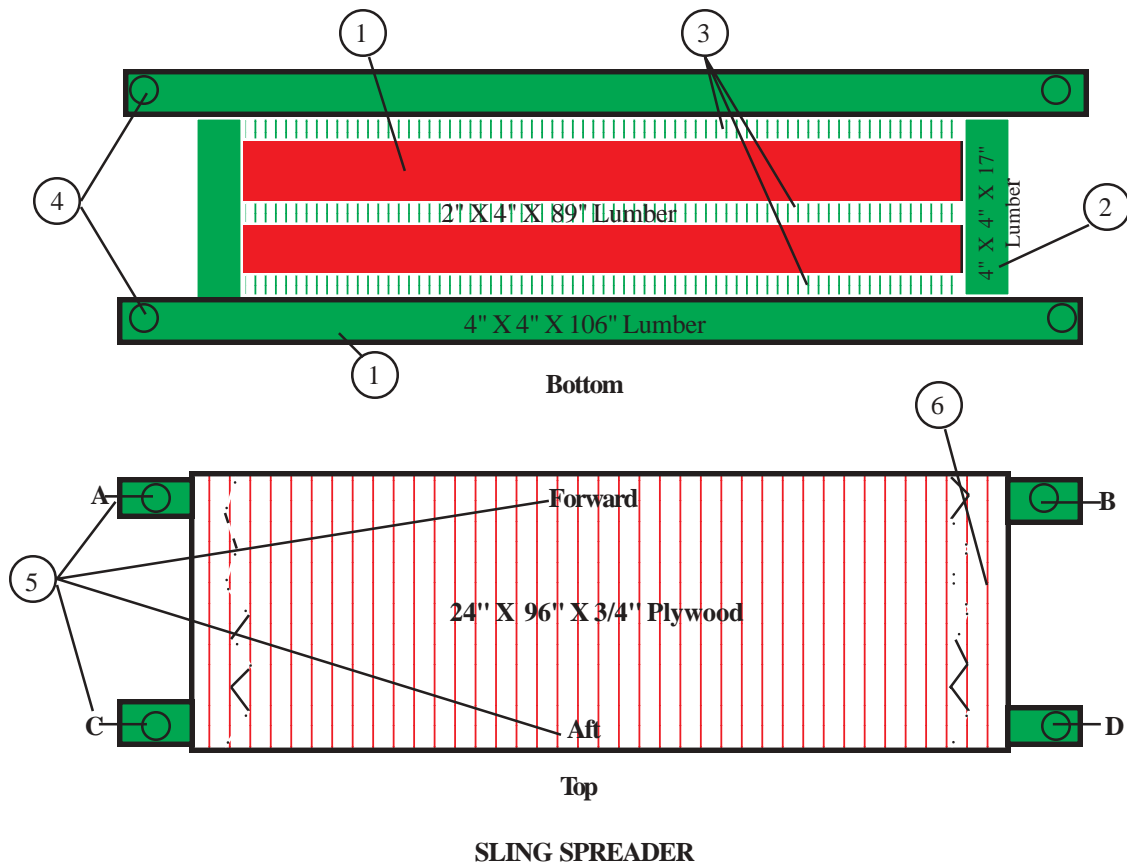

1. Nail a 4- by 4- by 106-inch piece of lumber flush with both 96 inch sides of a 24- by 96- by 3/4-inch piece of plywood allowing 5-inches on each end of the 4- by 4- by 106-inch pieces of lumber.
2. Nail a 4- by 4- by 17-inch piece of lumber flush with both 24 inch sides of the 24- by 96- by 3/4-inch piece of plywood.
3. Nail a 2- by 4- by 89-inch piece of lumber flush and inside next to both 96 inch sides of the 4- by 4- by 106-inch pieces of lumber. Nail the other 2- by 4- by 89-inch piece of lumber centered on the 24- by 96- by 3/4-inch piece of plywood.
4. Drill a 2-inch hole centered 3 inches from the ends of the 4- by 4- by 106-inch pieces of lumber.
5. Mark forward, aft and hole numbers for proper rigging.
6. Pad with felt and tape where slings come in contact with sling spreader.

Figure 5-15. Suspension slings installed

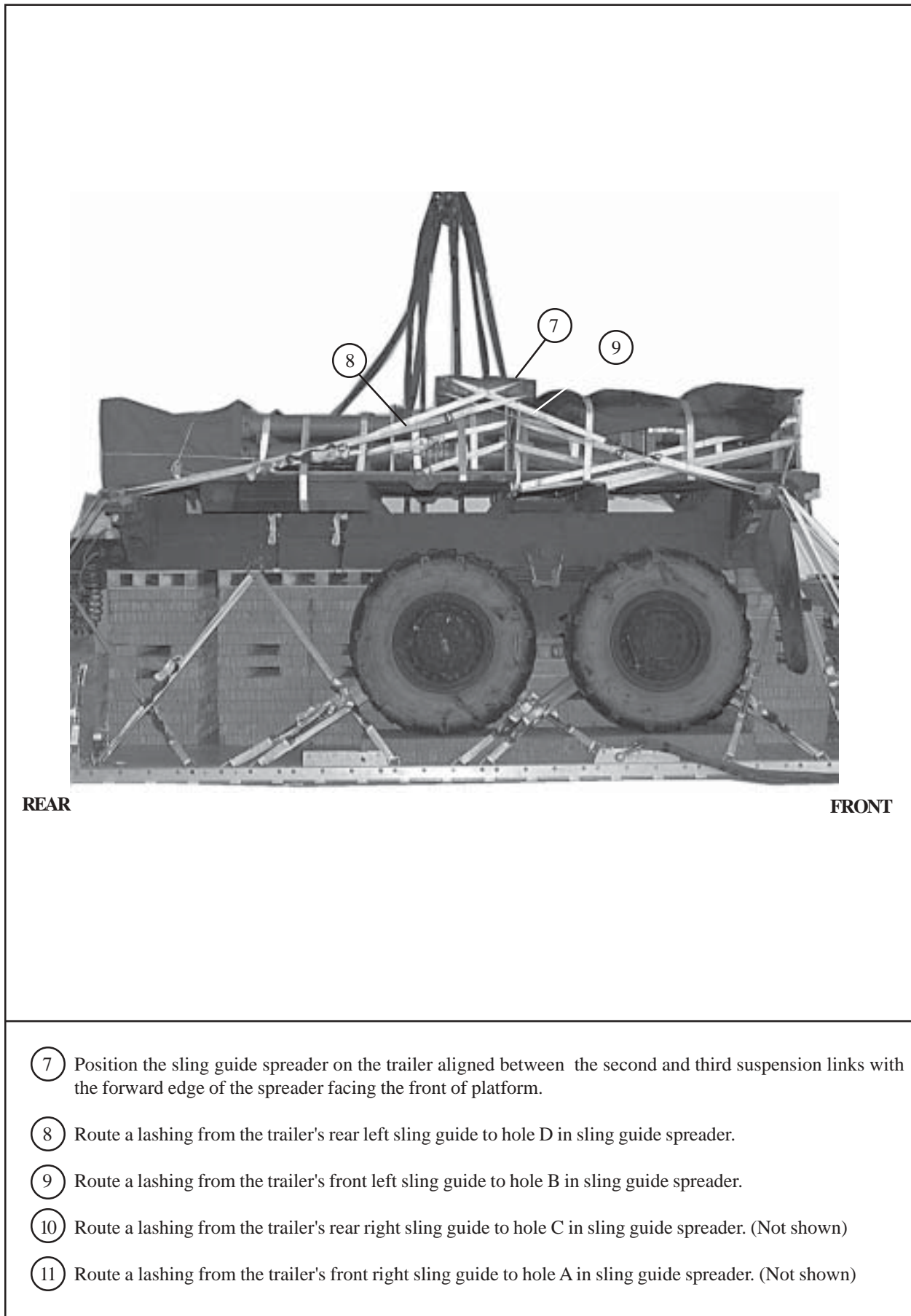
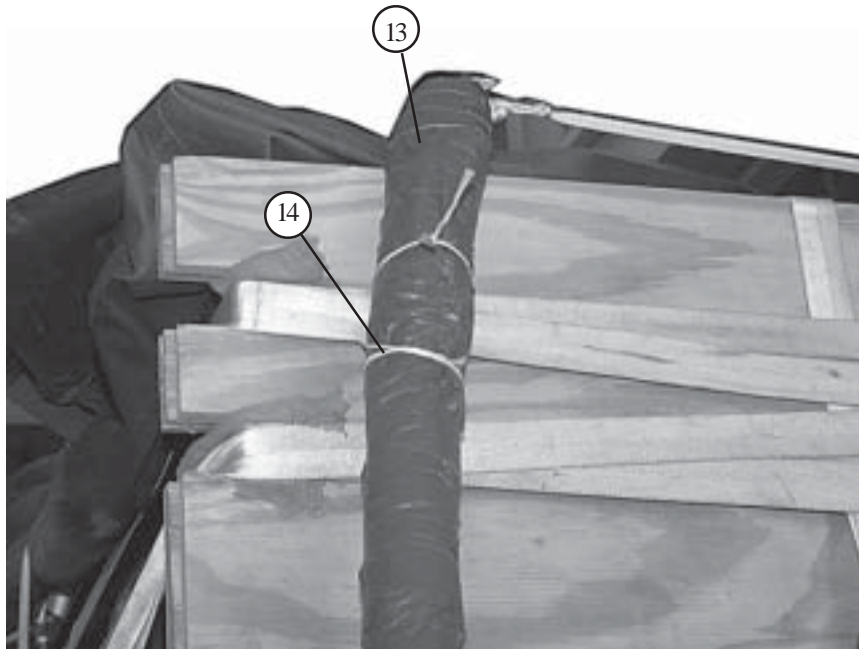
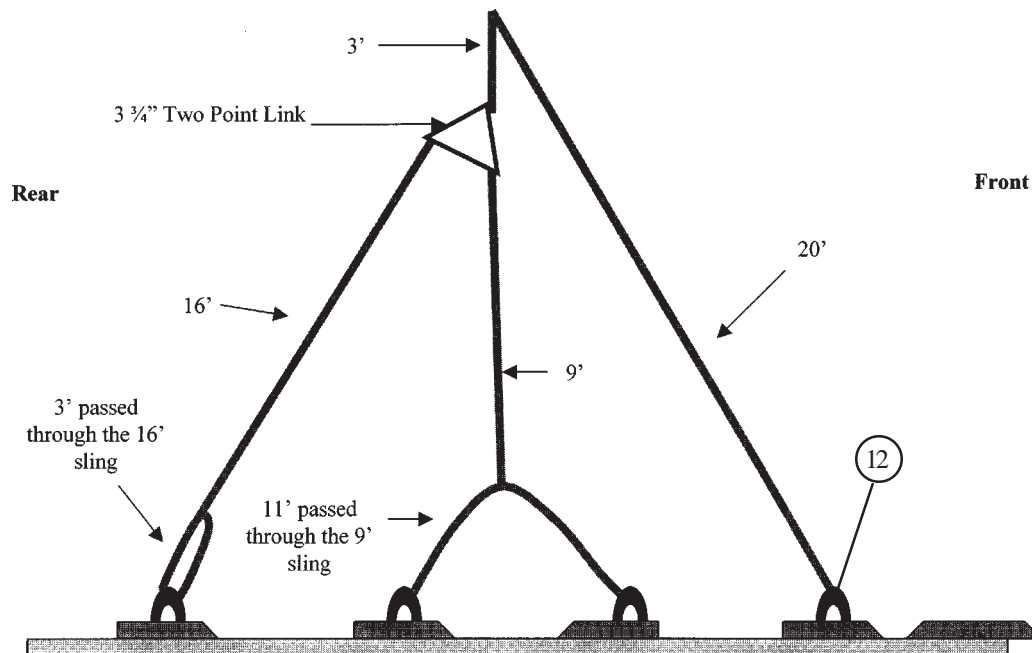

Figure 5-15. Suspension slings installed (Continued)

Note: This drawing is not drawn to scale.



- ⑫ Attach a large clevis to one end of a 20-foot (4-loop), type XXVI nylon sling.
- ⑬ Wrap the sling with felt and tape from 12 to 112 inches from the clevis.
- ⑭ Attach the clevis to the first suspension bracket. Secure the sling to a lashing at the rear of cell #3 with type I, 1/4-inch cotton webbing.

Figure 5-15. Suspension slings installed (Continued)

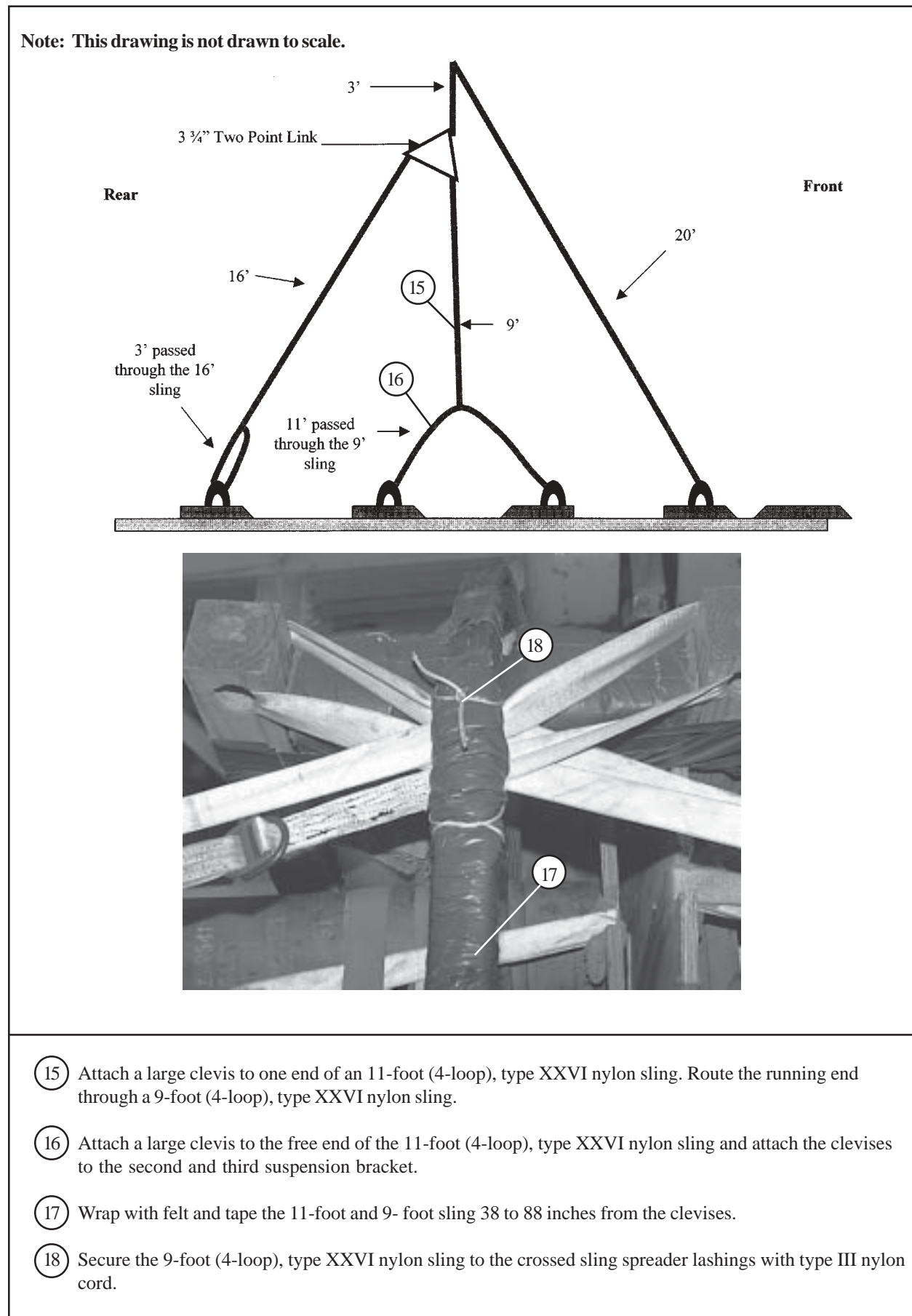

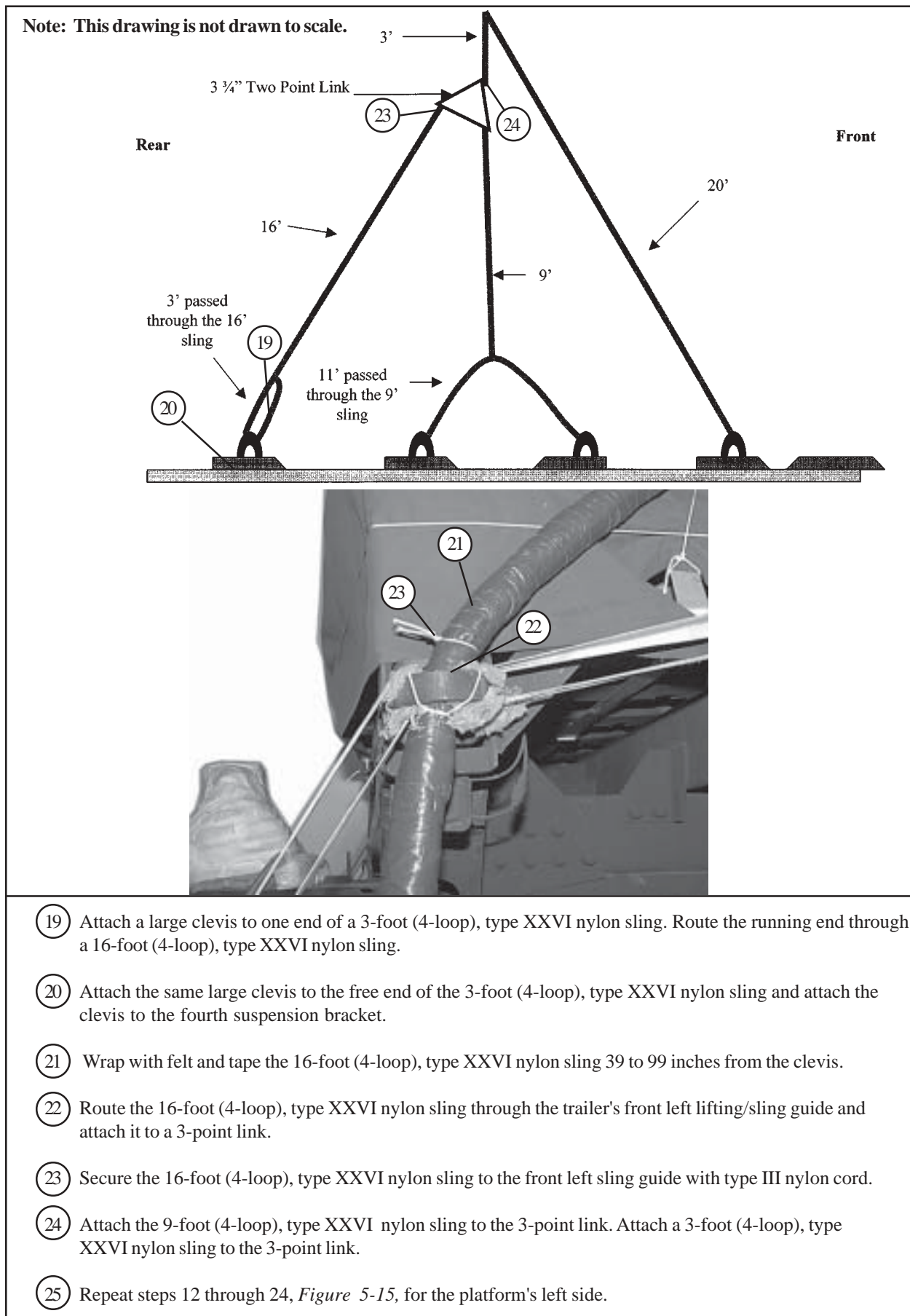

Figure 5-15. Suspension slings installed (Continued)

5-11. Safety Tying Suspension Slings

Safety tie the slings as described in *Figure 5-16*.

NOTICE OF EXCEPTION

The positioning of the safety tie is different from that in *FM 4-20.102/NAVSEA SS400-AB-MMO-010/TO 13C7-1-5*. An exception to *FM 4-20.102/NAVSEA SS400-AB-MMO-010/TO 13C7-1-5* is granted. The procedures in Appendix A and this paragraph must be followed.

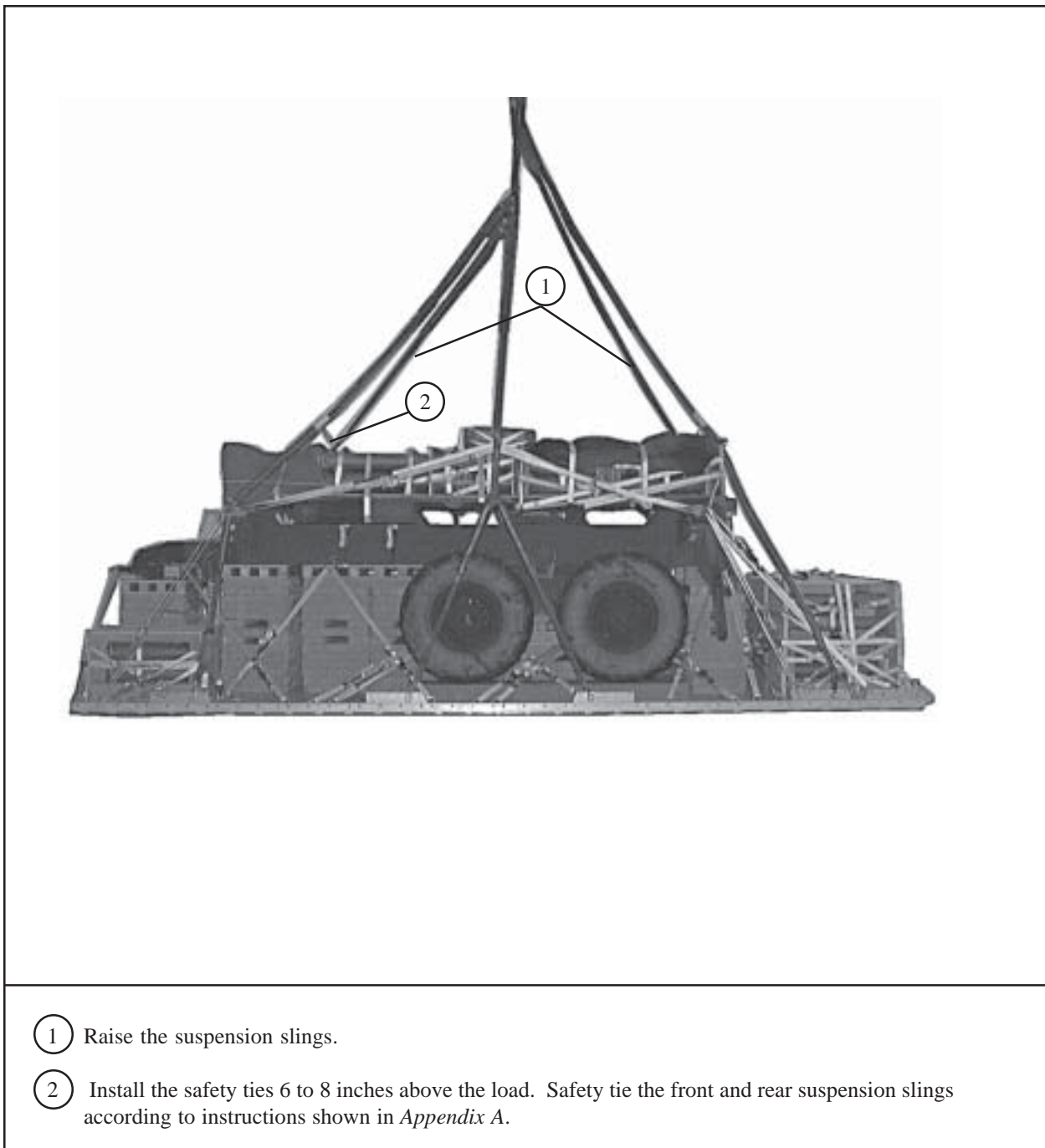

- ① Raise the suspension slings.
- ② Install the safety ties 6 to 8 inches above the load. Safety tie the front and rear suspension slings according to instructions shown in *Appendix A*.

5-12. Building and Positioning the Parachute Stowage Platform

Build and position the parachute stowage platform as shown in *Figure 5-17*.

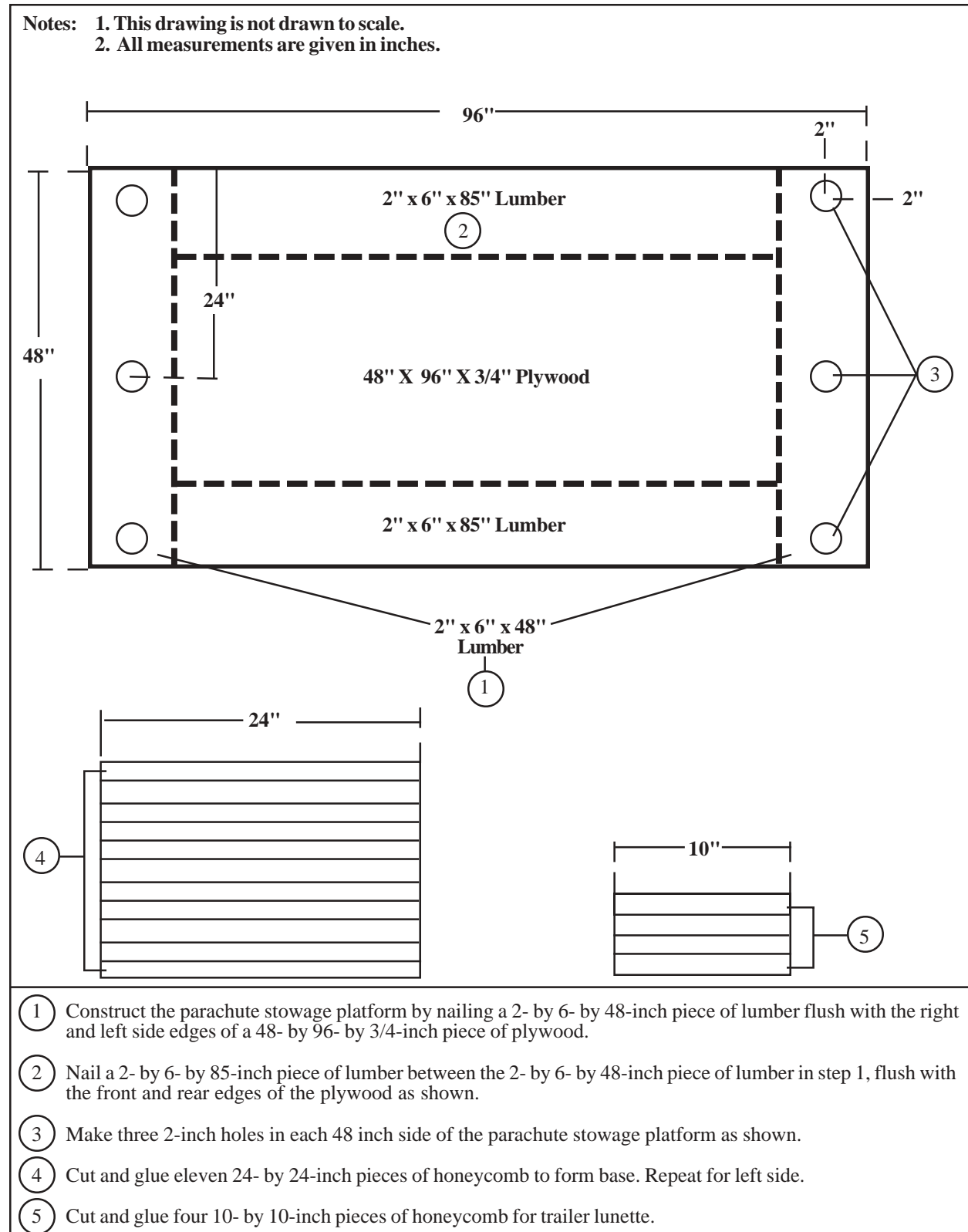
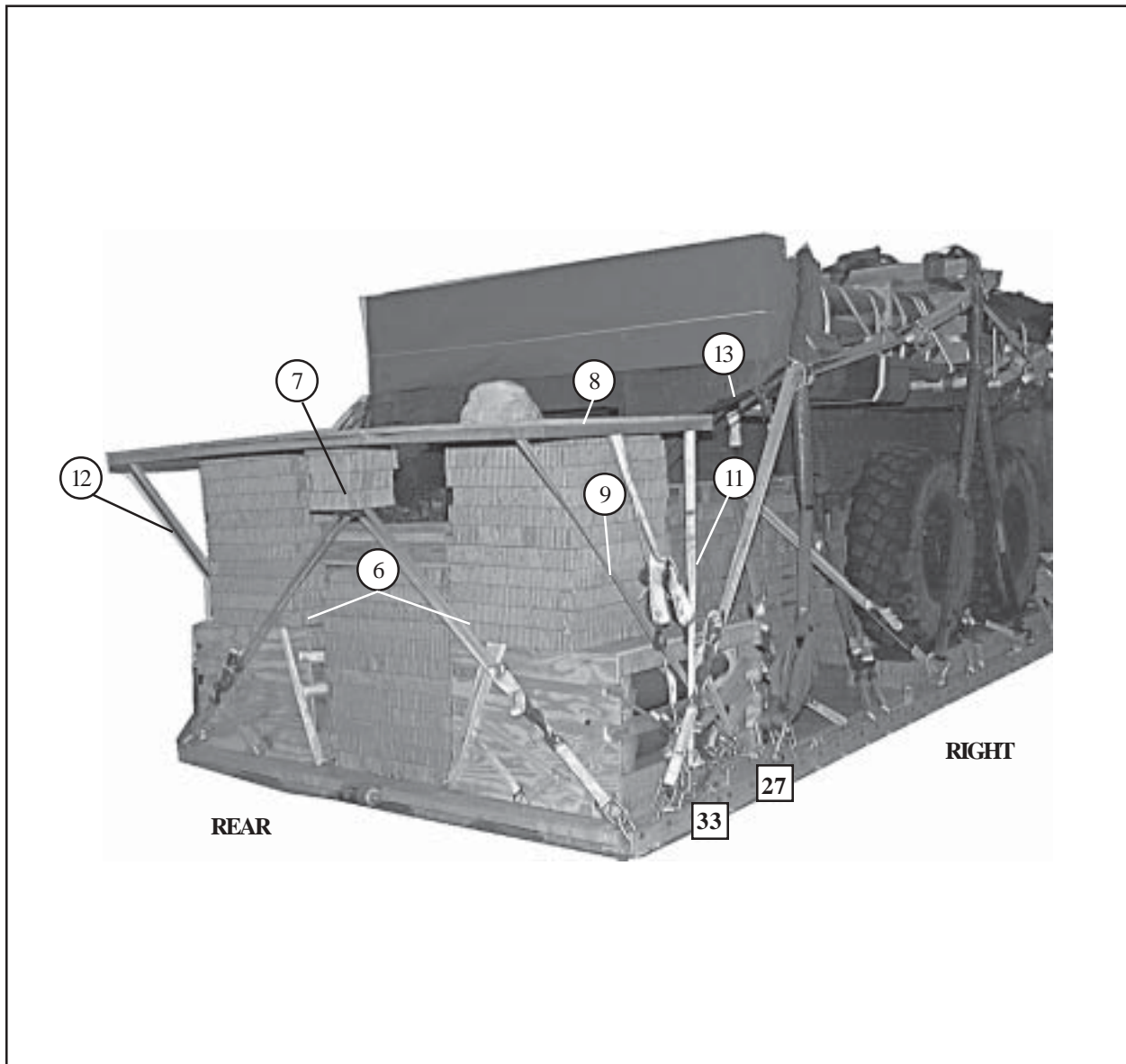

Figure 5-17. Parachute stowage platform positioned



- ⑥ Position the two 24- by 24-inch honeycomb stacks on the inside and rear edges of platform accompanying loads.
- ⑦ Position the 10- by 10-inch honeycomb stack centered on the trailer lunette.
- ⑧ Position the parachute stowage platform against the landing leg gear box. Center it left to right and on top of the 10- by 10-inch honeycomb stack and two 24- by 24-inch honeycomb stacks.
- ⑨ Route a lashing from clevis 33 up through the center right hole in the parachute stowage platform and down through the front right hole and secure with loadbinder.
- ⑩ Route a lashing from clevis 33A through the center left hole in the parachute stowage platform through the front left hole and secure with loadbinder. (Not Shown).
- ⑪ Route a lashing from clevis 27 up through the rear right hole in the parachute stowage platform and down through the center right hole and secure with loadbinder.
- ⑫ Route a lashing from clevis 27A up through the rear left hole in the parachute stowage platform through the center left hole and secure with loadbinder.
- ⑬ Secure a length of 1-inch tubular nylon webbing through the front right hole in the parachute stowage platform and through the trailer front left sling guide. Repeat on the left side.

5-13. Stowing Cargo Parachutes

Stow six G-11C cargo parachutes according to FM 4-20.102/NAVSEA SS400-AB-MMO-010/TO 13C7-1-5 and as shown in *Figure 5-18*.

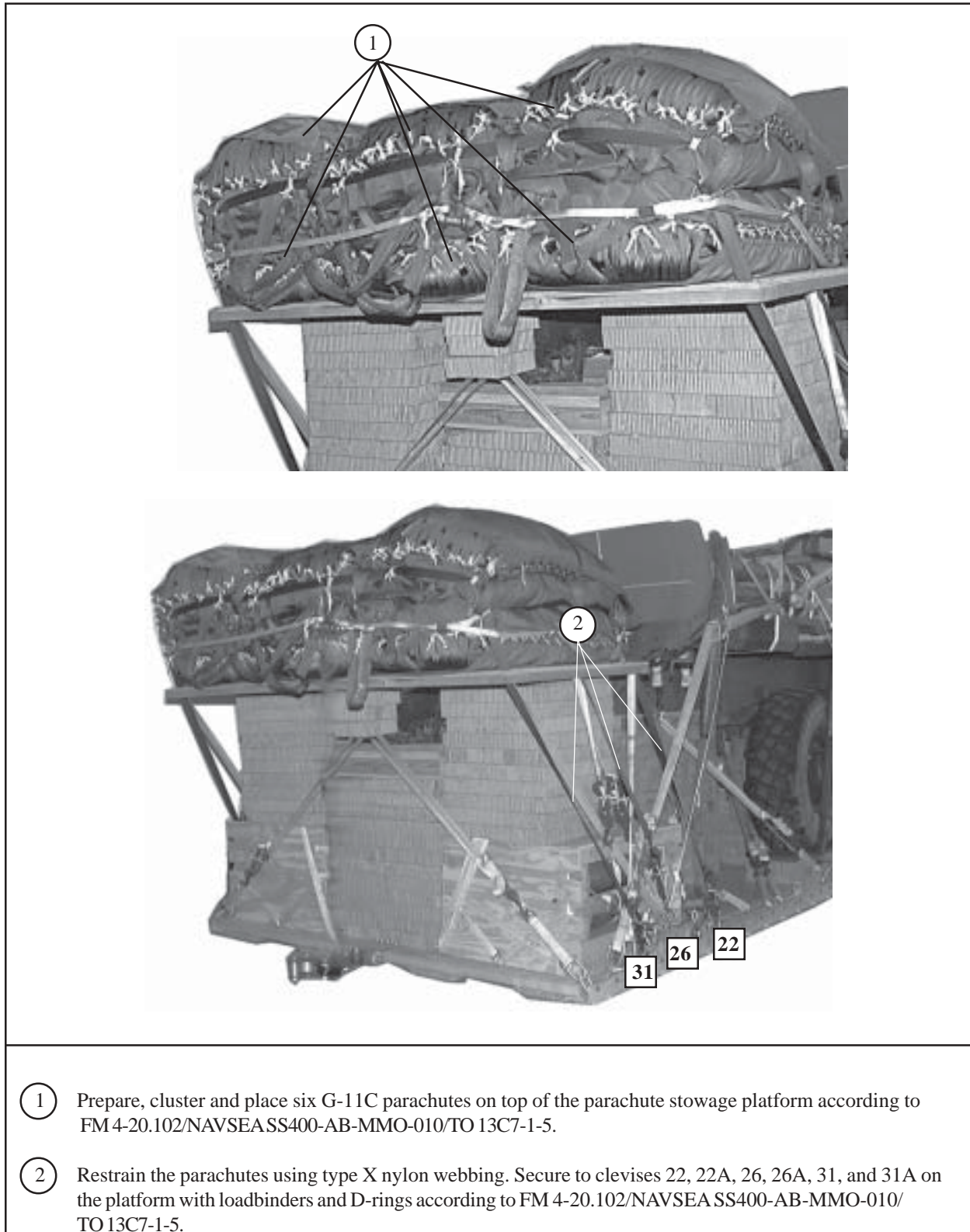
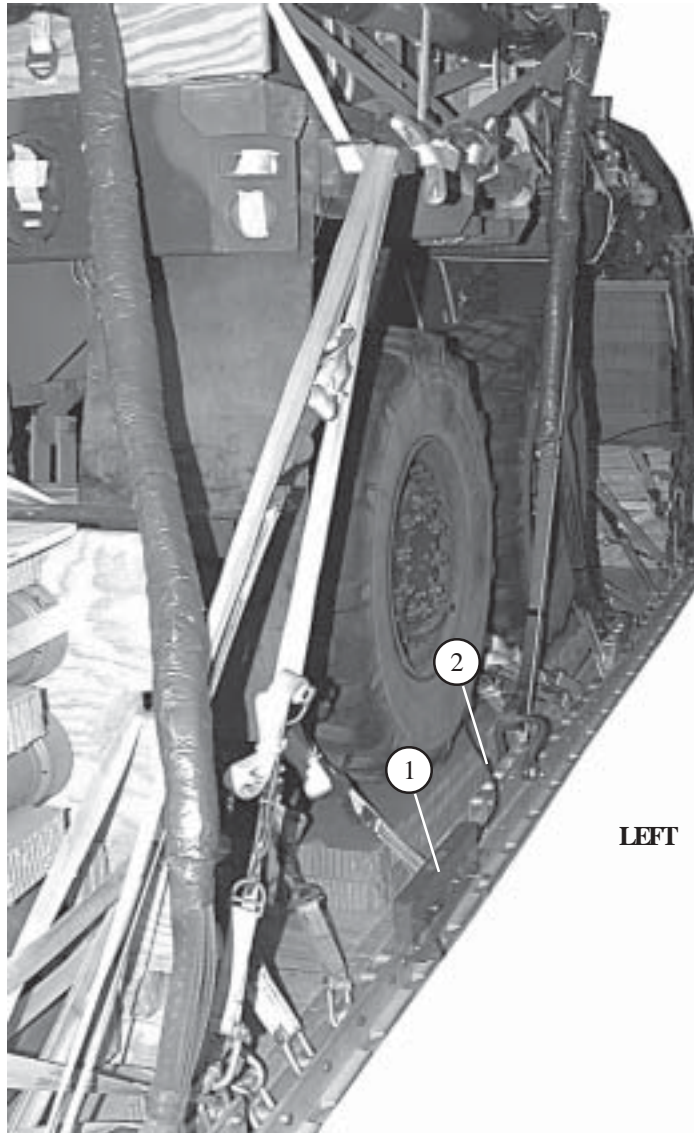

Figure 5-18. Parachutes stowed

5-14. Installing Extraction System

Install the components of the extraction force transfer coupling (EFTC) according to FM 4-20.102/NAVSEA SS400-AB-MMO-010 /TO 13C7-1-5 and as shown in *Figure 5-19*.



- ① Install the EFTC mounting brackets in the rear mounting holes on the left platform rail, according to FM 4-20.102/NAVSEA SS400-AB-MMO-010/TO 13C7-1-5.
- ② Install the EFTC extraction system according to FM 4-20.102/NAVSEA SS400-AB-MMO-010/TO 13C7-1-5. Attach a 24-foot release cable to the actuator mounting brackets. Safety tie it with type I, 1/4-inch cotton webbing.

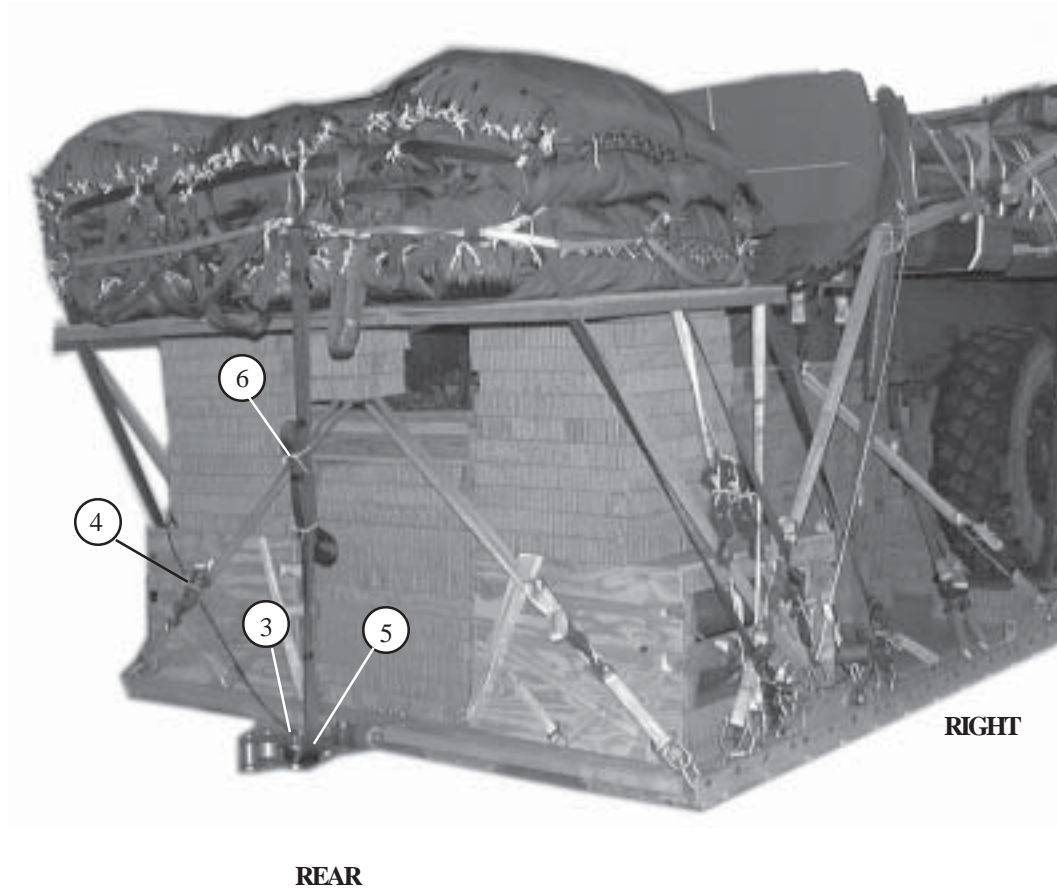

- ③ Install the latch assembly on the extraction bracket according to FM 4-20.102/NAVSEA SS400-AB-MMO-010/TO 13C7-1-5. Attach the release cable to the latch assembly.
- ④ Safety tie the cable with one turn type I, 1/4-inch cotton webbing to the platform bushings or deck rings.
- ⑤ Connect one end of the 9-foot (2-loop), type XXVI nylon sling (deployment line) to the link assembly according to FM 4-20.102/NAVSEA SS400-AB-MMO-010/TO 13C7-1-5. Attach the other end of the sling to the deployment clevises.
- ⑥ Fold the excess deployment line, and secure the folds with type I, 1/4-inch cotton webbing according to FM 4-20.102/NAVSEA SS400-AB-MMO-010/TO 13C7-1-5.

Figure 5-19. Extraction system installed (Continued)

5-15. Installing Release System

Install an M-2 cargo parachute release according to FM 4-20.102/NAVSEA SS400-AB-MMO-010/TO 13C7-1-5 and as shown in *Figure 5-20*.

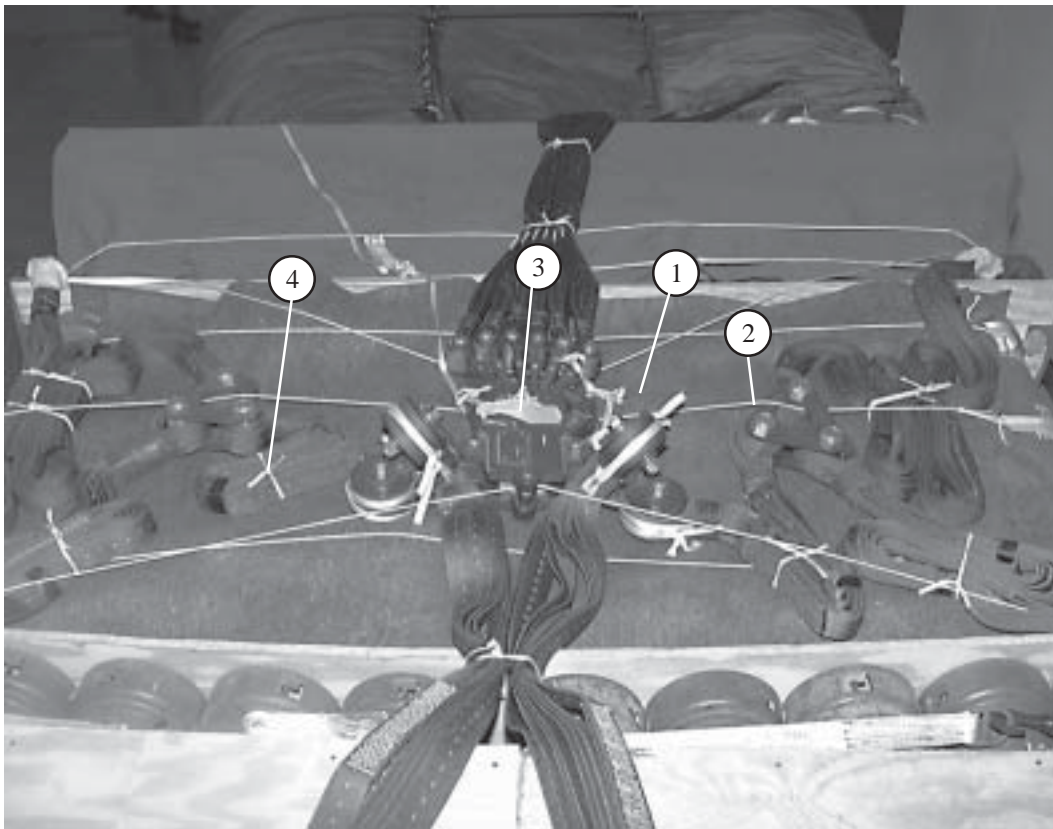

- ① Cover cell #2 with a piece of 9/16-inch felt and secure it with type III nylon cord.
- ② Safety tie the suspensions slings three-point links with a length of type III nylon cord. Secure to convenient points on the load in accordance with FM 4-20.102/NAVSEA SS400-AB-MMO-010/TO 13C7-1-5.
- ③ Place the M-2 release centered on cell #2 and safety tie to convenient points on the load in accordance with FM 4-20.102/NAVSEA SS400-AB-MMO-010/TO 13C7-1-5.
- ④ Fold and safety tie any slack in the suspension slings with single turn of type I, 1/4-inch cotton webbing.

5-16. Installing Provisions for Emergency Restraints

Select and install provisions for emergency restraints according to the emergency restraint requirements table found in FM 4-20.102/NAVSEA SS400-AB-MMO-010/TO 13C7-1-5.

5-18. Marking the Rigged Load

Mark the rigged load according to FM 4-20.102/NAVSEA SS400-AB-MMO-010/TO 13C7-1-5 and as shown in *Figure 5-21*.

5-17. Placing Extraction Parachute

Select the extraction parachute and extraction line needed using the extraction parachute and extraction line requirements table found in FM 4-20.102/NAVSEA SS400-AB-MMO-010/TO 13C7-1-5.

5-19. Equipment Required

Use the equipment listed in *Table 5-2* to rig this load.

CAUTION
Make the final rigger inspection required by
FM 4-20.102/NAVSEA SS400-AB-MMO-010/TO
13C7-1-5 before the load leaves
the rigging site.

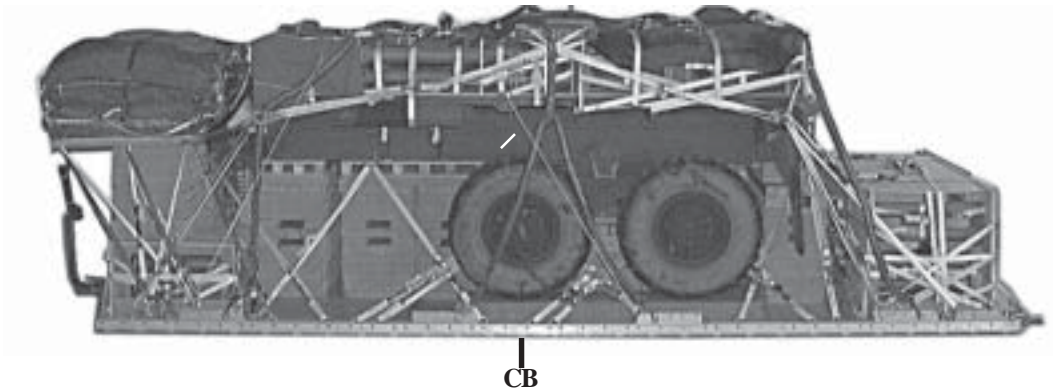

RIGGED LOAD DATA

Weight: Load shown	30,330 pounds
Maximum load allowed	30,900 pounds
Height	99 1/2 inches
Width	108 inches
Overall-Length	306 inches
Overhang:	
Front	0 inches
Rear (EFTC)	18 inches
CB (from front edge of platform)	145 inches
Extraction System	EFTC

Table 5-2. Equipment required for rigging the M1095, 5-ton trailer for low-velocity airdrop on a type V platform

National Stock Number	Item	Quantity
8040-00-273-8713	Adhesive, paste, 1-gal	As required
1670-01-035-6054	Bridle, extraction line bag (for DES)	1
1670-00-434-5796	Clevis assembly, suspension, 1-in., (large)	12
4030-00-090-5354	Cloth, coated, (nylon, type II, 18 oz., green, 60-in.)	As required
8305-00-880-8155	Cord, fibrous, (nylon, type III, 550-lb)	As required
4020-00-240-2146	Coupling, airdrop extraction force transfer, w/24-ft. cable	1
1670-00-360-0328	Cover, clevis, large	As required
8135-00-664-6958	Cushioning material, packaging, (cellulose wadding)	As required
8305-00-958-3685	Felt sheet, 1/2-in. thick	As required
1670-01-183-2678	Leaf, extraction line, bag	1
	Line, extraction line, type XXVI nylon webbing:	
1670-01-064-4452	60-ft (1-loop), drogue, (C-17 aircraft)	1
1670-01-064-4454	60-ft (6-loop), (C-130 and C-5 aircrafts)	1
1670-01-468-9178	140-ft (6-loop), (C-17, C-141 and C-5 aircrafts)	1
1670-01-483-8259	Link, tow release mechanism, (H-block), (C-17 aircraft)	1
	Link assembly:	
	Two-point:	2
5306-00-435-8994	Bolts, 1-in diam, 4-in long	(4)
5310-00-232-5165	Nuts, 1-in	(4)
1670-00-003-1953	Plate, side, 3 3/4-in., arm, cargo extra	(4)
1670-00-003-1954	Plate, side, 5 1/2-in., arm, cargo extra	(4)
5365-00-007-3414	Spacers, large	(4)
1670-00-006-2752	Three-point coupling (42K)	2
1670-01-307-1055	Four-point	1

Table 5-2. Equipment required for rigging the M1095, 5-ton trailer for low-velocity on type V airdrop platform (continued)

National Stock Number	Item	Quantity
5510-00-220-6146 5510-00-220-6148 5510-00-220-6274	Lumber, softwood, 96-in: 2- by 4-in. 2- by 6-in. 4- by 4-in.	As required As required As required
5315-00-010-4659 5315-00-010-4661 5315-00-753-3885	Nail, steel wire, common: 8d 10d 16d	As required As required As required
1670-00-753-3928	Pad, energy-dissipating, (honeycomb) 3- by 36- by 96-in:	55 sheets
1670-01-016-7841	Parachute: Cargo: G-11C	6
1670-00-040-8135	Cargo extraction: 28-ft (HD)	2
1670-01-063-3715	Drogue (for DES), (C-17): 15-ft	1
1670-01-353-8425 1670-01-162-2372 1670-01-162-2376 1670-01-247-2389 1670-01-162-2381	Platform, airdrop, type V, 24-ft: Bracket assembly, coupling Clevis, assembly, type V Extraction bracket assembly Link, suspension bracket, type V Tandem link assembly (Multipurpose link)	1 (1) (80) (1) (8) (2)
5530-00-262-8195 5530-00-128-4981	Plywood, construction, 48- by 96-in: 1/2-in 3/4-in	As required As required
1670-01-097-8817	Release, cargo parachute, M-2	1
1670-01-062-6304	Sling, cargo, airdrop: For deployment line: 9-ft (2-loop), type XXVI nylon webbing	1

Table 5-2. Equipment required for rigging the M1095, 5-ton trailer for low-velocity airdrop on a type V platform (continued)

National Stock Number	Item	Quantity
	For lifting:	
1670-01-062-6305	9-ft (4-loop), type XXVI nylon webbing	2
1670-01-064-4453	20-ft (4-loop), type XXVI nylon webbing	1
	For suspension:	
1670-01-062-6306	3-ft (4-loop), type XXVI nylon webbing	4
1670-01-062-6305	9-ft (4-loop), type XXVI nylon webbing	2
1670-01-062-6310	11-ft (4-loop), type XXVI nylon webbing	2
1670-01-062-6308	16-ft (4-loop), type XXVI nylon webbing	2
1670-01-064-4453	20-ft (4-loop), type XXVI nylon webbing	2
	For riser extension:	
1670-01-062-6311	120-ft (2-loop), type XXVI nylon webbing	6
5340-00-040-8219	Strap, parachute release, multi-cut with 3 knives	2
7510-00-266-5016	Tape, adhesive, 2-in (masking)	As required
7510-00-074-5124	Tape, type IV, cloth-back, adhesive sensitive, 2-in	As required
5340-00-937-0273	Tiedown assembly, 15-ft	122
	Webbing:	
8305-00-268-2411	Cotton, type I, 1/4-in, 80-lb	As required
8305-00-082-5752	Nylon, tubular, 1/2-in, 1,000-lb natural	As required
8305-00-263-3591	Type VIII, natural	As required
8305-00-261-8584	Type X, natural	As required

Appendix A

INSTALLING SUSPENSION SLING SAFETY TIES

Installing the suspension sling safety ties keeps the suspension slings from making contact with the load. The procedures in this Appendix are different from those in *FM 4-20.102/NAVSEA SS400-AB-MMO-010/TO 13C7-1-5*. An exception to *FM 4-20.102/NAVSEA SS400-AB-MMO-010/TO 13C7-1-5* is granted. The procedures in this Appendix must be followed. Safety tie the front and rear suspension slings according to instructions shown below.

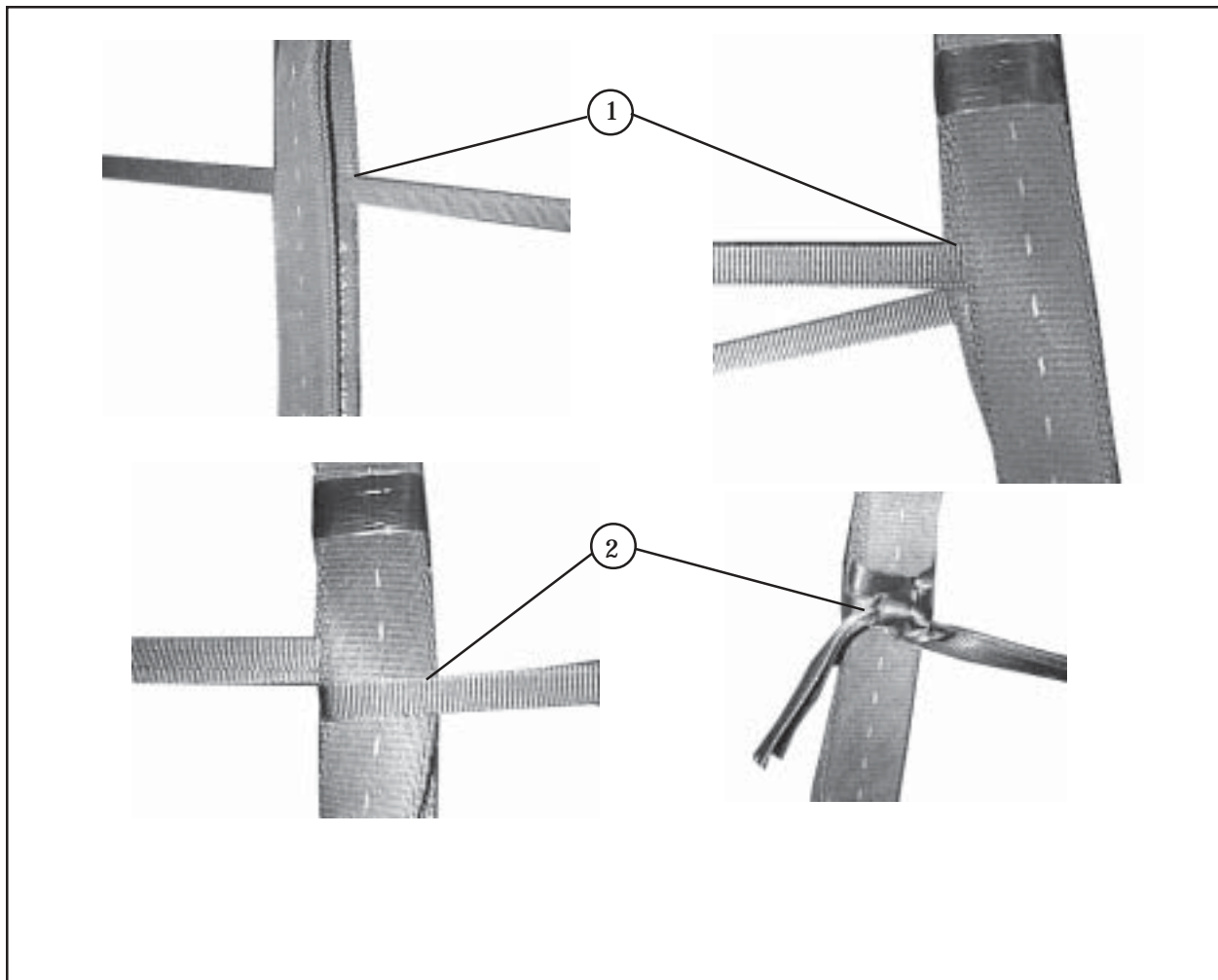

- ① Cut two lengths of 1/2-inch tubular nylon webbing, making each long enough to reach from the left front suspension sling to the right front suspension sling plus 8 feet. Split the plies of the left front suspension sling. Route two lengths of the 1/2-inch tubular webbing through the plies of the sling from inboard to outboard about 3 feet.
- ② Route the 3 foot running end from outboard to inboard around the inside plies and around the outboard plies from inboard to outboard. Tie it in place on the inboard side with three alternating half-hitches with an overhand knot in the running end.

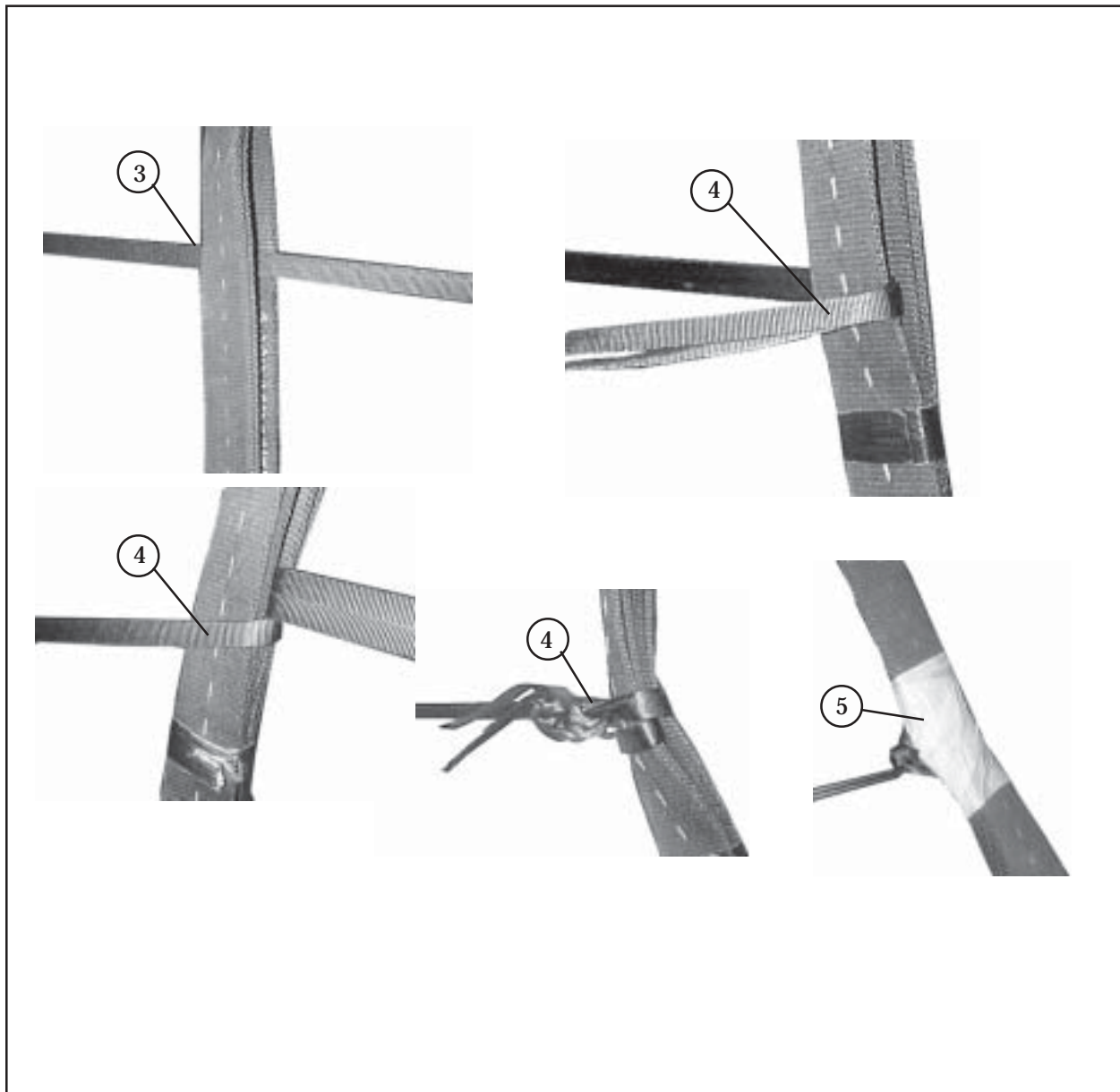

- ③ Split the plies of the right front suspension sling and route the running ends of the two lengths of 1/2-inch tubular nylon webbing through the plies of the sling from inboard to outboard. Pass enough of the webbing through the sling to take the slack out, but not enough to keep the slings from hanging in their natural position.
- ④ Route the running end from outboard to inboard around the inside plies and around the outboard plies from inboard to outboard. Tie it in place on the inboard side with three alternating half-hitches with an overhand knot in the running end.
- ⑤ Tape the webbing to the slings with masking tape.
- ⑥ Repeat steps 1 through 5 on the rear suspension slings. (not shown)
- ⑦ When using four-loop, type XXVI suspension slings, wrap each four plies with a 10- by 10-inch piece of cotton muslin. Secure each wrap with one single turn of 1/4-inch cotton webbing. (Not shown)

REFERENCES

- AFR 55-40/AR 59-4 Joint Airdrop Inspection Records, Malfunction Investigations and Activity Reporting. 1 May 1998.
- *AFMAN(I) 24-204/TM 38-250/
NAVSUP PUB 505/MCOP 4030 Preparing Hazardous Materials for Military Air Shipments.
December 2001.
- **FM 4-20.102/
NAVSEA SS400-AB-MMO-010/
TO 13C7-1-5 Airdrop of Supplies and Equipment: Rigging Airdrop Platforms.
22 August 2001.
- FM 10-500-53/MCRP 4-3.8/
TO 13C7-18-41 Airdrop of Supplies and Equipment: Rigging Ammunition.
19 August 1996.
- TM 9-2320-365-20/
TO 36A12-1C-1091-1 Operator's Instructions M1078 Series, 2 1/2-Ton, 4x4, Light Medium
Tactical Vehicles (LMTV). September 1998.
- TM 9-2320-365-24P/
TO 36A12-1B-1095-24 Unit, Direct Support, and General Support Maintenance Repair Parts
and Special Tools List for M1078 Series, 2 1/2-Ton, 4x4, Light Medium
Tactical Vehicles (LMTV). 31 July 2001.
- TM 9-2320-366-10-1/
TO 36A12-1C-1091-1 Technical Manual, Operator's Instructions M1083 Series, 5-Ton, 6x6,
Medium Tactical Vehicles (MTV), Volume No. 1 of 2.
15 September 1998.
- TM 9-2320-366-10-2/
TO 36A12-1C-1091-2 Technical Manual, Operator's Instructions M1083 Series, 5-Ton, 6x6,
Medium Tactical Vehicles (MTV), Volume No. 2 of 2.
15 September 1998.
- TM 9-2320-366-10-HR
TO 36A12-1C-1101 Hand Receipt Covering Contents of Components of End Item (COEI),
Basic Issue Items (BII), and Additional Authorization List (AAL) for
M1083 Series, 5-Ton , 6X6, Medium Tactical Vehicles (MTV).
31 May 2001.
- TM 9-2320-366-20-1/TO
36A12-1C-1102-4 Technical Manual, Maintenance Instructions, Unit Maintenance,
M1083 Series, 5-Ton, 6 X 6, Medium Tactical Vehicles (MTV)
Volume No. 1 of 5. 15 September 1998.
- TM 9-2320-366-20-2/TO
36A12-1C-1102-4 Technical Manual, Maintenance Instructions, Unit Maintenance,
M1083 Series, 5-Ton, 6 X 6, Medium Tactical Vehicles (MTV)
Volume No. 2 of 5. 15 September 1998.
- TM 9-2320-366-20-3/TO
36A12-1C-1102-4 Technical Manual, Maintenance Instructions, Unit Maintenance,
M1083 Series, 5-Ton, 6 X 6, Medium Tactical Vehicles (MTV)
Volume No. 3 of 5. 15 September 1998.
- TM 9-2320-366-20-4/TO
36A12-1C-1102-4 Technical Manual, Maintenance Instructions, Unit Maintenance,
M1083 Series, 5-Ton, 6 X 6, Medium Tactical Vehicles (MTV)
Volume No. 4 of 5. 15 September 1998.

TM 9-2320-366-24P-1/TO 36A12-1C-1156-1	Unit, Direct Support, and General Support Maintenance, Repair Parts and Special Tools List for M1083 Series, 5-Ton, 6X6, Medium Tactical Vehicles (MTV) Volume No. 1 of 2. 31 July 2001.
TM 9-2320-366-24P-2/TO 36A12-1C-1156-2	Unit, Direct Support, and General Support Maintenance, Repair Parts and Special Tools List for M1083 Series, 5-Ton, 6X6, Medium Tactical Vehicles (MTV) Volume No. 2 of 2. 31 July 2001.
TM 9-2320-366-34P-1/TO 36A12-1C-1192-1	Technical Manual, Maintenance Instructions, Direct Support, and General Support Maintenance M1083 Series, 5-Ton, 6 X 6, Medium Tactical Vehicles (MTV) Volume No. 1 of 5. 15 September 1998.
TM 9-2320-366-34P-2/TO 36A12-1C-1192-2	Technical Manual, Maintenance Instructions, Direct Support, and General Support Maintenance M1083 Series, 5-Ton, 6 X 6, Medium Tactical Vehicles (MTV) Volume No. 2 of 5. 15 September 1998.
TM 9-2320-366-34P-3/TO 36A12-1C-1192-3	Technical Manual, Maintenance Instructions, Direct Support, and General Support Maintenance M1083 Series, 5-Ton, 6 X 6, Medium Tactical Vehicles (MTV) Volume No. 3 of 5. 15 September 1998.
TM 9-2320-366-34P-4/TO 36A12-1C-1192-4	Technical Manual, Maintenance Instructions, Direct Support, and General Support Maintenance M1083 Series, 5-Ton, 6 X 6, Medium Tactical Vehicles (MTV) Volume No. 4 of 5. 15 September 1998.
TM 9-2330-394-13&P/ TO 36A12-1C-1091-2	Operator's, Unit, Direct Support (DS) Maintenance Manual with Repair Parts and Special Tools List: M1082 Series, 2 1/2-Ton, 4x4, Light and 5-Ton, 6x6, Medium (LMTV/MTV) Trailers.
TM 10-1670-268-20&P/TO 13C7-52-22	Organizational Maintenance Manual (Including Repair Parts and Special Tools List) For The Type V Airdrop Platform and The Dual Row Airdrop Platform. 15 September 2002.
TM 10-1670-277-23&P/TO 13C5-28-2/NAVAIR 13-1-30	Unit and Direct Support (DS) Maintenance Manual (Including Repair Parts and Special Tools List for Parachute, Cargo Type 28-Foot Diameter, Cargo Extraction Parachute Assembly (NSN 1670-00-040-8135). 30 April 2002.
TM 10-1670-278-23&P/TO 13C5-25-2/NAVAIR 13-1-27	Unit and Direct Support (DS) Maintenance Manual (Including Repair Parts and Special Tools List for Parachute, Cargo Type 15-Foot Diameter, Cargo Extraction Parachute. 6 November 1989.
TM 10-1670-280-23&P/TO 13C5-31-2/NAVAIR 13-1-31	Unit and Intermediate Direct Support (DS) Maintenance Manual (Including Repair Parts and Special Tools List) for Parachute, Cargo Type: 100-Foot Diameter, Model G-11B, G-11C, and G-11D (NSN 1670-01-016-7841). 15 September 2002.
TM 10-1670-286-20/TO 13C5-2-41	Unit Maintenance Manual for Sling /Extraction Line Panel (Including Stowing Procedures). 15 March 2001.
TM 10-1670-296-20&P/TO 13C7-49-2	Unit Maintenance Manual Including Repair Parts and Special Tools List for Ancillary Equipment for Low-Velocity Airdrop Systems (LVADS). 15 September 1995.
AFTO Form 22	Technical Order Publication Improvement Report.
DA Form 2028	Recommended Changes to Publications and Blank Forms. February 1974.

Reference-2

***Shipper's Declaration
for Dangerous Goods. Locally Procured Form.

*AFMAN(I) 24-204/TM 38-250 has superseded AFJMAN 24-204/TM 38-250 (15 January 1988).

**FM 4-20.102/NAVSEA SS400-ABMMO-010/TO 13C7-1-5 Has superseded FM 10-500-2/TO 13C7-1-5
(November 1990). This revision reflects this change.

***Shipper's Declaration for Goods has superseded superseded DD Form 1387-2 (February 1982). This revision
reflects this change.

GLOSSARY

AD	airdrop
AFB	Air Force base
AFMAN(I)	Air Force joint manual
AFR	Air Force regulation
AFTO	Air Force technical order
ATTN	attention
BII	Basic Issue Items
CB	center of balance
d	penny
DA	Department of the Army
DC	District of Columbia
DD	Department of Defense
DES	Drogue Extraction System
DTI	Dump Truck Improved
diam	diameter
EFTC	extraction force transfer coupling
FM	field manual
FMTV	family of medium tactical vehicles

ft	foot/feet
gal	gallon
HE	high explosive
HQ	headquarters
in	inch
lb	pound
LMTV	Light medium tactical vehicles
mm	millimeter
No	number
NSN	national stock number
oz	ounce
psi	pounds per square inch
Qty	quantity
TM	technical manual
TO	technical order
TRADOC	United States Army Training and Doctrine Command
US	United States
USAR	United States Army Reserve
VA	Virginia
WP	White Phosphorus
yd	yard

FM 10-500-71/TO 13C7-6-141
1 DECEMBER 1999

By Order of the Secretary of the Army:

Official:



JOEL B. HUDSON

*Administrative Assistant to the
Secretary of the Army*
0000503

ERIC K. SHINSEKI
*General, United States Army
Chief of Staff*

DISTRIBUTION:

Active Army, Army National Guard, and U.S. Army Reserve: To be distributed in accordance with the initial distribution number 115485, requirements for FM 10-500-71.

PIN: 075371-002